

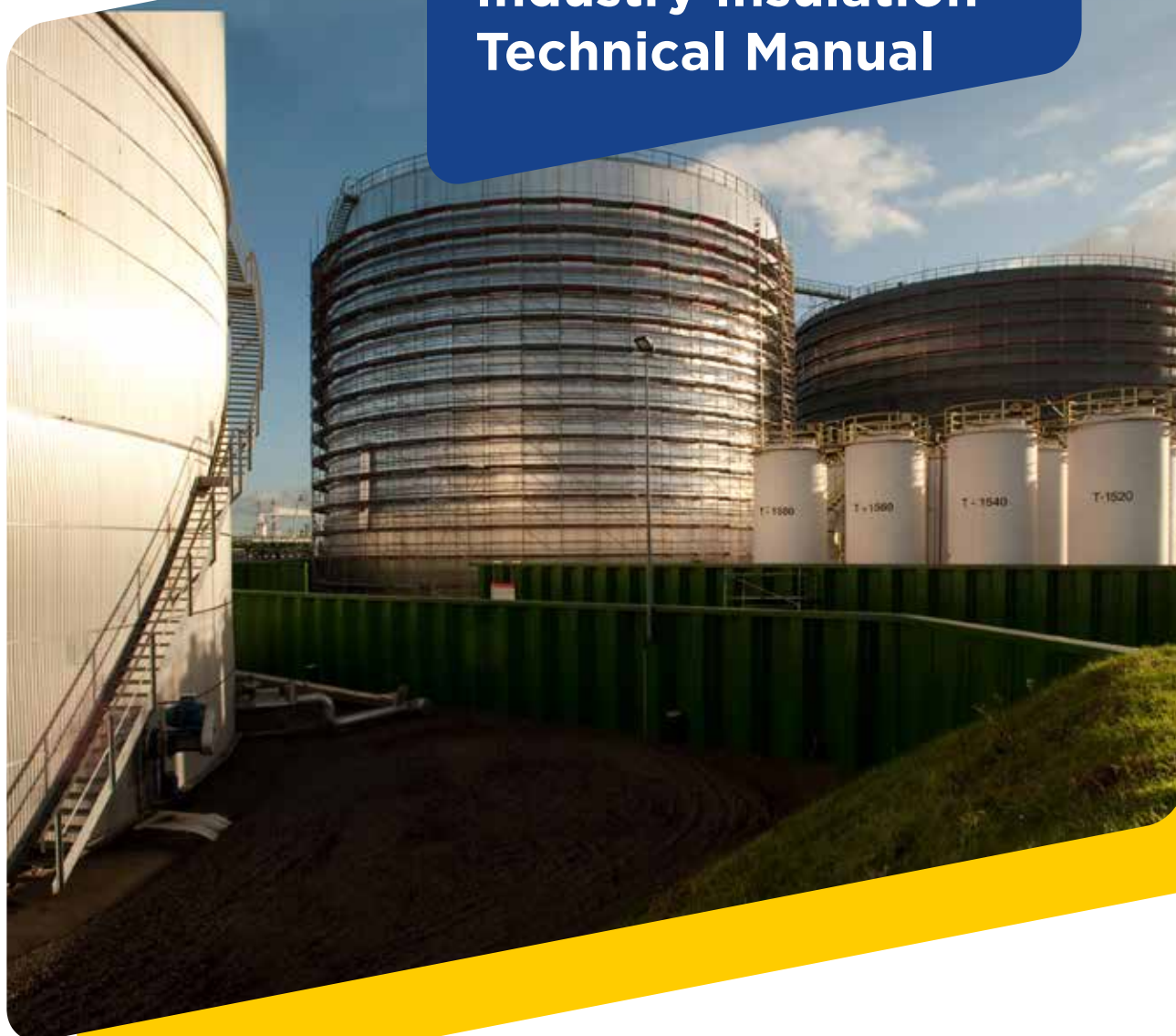

# ISOVER Industry Insulation Technical Manual





# ISOVER Industry Insulation

<b>1. Introduction.....</b>	<b>6</b>
<b>1. Insulation in industry .....</b>	<b>10</b>
<b>1.1 Range of applications.....</b>	<b>10</b>
1.2 Reasons to insulate.....	12
1.3 Energy efficiency.....	14
1.4 Acoustic performance .....	17
1.5 Giving fire no chance .....	18
1.6 Corrosion protection.....	19
1.7 Environmental protection.....	20
<b>2 ISOVER TECH Range.....</b>	<b>22</b>
2.1 ISOVER TECH European product range - For improved energy efficiency in industry.	22
2.2 The right solutions for all temperatures .....	23
<b>3. Materials .....</b>	<b>24</b>
3.1 Glass wool .....	24
3.2 Stone wool .....	26
3.3 ULTIMATE .....	28
<b>4. Environment, health &amp; safety .....</b>	<b>30</b>
4.1 Saint-Gobain's EHS policy.....	30
4.2 Protection of the environment .....	30
4.3 EUCEB certification .....	32
4.4 Safe Use Instruction Sheet (SUIS) .....	32
4.5 Environmental Product Declaration (EPD).....	33
<b>5. Standards for industry applications .....</b>	<b>34</b>
5.1. Standardization bodies .....	34
5.2. Other technical specifications, guidelines .....	35
5.3. Relevant properties for an insulation product .....	36
5.4. List of applicable standards and reference documents .....	36
5.4.1. Harmonized standard.....	36
5.4.2. International standards. Test methods.....	36
5.4.3. European standards:.....	36
5.4.4. ASTM .....	37
5.4.5. Other standards .....	39
<b>2. Theory of Thermal Insulation..</b>	<b>40</b>
<b>1. Basic concepts.....</b>	<b>42</b>
1.1. Thermodynamics and heat transfer .....	42
1.2. Heat transmission mechanisms.....	42
1.2.1. By conduction.....	43
1.2.2. By convection.....	44
1.2.3. By radiation .....	45
1.3. Surface heat transmission .....	46
1.3.1. Convective part of the surface coefficient, $h_{cv}$ .....	46
1.3.2. Radioactive part of the surface coefficient, $h_r$ .....	49
1.3.3. Approximation for calculating the inner surface coefficient of heat transfer, ( $h_i$ ).....	49
1.3.4. Approximation for calculating the outer surface coefficient of heat transfer, ( $h_e$ ).....	49
1.4. Heat transfer by conduction in steady state .....	50
1.4.1. In flat walls .....	50
1.4.2. In cylinders and spheres.....	59
1.4.3. In rectangular sections.....	69
1.5. Thermal transmittance .....	71
<b>2. Temperature distribution.....</b>	<b>74</b>
2.1. Intermediate temperature .....	74
2.2. Surface temperature.....	76
<b>3. Prevention of surface condensation .....</b>	<b>77</b>
<b>4. Special application.....</b>	<b>78</b>
4.1. Longitudinal temperature change in a pipe .....	78
4.2. Change of temperature and cooling time in accumulators and tanks.....	80
4.3. Calculation of freezing and cooling time of liquids at rest .....	80
4.4. Underground pipes.....	83
<b>5. Thermal bridges.....</b>	<b>84</b>
5.1. Average thermal conductivity .....	84
5.2. Design thermal conductivity.....	84
5.2.1. Correction factor F .....	84
5.2.2. Increments of ( $\Delta$ ) .....	84
<b>6. General rules related to the installation.....</b>	<b>87</b>
6.1. Equivalent lengths.....	87
6.2. Energy losses in supports and suspensions.....	87
<b>3. Energy Efficiency .....</b>	<b>88</b>
<b>1. Current situation.....</b>	<b>90</b>
1.1. Sector-by-sector breakdown of energy consumption in Europe.....	90
<b>2. Applicable standards.....</b>	<b>91</b>
<b>3. Why make savings through insulation? .....</b>	<b>91</b>
<b>4. Potential energy saving through insulation .....</b>	<b>92</b>
<b>5. Steps to follow to achieve energy-saving potential .....</b>	<b>93</b>
5.1. Step 1 Insulate uninsulated or damaged parts .....	93
5.2. Step 2 Assess cost-effective insulation and consider energy-efficient cost.....	93
5.3. Step 3 Involve insulation experts in the initial stages of projects and new builds .....	94

<b>6. Real examples from industry..... 94</b>	
6.1. TIPCHECK Glass wool manufacture..... 95	
6.2. TIPCHECK Stone wool manufacture..... 96	
6.3. TIPCHECK Ceramics industry ..... 97	
6.4. TIPCHECK Automotive industry..... 98	
<b>4. Thermal Insulation Techniques.100</b>	
<b>1 ISOVER TECH range..... 102</b>	
1.1 Insulation solutions for pipework.....102	
1.1.1 Insulation with ISOVER TECH Pipe Sections..... 102	
1.1.2 ISOVER TECH insulation solutions for big diameter pipe..... 103	
1.2 Insulation solutions for storage tanks.....105	
1.2.1 Insulation of tank walls ..... 105	
1.2.2 Insulation of tank roofs and higher temperature surfaces.....106	
1.3 Insulation solutions for boilers, exhaust ducts and stacks ..... 107	
1.4 Insulation solutions for special industry applications.....108	
1.4.1 ISOVER CRYOLENE - Insulation for cryogenic tanks ..... 108	
1.4.2 ISOVER TECH "QN"- Insulation solutions in Nuclear Quality ..... 109	
1.4.3 ISOVER "EX"- insulation solutions for Explosion Risk Areas. 110	
<b>2 Applications and drawings ..... 111</b>	
2.1 Thermal Energy Storage - Salt Tanks - Wired Mats Solution ..... 112	
2.2 Thermal Energy Storage - Salt Tanks - Slabs Solution ..... 114	
2.3 Thermal Energy Storage - Sewage Tanks - Wired Mats / Rolls Solution..... 116	
2.4 Thermal Energy Storage Oil Buffer Storage Tanks - Slabs Solution.. 118	
2.5 Big size Pipes - Superheated Steam Pipe - Wired Mats / PSM Solution..... 120	
2.6 Mid Size Pipes - Mid Temperature District heating - Pipe section and Wired Mats (two layers)..... 122	
2.7 Mid Size Pipes - High Temperature Steam Reformer Pipe - Pipe section and Wired Mats (two layers)..... 124	
2.8 Small Size Pipes - Low Temperature Hot Water Pipe - Pipe section..... 126	
2.9 Valve insulation - Mid Temperature Oil process - Mattresses ..... 128	
2.10 Flange insulation - Mid Temperature Oil process - Mattresses ..... 130	
<b>3 Installation guidelines ..... 132</b>	
3.1 Introduction ..... 132	
3.2 Occupational health, safety and risk prevention ..... 132	
3.3 Preliminary and general observations ..... 132	
3.4 Insulation systems for pipes..... 134	
3.4.1 Straight sections. One layer of insulation Pipe Section Solution Wired Mat Solution Pipe Section Mat Solution..... 134	
3.4.2 Straight sections. Two or more layers of insulation ..... 136	
3.4.3 Curved sections. Insulation of elbows ..... 137	
3.4.4 Flanges and valves ..... 138	
3.4.5 Pipes with tracing systems..... 139	
3.4.6 Other pipe components..... 141	
3.5 Insulation systems for equipment and tanks 143	
3.6 Quality inspection plan ..... 152	
3.6.1 Piping 152	
3.6.2 Equipment..... 153	
3.6.3 Works supervision..... 155	
<b>4 Corrosion Under Insulation (CUI) ..... 156</b>	
4.1 Definitions 156	
4.1.1 Humidity, moisture..... 156	
4.1.2 Absolute and relative humidity..... 156	
4.1.3 Water vapour transmission..... 156	
4.1.4 Condensation and dew point ..... 156	
4.2 Insulation products behaviour..... 157	
4.2.1 Wet insulation performance..... 157	
4.2.2 Water ingress..... 157	
4.3 Corrosion Under Insulation (CUI) ..... 158	
4.3.1 What is CUI?..... 158	
4.3.2 Critical conditions and what to do.... 159	
4.3.3 Protection of the metal ..... 159	
4.3.4 Installation of the insulation system.. 160	
4.3.5 Maintenance..... 160	
<b>5. Industrial Noise Control..... 162</b>	
<b>1. Basic concepts..... 164</b>	
<b>1.1. Acoustics ..... 164</b>	
1.1.1. Concept of sound..... 164	
1.1.2. Physical properties of sound..... 164	
1.1.3. Propagation speed ..... 164	
1.1.3.1. Amplitude..... 164	
1.1.3.2. Frequency ..... 164	
1.1.3.3. Frequency ..... 164	
1.4. Other physical magnitudes..... 165	
1.4.1. Sound intensity..... 165	
1.4.2. Sound power..... 165	
1.4.3. Acoustic impedance..... 165	
1.4.4. Noise level scale ..... 166	
1.4.5. Loudness and masking ..... 167	
1.4.6. Noise ..... 168	
1.4.7. Airborne and structure-borne sound ..... 168	
1.4.8. Transversal and longitudinal waves..... 168	
1.4.9. Weighting scales curve A ..... 168	
1.4.10. Octave band level: third-octave level... 169	
1.4.11. Combination of levels..... 170	
1.4.12. NR valuation curves..... 170	
1.4.13. Reflection, absorption and transmission of sound ..... 172	
1.4.14. Diffraction and refraction. .... 172	
1.4.15. Vibrations ..... 173	
<b>2. Sound propagation ..... 174</b>	
2.1. Types of sound sources..... 174	
2.2. Sound propagation in open spaces..... 174	
2.2.1. Point sources ..... 174	
2.2.2. Line sources..... 176	
2.2.3. Environmental factors ..... 177	
2.2.4. Radiation field of a source ..... 182	

## Table of content

2.3. Sound propagation in enclosures .....186	<b>6. Documentation &amp; Appendix. 260</b>
2.3.1. Direct field and reverberated field .....186	<b>1. Scientific and Technical Data ..... 262</b>
2.3.2. Absorption coefficients.....187	1.1 Definitions of symbols.....262
2.3.3. Reverberation.....188	1.2 Maximum temperature differences between surface and ambient air to prevent condensation (dew point).....263
2.3.4. Acoustic conditioning.....192	1.3 Equivalent length for installation-related "thermal bridges" (ISO 12241).....264
2.3.5. Sound absorbing materials.....194	1.4 Wind speeds.....265
2.3.6. Acoustic properties of mineral wool.....196	1.5 Medium velocities in pipe.....266
2.3.7. Acoustic insulation.....198	1.6 Conversion of power units.....266
<b>3. Noise control.....204</b>	1.7 Conversion of energy units.....267
3.1. Principles of noise control.....204	1.8 Specific CO <sub>2</sub> emissions of various energy sources .....267
3.1.1. Noise control at the source .....205	1.9 Emissivity of insulation systems.....268
3.1.2. Noise control in the propagation path..207	1.10 Average working time at industrial plants.....268
3.1.3. Noise control at the receiver.....207	1.11 Mean calorific power of fuels (VDI 4608-2).....269
3.2. Absorbent treatments .....208	1.12 Conversion of SI-units into Imperial units for thermal parameters.....270
3.3. Noise in ducts .....210	1.13 Water vapour resistance factor for insulation materials (ISO 10456).....270
3.4. Acoustic enclosures.....211	1.14 Water vapour diffusion-equivalent air layer thickness (ISO 10456) .....271
3.5. Acoustic screens .....214	1.15 Average temperatures of countries worldwide.....272
3.6. Silencers.....216	<b>2. ISOVER Industry Solutions - Technical Data Sheets ..... 275</b>
3.6.1. Definitions .....216	<b>TECH Lamella Mat</b>
3.6.2. Types of silencers, selection and general principles .....217	MT 2.0, MT 2.1 Alu2.....276
3.6.3. Absorption silencers .....217	<b>TECH Loose Wool</b>
3.6.4. Reactive silencers .....219	TECH Loose Wool, EX, HT, QN.....280
3.6.5. Discharge or blow-off silencers .....219	<b>TECH Pipe Section</b>
3.6.6. Calculations .....220	MT 4.0, MT 4.1, MT 4.2.....288
3.6.7. Regenerated noise or flow noise .....222	<b>U TECH Pipe Section</b>
3.6.8. Pressure losses.....223	MT 4.0, MT 7.0 G1.....294
3.7. Vibration control.....224	<b>CRYOLENE</b>
3.7.1. Introduction.....224	681 AA & VV, 682 AA & VV, 684 AA & VV .....298
3.7.2. Controlling the natural frequencies...225	<b>TECH Crimped Roll</b>
3.7.4. Insulation of vibrations: transmissibility .....225	1.0 Alu1, 2.0 Alu1 .....304
3.7.5. Types of anti-vibration elements .....227	<b>TECH Roll</b>
3.8. Noise in pipes.....228	2.0 Alu2, 3.0.....308
3.9. Personal protection cabins .....230	<b>U TECH Roll</b>
3.10. Hearing protection.....232	2.0 Alu1/V1/V2, MT 4.0 Alu1/V1/V2 .....312
3.11. Active noise control.....234	<b>TECH Slab</b>
3.11.1. Principles of noise control.....234	2.0 Alu1/V1, 2.1 V1/V2, 3.0, 3.0 G1, MT 2.2 V2, MT 3.0, MT 3.1 Alu2/V1, MT 4.0, MT 4.1 Alu2/V1, MT 5.1, HT 6.1 .....316
3.11.2. What is active noise control?.....235	<b>U TECH Slab</b>
3.11.3. Active noise control systems in ducts .....236	2.0 Alu1/V1/V2/G1, MT 3.0 Alu1/V1/V2, MT 3.1 Alu1/V1/V2, MT 5.0 Alu1/V1/V2, MT 6.0 Alu1/V1/G1.....338
3.11.4. Applications of active noise control systems .....239	<b>TECH Telisol 5.0 QN</b> .....348
<b>4. Comfort, safety and measurements .....240</b>	<b>TECH Wired Mat</b>
4.1. Comfort and safety aspects of industrial noise.....240	MT 3.0 Alu1/X/X-X, MT 3.1 Alu1/X/X-X, MT 4.0 Alu1/X/X-X, MT 4.1 Alu1/X/X-X, MT 4.2 X/X-X, MT 5.0 Alu1/X/X-X, MT 5.1 Alu1/X/X-X, MT 5.2 X/X-X, MT 6.1 X/X-X, HT 6.1.....350
4.2. Acoustic magnitudes for measurements and verification methods.....241	<b>U TECH Wired Mat</b>
4.2.1. Measuring acoustic variables.....241	MT 4.0 Alu1/V1/X/X-X, MT 5.0 Alu1/V1/X/X-X, MT 6.0 Alu1/V1/X/X-X.....370
4.2.2. Verification methods.....244	
<b>5. Examples of noise control ..... 246</b>	
5.1. Absorbent treatments .....246	
5.2. Noise control in pipes .....249	
5.3. Silencers .....252	
5.4. Acoustic barriers.....254	
5.5. Acoustic enclosures.....256	
5.6. Noise control in pipes .....258	

# 1. Introduction





## Introduction ..... 8

### 1. Insulation in industry ..... 10

- 1.1 Range of applications ..... 10
- 1.2 Reasons to insulate ..... 12
- 1.3 Energy efficiency ..... 14
- 1.4 Acoustic performance ..... 17
- 1.5 Giving fire no chance ..... 18
- 1.6 Corrosion protection ..... 19
- 1.7 Environmental protection ..... 20

### 2 ISOVER Tech Range ..... 22

- 2.1 ISOVER TECH European product range -  
For improved energy efficiency in industry ..... 22
- 2.2 The right solutions for all temperatures ..... 23

### 3. Materials ..... 24

- 3.1 Glass wool ..... 24
- 3.2 Stone wool ..... 26
- 3.3 ULTIMATE ..... 28

### 4. Environment, health & safety .... 30

- 4.1 Saint-Gobain's EHS policy ..... 30
- 4.2 Protection of the environment ..... 30
- 4.3 EUCEB certification ..... 32
- 4.4 Safe Use Instruction Sheet (SUIS) ..... 32
- 4.5 Environmental Product Declaration (EPD) ..... 33

### 5. Standards for industry applications ..... 34

- 5.1. Standardization bodies ..... 34
- 5.2. Other technical specifications, guidelines ..... 35
- 5.3. Relevant properties for an insulation product ..... 36
- 5.4. List of applicable standards and reference documents ..... 36
  - 5.4.1. Harmonized standard ..... 36
  - 5.4.2. International standards. Test methods ..... 36
  - 5.4.3. European standards: ..... 36
  - 5.4.4. ASTM ..... 37
  - 5.4.5. Other standards ..... 39

# Introduction

*At ISOVER, we offer insulation solutions for thermal, fire, sound and corrosion protection for any industrial application no matter if in power generation, oil & gas or process industry, from cryogenic tanks to process pipelines and vessels to high-temperature boilers or special equipment.*

*The ongoing rise in energy prices has highlighted an urgent need to reduce energy loss. This has led the insulation industry to focus on developing new and improved structural insulation products. Nevertheless, the potential of energy savings in industry applications is still often underestimated or ignored.*

*At ISOVER, we work closely together with our customers and various stakeholders, so that we perfectly understand the demands and specifics of industry-related insulation projects. Our experts provide you and your customers with a safe, comfortable and sustainable answer at any stage of the project.*

*You will find in this manual the complete overview of energy efficient and sustainable ISOVER solutions in industry, extensive theoretical information about insulation in industry, standards & regulations, technical documents, energy audit schemes, as well as application and installation guidelines for ISOVER mineral wool solutions.*

*Beyond conventional applications, complex insulation scenarios are addressed, focusing on the most sustainable and energy-efficient insulation solutions.*

*Our aim is to provide a technical reference document for developers, planners, engineers and contractors.*

*Furthermore, this manual will be a valuable source of information for students, mentors, academic supervisors, or any other stakeholders involved with insulation in industry.*

This manual is not strictly limited to commercial use but is also for educational and informational purposes.

**For end-users and plant operators:**

ISOVER TECH insulation solutions are sustainably fulfilling your demands for process safety and personal protection but also help you to cut costs by reducing heat loss and CO<sub>2</sub> emissions improving the plant's energy efficiency.

**For planners and designers:**

With our long-term competence, services and tools together with an industry-adapted and certified product portfolio, we help you to plan and optimise the design of insulation systems in terms of costs and efficiency.

**For installers and contractors:**

We provide you with high-performing, cost-efficient and easy-to-use insulation solutions that you can trust in – no matter if for quick maintenance, demanding turnaround or new projects locally or with international scope.

**For technical insulation distributors:**

ISOVER TECH insulation solutions satisfy the high-quality demands of your customers and are optimised to reduce transport and storage space, costs and energy to improve service time and reduce capital costs.



# 1 Insulation in industry

## 1.1 Range of applications

The insulation of industrial process plants and equipments places high demands on the system designer, installer and the insulation supplier.

**ISOVER has worked closely with industrial process designers, operators and contractors to develop a range of industry solutions that meet any insulation requirement on tanks, vessels, pipes and other process equipments in power generation, oil & gas, chemical and other processing industries:**

- **Providing a choice of products that meet demands for flexibility and ease of installation,**
- **Capable of coping with the daily stresses of expansion and contraction, vibration and fluctuating temperature.**



### Pipework

Pipework systems designed to transport liquids and gases are an integral part of any industrial process. Pipe insulation is essential to ensure process and media stability, reduce heat loss and energy costs, provide personnel and corrosion protection.

ISOVER TECH pipe solutions are the perfect choice to address all of these requirements – providing thermal, sound insulation and fire protection within a single product. They are ideal for a full scope of temperature ranges, from small to big pipe sizes.



### Storage tanks

Storage tanks in industry are as variable in size, shape and media temperature as the processes they support. However, they all need effective insulation that meets the requirements in terms of maintaining temperature stability, preserving heat and cold, and satisfying all safety requirements, such as protecting personnel from hot or cold surfaces.

ISOVER therefore offers a wide choice of efficient and flexible TECH solutions for the insulation of tank walls and roofs, requiring support structures or not.



### Boilers, heaters and vessels

Boilers, heaters, vessels and industrial ovens place very high demands on insulation systems operating at high temperatures. While personnel protection is usually considered in thermal specifications, economic and sustainable design to improve efficiency, reducing energy consumption and CO<sub>2</sub> emissions often still needs to be adopted.

ISOVER supplies flexible, light and efficient TECH range products that are usable up to 700 °C, optimising heat loss with less thickness needs when there are space constraints.



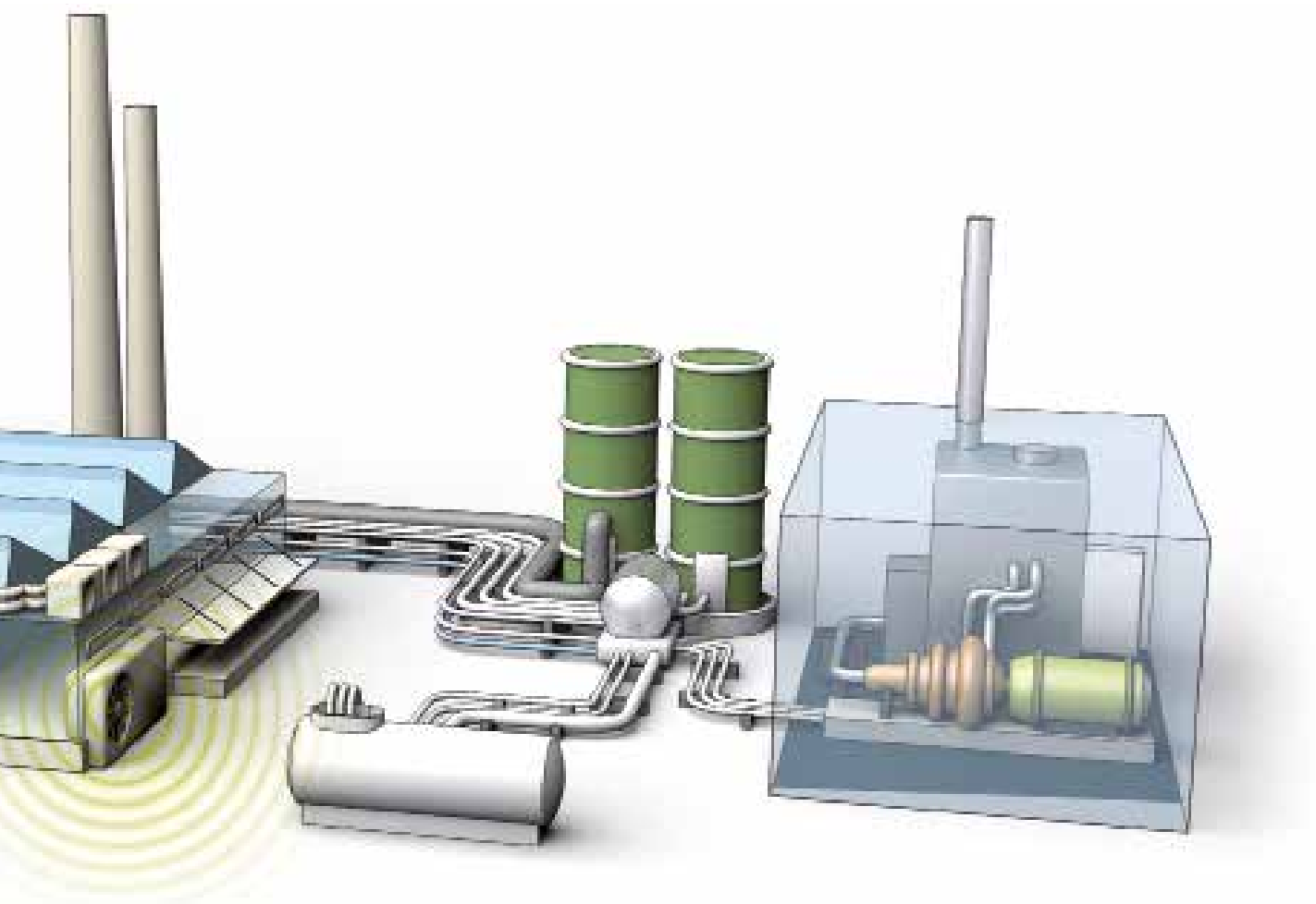

Exhaust ducts and stacks

Insulation of flue gas or exhaust duct systems is vital to a plant's energy and process flow management. Thermal insulation is key to reducing heat loss and protecting personnel. Even more important is the control of the flue gas temperature to prevent condensation and corrosion. High flow speeds, pressures and turbulence are a prime cause of noise, requiring efficient sound insulation.

ISOVER's flexible and space saving TECH range provides an all-in-one solution, offering a range of different performance and temperature levels for rectangular and circular or uneven structures.

Process equipment

In addition to the main industrial process components there are many other elements of process equipment that are particularly challenging in terms of thermal and acoustic insulation as well as from an installation point of view.

Heat exchangers, small vessels and turbines are just some examples of the areas for which the ISOVER TECH range is able to provide standard, flexible and multi-purpose insulation products, as well as customized solutions to meet individual customer needs.

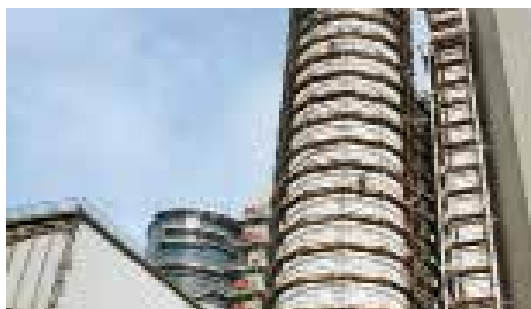

## 1.2 Reasons to insulate

**Insulation is required for safety and security, to reduce heat loss and to increase the sustainability of processes. ISOVER offers the right solutions for all these requirements. There are a number of key reasons for insulating industry equipment and processes:**



### Personnel protection

- To protect personnel from contact injuries and skin burns when working close to hot pipe and equipment surfaces, e.g. maximum surface temperature requiring 60°C or 35°K above ambient.

### Process security

- To maintain temperature limits in industrial processes for transported or stored liquid or gaseous media.
- To prevent corrosion due to high humidity levels or temperatures below the dew point.
- To prevent pipework and equipment from freezing in low ambient temperatures.

### Reduction of heat loss costs

- To reduce heat loss or gain and therefore reduce the amount of energy needed to maintain process equilibrium and save cost (heat loss costs can be easily calculated on the basis of ISO 12241 and industry standards such as VDI 2055 with ISOVER thermal calculation software TechCalc 2.0).
- Optimizing the initial insulation will reduce installation costs and provide maximum energy savings throughout the lifetime of the installation.

### Reduction of environmental impacts

- Optimising the insulation efficiency will maximise the potential for CO<sub>2</sub>-saving (and reduce costs for CO<sub>2</sub> emission certificates), as well as providing a buffer against future rising energy costs.
- Using innovative insulation materials, such as ULTIMATE, and new insulation systems, such as low emissivity cladding systems, will help to maximise potential energy savings and improve environmental protection on industrial equipment.

### Improved sustainability through maximum thermal performance

- The ISOVER TECH product range is designed to give optimum thermal conductivity for each application and temperature. The thermal conductivity of the insulation is measured over the full temperature scale in accordance with EN 12667 for flat products and ISO EN 8497 for pipe sections.
- The thermal performance of ISOVER products is guaranteed by tight quality control, both internally and externally, for instance through the VDI 2055 quality scheme or other third party accreditations. Since 2013, all ISOVER technical insulation products in Europe are CE marked according to the EN 14303 standard for mineral wool insulation.





### 1.3 Energy efficiency

#### Industry insulation untapped potential

ISOVER identified together with EiiF and the Ecofys study a tremendous energy savings potential of industry insulation in Europe of more than 620 PJ. As a consequence, 15 coal-fired power plants of 500 MW could be switched off, if uninsulated areas were insulated and insufficient or damaged insulation were replaced.

Industrial insulation is a Best Available Technique, which could help EU28's industry to reduce its total energy consumption by 4 %. And usually the payback of the insulation investment is less than 2 years, sometimes even less than 1 year.

All this is stated in the Ecofys Study: "Climate protection with rapid payback" initiated by the European Industrial Insulation Foundation (EiiF), of which ISOVER is a founding member.



#### Where does the huge insulation potential come from?

Thermal insulation specifications follow today often only personal protection (minimum hot surface temperature) requirements or outdated static heat loss restrictions. Compared to building regulations, insulation thicknesses in industry are equal or lower while temperature differences are unequally higher.

Huge potential also exists in current industry plants and maintenance. Parts of the equipment are uninsulated, damaged and not replaced. Insulation thickness tables are outdated, still following energy price levels of the last decades.



#### How can insulation design be changed?

Insulation is still seen as a cost rather than an investment. And often the current practice is not even at a today's cost-effective optimum not to mention a sustainable, energy-efficient level.

By applying standards like ISO 12241 and VDI 2055 economic insulation thicknesses can easily be calculated. If today's costs are shifted from higher heat loss costs to higher insulation investment/maintenance costs, 75 % of the total insulation potential can already be seized without additional efforts.

Total costs of insulation depending on heat loss costs versus costs for improved insulation

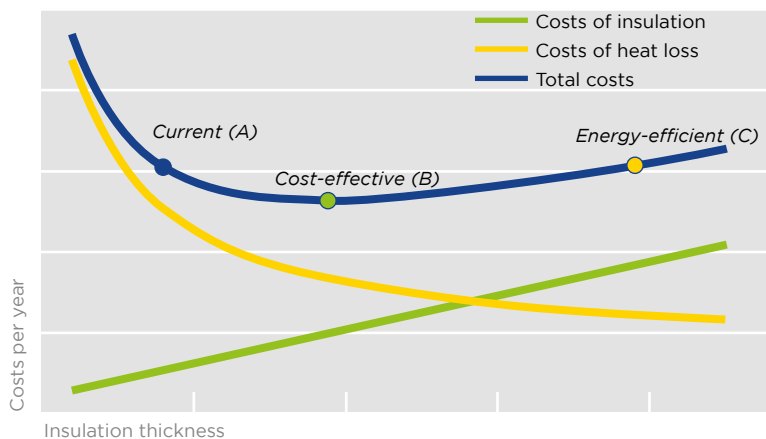

## ISOVER tools and services

### How can ISOVER help you to identify the insulation potentials?

ISOVER has long-term proven expertise in industrial insulation and provides thermal audits, calculation tools and high-performing innovative products to seize the enormous saving potentials



### ISOVER – thermal audits in industry plants

ISOVER has certified engineers able to perform Thermal Insulation Performance Checks (TIPCHECK), using thermography and calculations to identify saving potentials in industrial plants following the EiiF Standard.

Together with the customer, we identify an action and priority plan and can calculate not only energy savings but also payback and amortisation times.

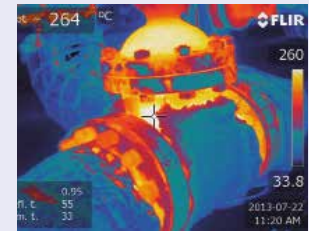

### ISOVER TechCalc 2.0 – Thermal calculations mobile, fast and more advanced



The professional tool for all thermal calculations in technical insulation – now also mobile, faster and even more advanced!

Calculating heat loss, surface temperature,

required insulation thickness, economic insulation design has never been easier.

TechCalc 2.0 with a new interface guides you in 5 easy steps towards clear, precise and standard-conforming results.

It works with open databases to give you full flexibility in using different insulation materials and products, but always according to the principles of ISO 12241, ISO 23993, VDI 2055 standards and guidelines.

Available already in 8 languages and 10 country versions with locally adapted data, it is the perfect tool for planners, designers, contractors and all persons involved in thermal insulation design.

For more information and a 30-day free licence, please visit [www.ISOVER-technical-insulation.com](http://www.ISOVER-technical-insulation.com)

### ISOVER EcoTech – Optimising Total Cost of Ownership (TCO) design



**With ISOVER EcoTech our industry insulation experts are able to build a customer's plant according to energy efficient insulation design.**

By using plant-specific input, different insulation designs can be compared, optimising the total cost of ownership, showing financial payback and amortisation times.

ISOVER EcoTech helps planners, designers and contractors to upgrade insulation design to reach cost-efficient and sustainable insulation standards by reducing heat loss, showing clear financial benefits.



**U TECH high performance in higher temperatures**



**ULTIMATE**, the latest innovation in mineral wool from ISOVER, provides unique advantages from medium to higher temperatures up to 700 °C - especially when the energy efficiency of insulation design needs to be increased, with insulation space and weight restrictions.

**ULTIMATE provides:**

- **Up to 35 % increase in thermal performance**
- **Up to 30 % savings in required insulation thickness**
- **Up to 50 % savings in insulation weight** compared to traditional stone wool insulation design.

Without shot in the product, ULTIMATE's elastic, long and light fibres can be compressed and once installed keep the insulation properties and thickness over time - even when exposed to vibrations, thermal shocks and other industry-typical conditions.

By perfectly combining the advantages of glass- and stone wool in one product, ULTIMATE meets the need for higher energy efficiency by maintaining proven insulation practices.

ULTIMATE has now been used for **more than 15 years** in numerous reference projects in power generation, oil & gas, as well as process industry applications.



## 1.4 Acoustic performance

### Silence is golden

**Many industrial installations work at high pressure, with fast-moving media and often turbulence, all of which can cause high noise levels.**

Acoustic insulation in this field therefore has two main objectives:

- To protect the hearing of personnel working close by
- To reduce ambient sound in the local environment particularly in urban areas.

ISOVER offers a wide range of mineral wool solutions for optimal acoustic insulation.

ISOVER mineral wool solutions are characterised by high longitudinal air-flow resistance (up to  $>100 \text{ kPa}\cdot\text{s}/\text{m}$ ) and uniform porosity (93–99%), resulting in high sound attenuation levels.

Their outstanding performance is a direct result of their elastic properties and low modulus of elasticity, which gives ISOVER mineral wool solutions a low dynamic toughness, and makes them superior to other insulants, such as plastic foams.



### Sound absorption

ISOVER mineral wool products offer excellent acoustic absorption, absorbing up to 95 % of sound energy at certain frequencies.

The sound absorption or attenuation properties of ISOVER products (characterised by an absorption coefficient  $\alpha$ ) are listed in relevant technical datasheets.

With ULTIMATE, these high  $\alpha$  values can be achieved at up to 50 % less insulation weight than with traditional stone wool constructions, especially at higher temperatures, as found for instance in exhaust gas and desulphurisation equipment. Special facings, such as black glass tissue or glass fabric, are also available on request for applications requiring even higher acoustic absorption and mechanical stability demands.

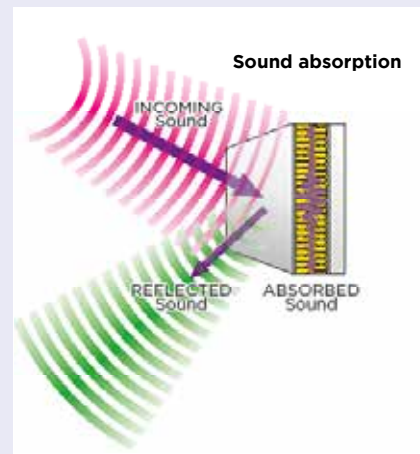

### Sound insulation

In noisy working areas, sound-reducing techniques can be used to supplement sound absorption. Sound-reducing constructions using the mass-spring-mass principle, or sound capsules, can be particularly useful in reducing noise emissions from industrial processes into the ambient environment, especially in urban areas.

ISOVER mineral wool with high longitudinal air flow resistance values, high elasticity and high  $\alpha$  sound absorbing values can reduce sound emissions in these constructions significantly. With the ISOVER U TECH range, significant weight savings of up to 50 % can also be achieved, compared to traditional stone wool constructions, the same for TECH glass wool solutions at lower temperatures.

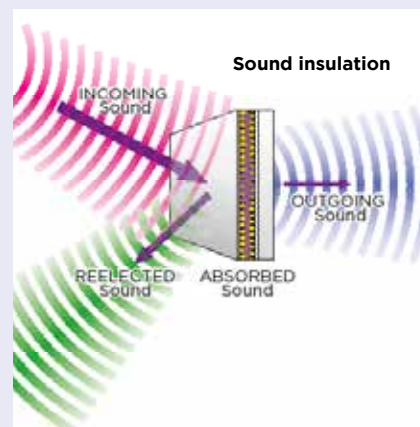



## 1.5 Giving fire no chance

**The risk of fire in industrial environments is much higher than in buildings and other applications, particularly when working with welding and grinding equipment in high-temperature environments containing flammable and /or explosive media.**



In order to protect personnel and equipment, it is important that all steps are taken to shield possible fire sources and prevent fires from starting.

Passive fire protection using non-combustible materials is the best way to eliminate these risks from the beginning or prevent fire from spreading.

That is why all ISOVER industrial insulation products offer outstanding fire safety properties.

### Best-in-class

ISOVER industrial insulation solutions offer 'best-in-class' fire safety properties. They are non-combustible and classified in Euroclass Group A – the very top classification for fire performance.

ISOVER insulation materials will not ignite, so there is no risk of fire caused by flying sparks from welding and grinding work carried out close to the insulation. In addition, ISOVER insulation materials generate practically no smoke and toxic gases, which is critically important for your employees, and for fire brigade personnel, should the worst come to the worst and a fire occur.

With ISOVER TECH industry insulation solutions, you can feel safe in the knowledge that you will never be exposed to harmful gases from the insulation materials – and that you have done everything you can do to protect your plant – and your business.

Single-Burning-Item (SBI-) oven for the determination of reaction to fire class according to EN 13501-1.

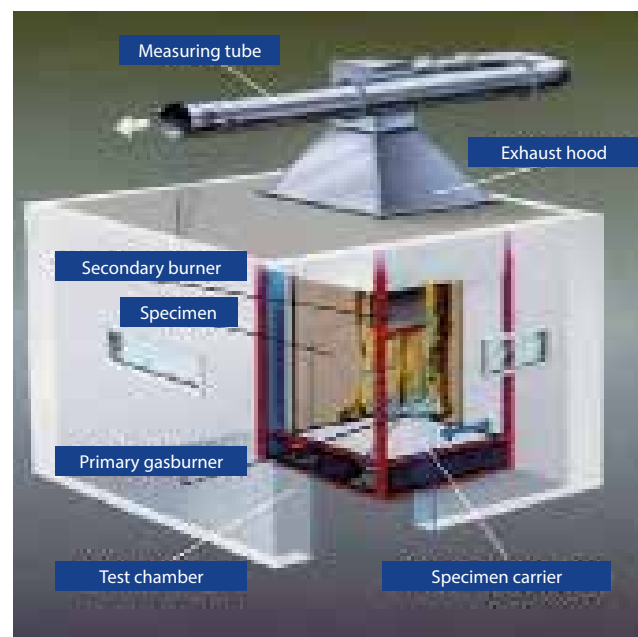

## 1.6 Corrosion protection



### Humidity and corrosion protection

**Highly alloyed austenitic steels (alloys of chrome, nickel and molybdenum) are predisposed to tensile stress corrosion (stress corrosion cracking), caused mainly by water soluble ions, such as chlorides. As the temperature increases, so does the risk of stress corrosion cracking. All ISOVER industrial TECH products are therefore low in chlorides.**

### Moisture and water repellence

Low chloride insulation products are the basis for preventing corrosion under insulation (CUI), especially where higher temperature surfaces are involved. In addition, all ISOVER industrial insulation products for external use are hydrophobic and non-hygroscopic, thus limiting potential water absorption. The open cell structure allows products to dry out quickly, should they become wet, without loss of their mechanical or insulating properties.

Hydrophobic performance is tested and measured according to AGI-Q 132, which allows for water absorption of less than 1 kg/m<sup>3</sup> after 24 hours. Nevertheless, mineral wool products should always be stored inside and in dry conditions, in order to maintain their performance and low chloride content. When used for outdoor applications or on cold surfaces, metal sheet jacketing or equivalent vapour barriers should always be used.

Acceptable analysis of water-leachable ions in mineral wool according to Karnes diagram

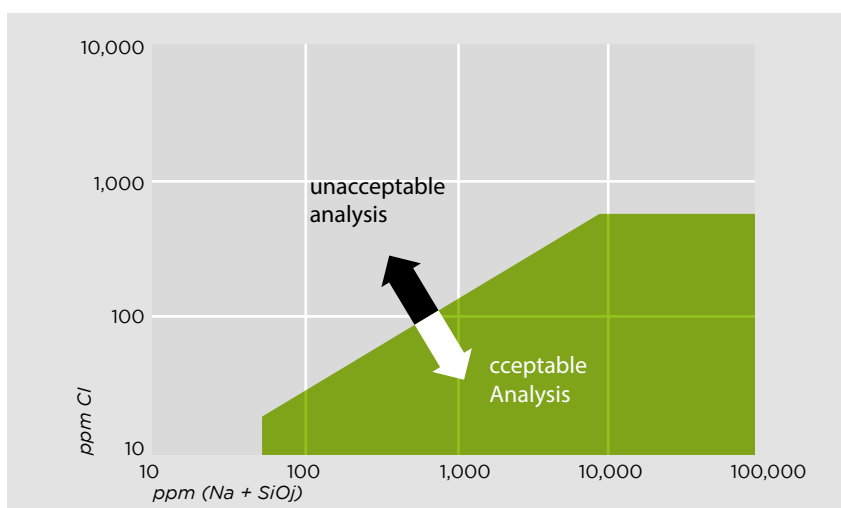

### Standards and guidelines

There are different standards to define the limits for water-leachable ions in insulation products:

- ASTM C 795, for instance, concerns the water-leachable content of chloride ions, sodium and silicate.
- The so-called Karnes diagram defines an acceptable area which is identified as not supporting stress corrosion. All ISOVER TECH products fall within the acceptable area.
- AS-Quality (AGI-Q 132): even more demanding is the AGI-Q 132, which sets the maximum content of chloride ions at 10 ppm or 10 mg per 1 kg of insulation material. Insulation materials which satisfy this standard are certified for AS-Quality. Austenitic (AS) is a term which describes a particular type of crystalline steel structure. ISOVER has certified critical TECH products for high-temperature usage as AS-Quality – giving additional safety to highly demanding constructions.



## 1.7 Environmental protection

### Eco-designed sustainable performance

ISOVER is committed to sustainability and eco-design - not only of its TECH product range for higher efficiency, especially in higher temperatures, but also for the environmental, health and safety aspects of its materials and own production processes.

### Thermal efficiency classes

ISOVER TECH products are achieving the best thermal performances and are named and classified according to their thermal efficiency potential and

service temperature recommendation. The right choice of the most suitable thermal insulation product in industry applications has never been made easier.

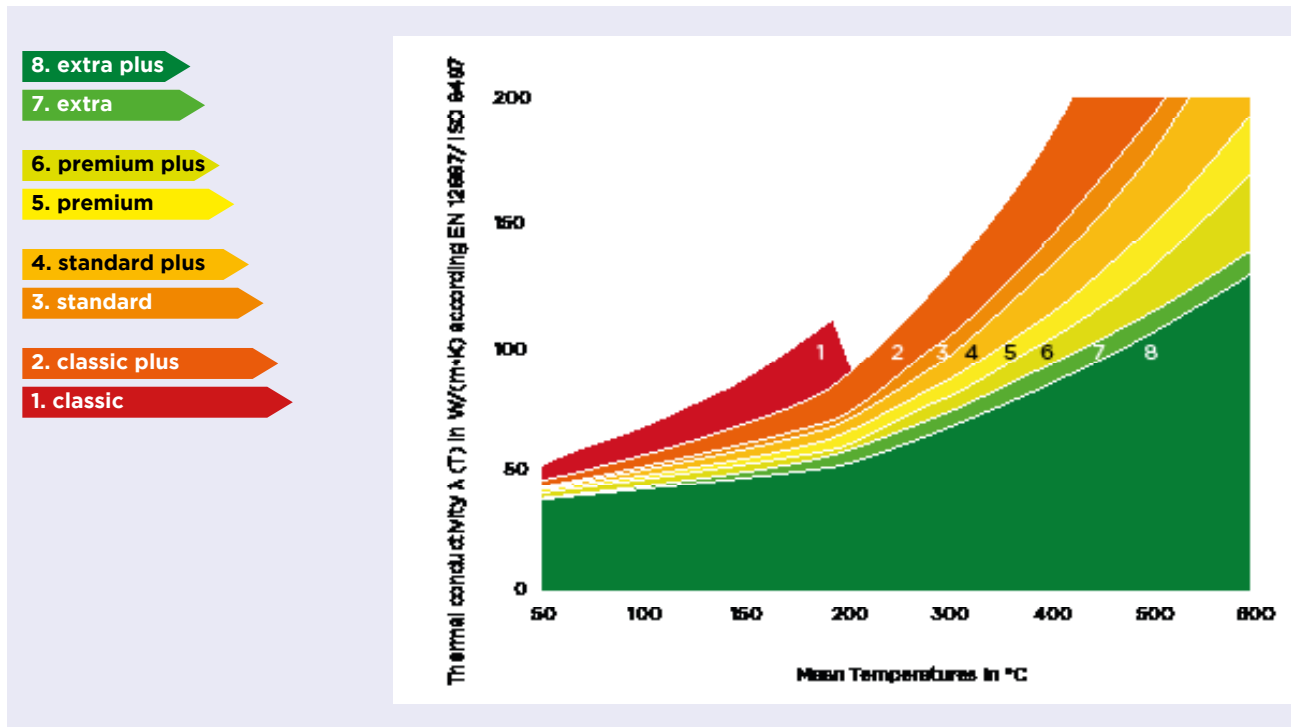

### The reference for sustainability that pays off

ISOVER offers insulation solutions that help protect the climate and environment in a sustainable way. During the last 25 years ISOVER has produced about 1.5 billion m<sup>3</sup> of insulation material. That is equivalent to a reduction of about 300 million tons of CO<sub>2</sub> emissions. ISOVER constantly works to improve not only the thermal performance of its insulation products but also the resources necessary to manufacture them.

Therefore the positive balance of energy and emissions of ISOVER materials is often achieved in industry application in a few days and pays off afterwards continuously – due to the inorganic material basis for the whole life-time of the installation.

ISOVER mineral wool is biosoluble, risk-free for health and EUCB and/or RAL certified.



### The reference for sustainable production processes

ISOVER converts about 1 m<sup>3</sup> of raw materials into up to ca. 150 m<sup>3</sup> of mineral wool. ISOVER insulation products are saving up to 250 times the energy needed during production.

Over the last 20 years, ISOVER has reduced worldwide the energy consumption by more than 20 % and the water consumption in its glass wool plants by more than 30 %. More than 75 % of the production waste is recycled. Up to 80 % of recycled glass is used as a raw material source, e.g. for glass wool production.

ISOVER organisations are certified according to ISO 9001; most of its plants are also certified according to ISO 14001 and have started the ISO 50001 certification.



## 2 ISOVER TECH Range

### 2.1 ISOVER TECH European product range - For improved energy efficiency in industry



**ISOVER TECH stands for the new CE-marked and harmonised European product range for industry insulation with guaranteed technical excellence and high performance.**

An (r)evolution in industry insulation - with the TECH product range, ISOVER moves away from the traditional specification method in industry of indicating weight only, to focus on performance-based values instead.

Consequently, each product of the ISOVER TECH range will highlight energy efficiency and sustainability classification together with the operating temperature designation. Additional indications of product form, facings and special applications will make the choice and differentiation between products easier and help in choosing the right material with the right properties.

#### ISOVER TECH European naming structure for industry products

Example: **U TECH Wired Mat MT 6 .0 Alu1 X-X EX**

U
TECH
Wired Mat
MT
6
.0
Alu1
X-X
EX

1
2
3
4
5
6
7
8

**1 Material indication for ULTIMATE only**  
quality mark for high performance at higher temperatures

**2 TECH - ISOVER product group**  
indicating one product range specially designed for all industry applications

**3 Product form**  
product supplied as: *Wired Mats, Industry Rolls, Crimped Rolls, Lamella Mats, Pipe Sections, Industry Slabs, Loose Wool*

**4 Operating temperature range**  
indicating thermal use

CRYOLENE    *for cryogenic temperatures*

Tech            *for standard temperatures up to 400 °C*

Tech MT        *for medium-high temperatures up to 700 °C*

Tech HT        *for high temperatures ≥ 700 °C*

**5 Thermal efficiency class**  
*indicating thermal performance of the product at various temperatures*

**6 Product version**  
*indicating different characteristics of products within same thermal efficiency class*

**7 Facing type**  
*indicating product with additional facing*  
Alu1, Alu2    *alu-foil facing, product classified non-combustible A1, A2-s1,d0*  
V1, V2        *veil/tissue facing of neutral or black colour*  
X, X-X        *Wired Mat stitched with stainless wire, Wired Mat stitched with stainless wire and wire mesh*

**8 Special applications**  
QN    *indicating special quality for nuclear applications*  
EX    *indicating special quality for explosion risk areas e.g. handling of liquid oxygen and requiring insulation with less than 0.5 % total organic content (AGI-Q 118).*

## 2.2 The right solutions for all temperatures

**ISOVER TECH offers you the widest product and mineral wool material range optimised for all process temperatures from cryogenic, standard, medium to high temperatures up to 700 °C. It takes the best advantages of each mineral wool type that best fits each application demand and benefits from a wide selection of product forms adapted to the insulation surface.**

Cryogenic temperature insulation	Standard temperature, sound insulation	High temperature, efficient / mechanical insulation
- 200 °C	250 °C	400 °C
<b>CRYOLENE</b>	<b>TECH glass wool</b>	<b>U TECH ULTIMATE / TECH stone wool</b>



### ISOVER CRYOLENE and TECH glass wool products

The right solutions for cryogenic and standard temperatures as well as acoustic insulation: light, flexible and resilient.



- Excellent thermal insulation
- Unique light weight
- Easy and fast installation
- Effective acoustic protection
- Effective fire protection
- Cost-effective solutions
- Transport and storage savings by high compression
- Active environmental protection
- Maximum flexibility
- High mechanical strength



### ISOVER TECH stone wool products

The right solutions for medium to high temperatures and mechanical demands for high compressive strength: robust, economic and proven.



- Excellent thermal insulation
- High service temperatures
- Easy and fast installation
- Effective acoustic insulation
- Effective fire protection
- Cost-effective solutions
- Active environmental protection
- High mechanical strength



### ISOVER U TECH ULTIMATE products

The right solutions for high performance in higher temperatures combining the advantages of glass wool and stone wool: efficient, light and space-saving.

- Up to 35 % increase in thermal performance
- Up to 30 % savings in required insulation thickness
- Up to 50 % savings in weight

- Excellent thermal insulation
- High service temperatures
- Thin solution
- Unique light weight
- Easy and fast installation
- Effective acoustic protection
- Effective fire protection
- Cost-effective solutions
- Transport and storage savings by high compression
- Active environmental protection
- Maximum flexibility

## 3. Materials

### 3.1 Glass wool

**ISOVER glass wool insulation is ideal for many low to mid-temperature (up to 400 °C) industrial applications, as it combines high thermal insulation performance with noise control, fire safety, light weight and economy.**

**ISOVER glass wool products offer state-of-the-art insulation, constantly improved and developed by Saint-Gobain ISOVER over more than 70 years to ensure that they provide the very highest levels of consistent quality and performance, with dozens of new patents filed every year.**

**Manufactured from locally-sourced natural raw materials like sand, ISOVER glass wool products today include up to 80 % recycled glass, making them the perfect choice to meet environmental concerns.**

**ISOVER offers a wide range of glass wool products designed specifically for the industrial sector. These products provide a mix of important benefits including flexibility and lightness as well as excellent compression for transport optimization and fast installation with fewer joints and therefore fewer thermal bridges.**

**The complete solution adapted to all your needs.**

### Manufacturing process

#### 1 Composition

Glass wool is made mainly of sand, soda-ash, limestone and recycled glasses. The raw materials are stored in silos, automatically weighed, mixed and poured into the furnace by an automatic batch feeder.

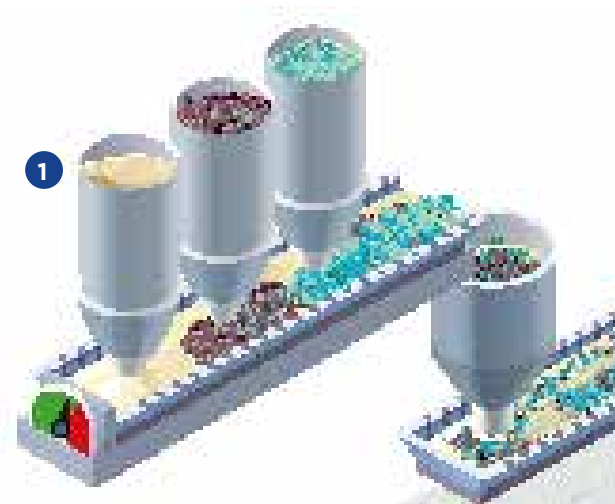

6

#### 6 Packaging, palletization

The end of the line is generally equipped with a rolling machine for mats and a stacking machine for boards.

The glass wool can be compressed to up to a tenth of its volume, reducing considerably transport and storage expenses as well as waste on sites. Units are then gathered on pallets, improving the efficiency of logistics operations.

On a pallet, 36 rolls of glass wool can be packed up.

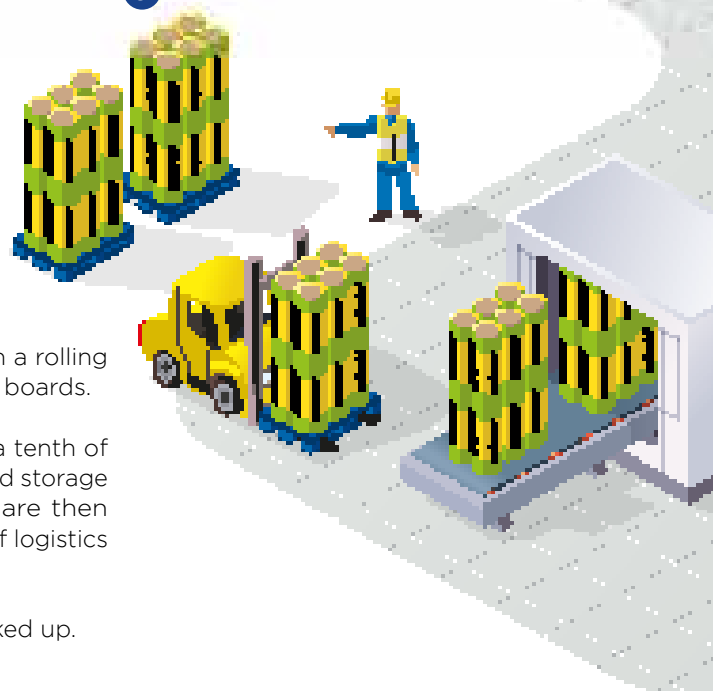

## 2 Glass wool melting

The melting of the mix is obtained at a temperature exceeding 1,400°C in an electrical furnace.

## 3 TEL fiberizing, binder

Through a feeder, the glass flows to the fiberizing machine. As it flows, the glass reaches the required temperature to be converted into fibres. The main part of the TEL fiberizing machine is the centrifugal spinner rotating around a vertical axis. The band of this spinner in refractory steel is drilled with multiple holes of about 1 mm diameter each.

Glass is centrifugally pushed through these holes and divided into a multiplicity of primary streams. A strong jet of hot gases then realizes the final "drawing" of the fibres. A binder is sprayed automatically on the fibres by spray nozzles.

## 4 Forming, curing

The products impregnated with resins are then taken to a curing oven heated at 250 °C. The hot air flows through the glass wool blanket and, while curing the fibres, gives a correct rigidity. The binder becomes yellow.

## 5 Cutting

At the exit of the curing oven, circular saws or high-pressure water jets split the blanket according to its trade width. The final presentation varies from rolls to slabs, according to the end-use application. Off-cuts are also recycled into the production process. The belt then transports the blanket to a gluing station where it can receive either a vapour barrier facing paper or aluminium, or a bonded mat or PVC coating.

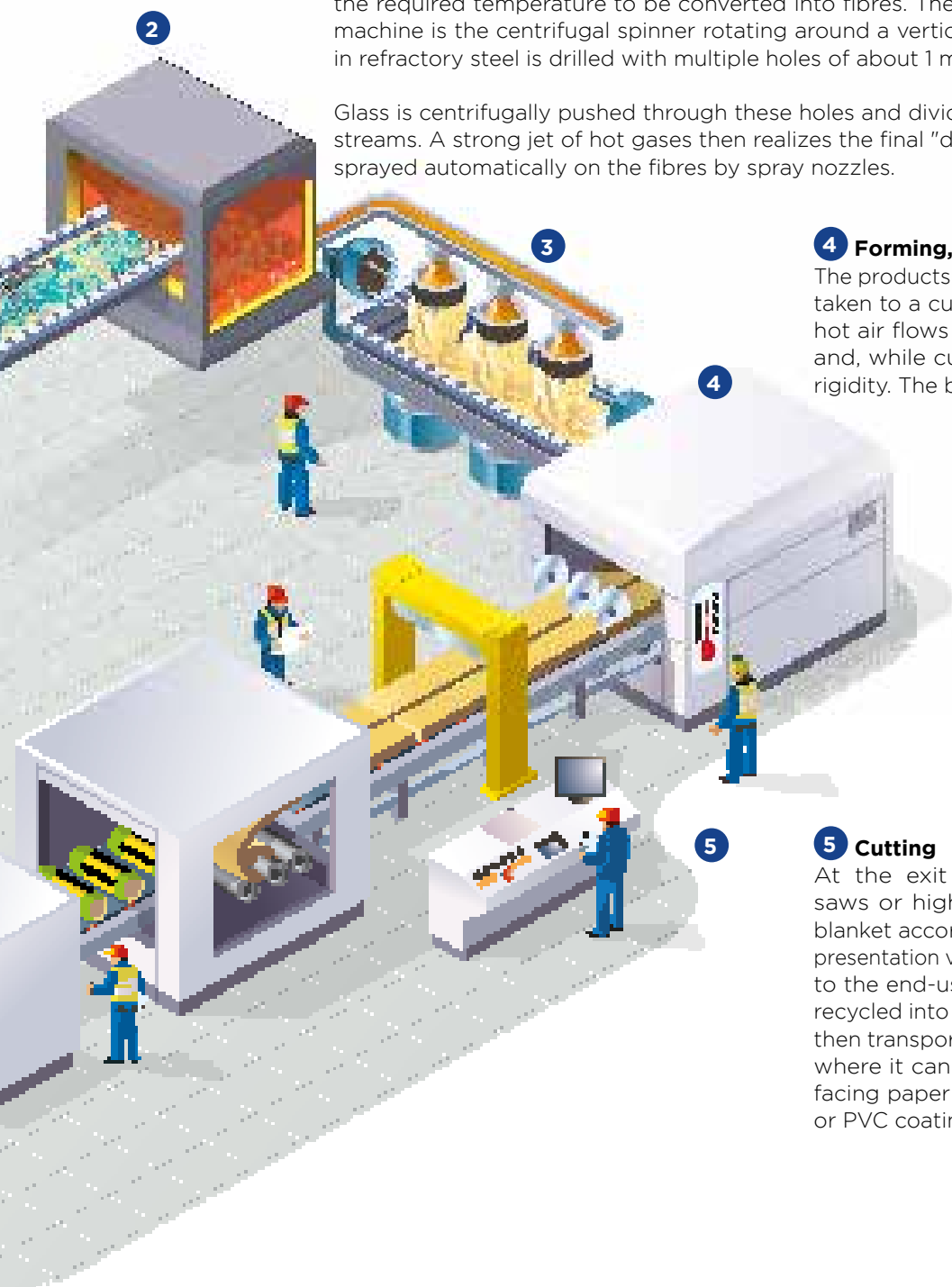

### 3.2 Stone wool

**Stone wool is ideal for many standard industrial applications as it combines good insulation performance with high-temperature operation.**

ISOVER stone wool products are made from rock - a natural material present in large quantities throughout the earth. The raw materials are mineral, and include basalt, diabase and other igneous rocks, which are melted in a cupola with fueling and fluxing agents. Up to 3% of stone wool waste is added to the mix.

Stone wool is ideal for many standard industrial applications as it combines good insulation performance with high-temperature operation (up to 700 °C MST), and the low compressive strength and high mechanical strength required for many applications. The cost-efficient product is available in a range of thicknesses and performances to suit different requirements.

**The strong solution - designed for you**

### Manufacturing process

#### 1 Composition

Stone wool consists mainly of basalt, slag and briquette (recycled stone wool). These raw materials are stored in silos and are automatically weighed and mixed with coke to form a fill that is placed in the cupola.



#### 6 Packaging / Palletization

Once out of the oven, saws cut the blanket to the required width. The generated edge waste is recycled during the manufacturing process.

The stone wool blanket is then directed towards the surfacing where the products can be covered with a paper or aluminium covering, a glass or asphalt mat.

The end of the line is equipped with a rolling machine for rolls and a staking machine and a packer for slabs.

The packages are then gathered in pallets facilitating the logistics of handling, storage and loading in the transport units. The final product is available in rolls and panels.



## 2 Fusion

The fusion of this mixture is obtained by coke combustion in a cupola heated to a temperature of over 1,500 °C.

## 3 REX fire drawing / Binder

The fibre drawing is performed by projecting glass on rotors turning at high speed. A binder is automatically atomized on the fibres that are transported by a strong air jet to the receiving station. The fibre core is placed in an underpressure chamber to form a homogeneous primary sheet with low base weight. This blanket is transported to the batting installation.

## 4 Batting creeping

An arm stacks the stone wool, zigzagging perpendicularly on a mat underneath. Batting allows an increase of the number of layers for a wide range of basis weights. Using a roller system, the wool blanket, consisting of several layers, can be directed and compressed. Crimping allows the fibres to straighten out in order to improve the mechanical characteristics.

## 5 Polymerization

The products impregnated with binder are transported to an oven heated at over 200 °C. The hot air that passes through the stone wool blanket polymerizes the resin, which gives the blanket its final thickness and consistency. During the curing operation, the stone wool blanket becomes ochre.

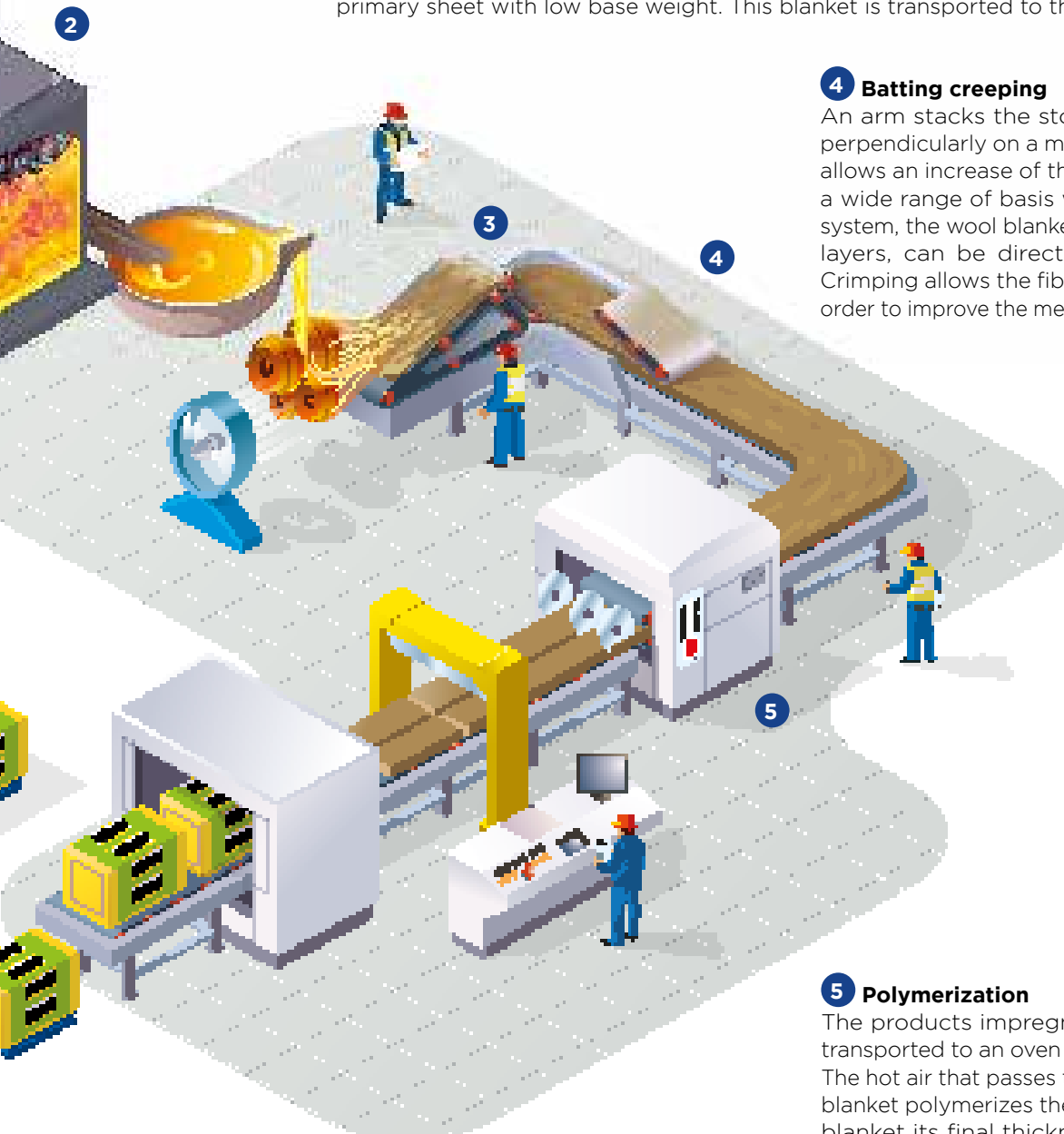

### 3.3 ULTIMATE

#### **ULTIMATE is an innovative mineral wool combining the performance benefits of glass wool and stone wool**

ULTIMATE is a groundbreaking innovation in mineral wool, a material that truly demonstrates Saint-Gobain ISOVER technological leadership in insulation products. It represents a completely new generation of insulation to add to the wide range of mineral wools, foams and other insulants now available from ISOVER worldwide.

ULTIMATE is a unique and innovative product that provides a combination of outstanding benefits for customers that are not available in any other single insulation product:

- Excellent thermal and acoustic performance
- Highest performance in fire safety and high-temperature operation
- Significant time, space and weight savings
- Excellent comfort and safety

#### **Manufacturing Process**

ULTIMATE is manufactured using a similar process to that used for glass wool. However, the challenge for the development team was to develop a product capable of operation at much higher temperatures than traditional glass wool products. This was achieved following a breakthrough involving a new patented glass composition and extensive conversion of the basic glass wool manufacturing process.

The process is entirely patented.

In order to create a brand new mineral wool that combined the high-temperature performance of stone wool with the thermal, acoustic and low weight benefits of glass wool, it was originally thought that the answer would be found in a development of the stone wool process. The result was actually achieved by developing a new glass wool-based product with exceptional high temperature resistance.

Two main developments made this possible:

- Firstly, a new type of glass wool, with a composition similar to that of stone wool, had to be developed. As well as meeting demanding performance criteria, it also had to conform with European/national standards concerning fibre biosolubility to the human body.
- Secondly, new high-temperature melting and fiberizing processes had to be developed.
- The new process is similar to that for glass wool, except that the temperatures are some 200 °C higher, with glass in the fiberizing spinner reaching a temperature of 1,200 °C.

### Manufacturing process





## 4. Environment, health & safety

### 4.1 Saint-Gobain's EHS policy

Saint-Gobain designs, manufactures and distributes materials, services and solutions which are key contributors to our sustainable wellbeing. Through our commitment to environmental, health and safety excellence, we affirm to all our stakeholders, including our employees, customers, suppliers, shareholders and the public, that we aim to work collaboratively to bring sustainable, market-driven and innovative solutions, making lives better, safer and healthier for people everywhere.

We believe that any injury, occupational illness or environmental accident is unacceptable. Excellence in environment, health and safety is contributing directly to the improvement of working conditions, to the operational excellence and to the wellbeing of all. Our ultimate goal is: zero work-related accidents, zero occupational illness, zero environmental accidents and minimum impact of our activities on the environment. We establish and maintain our standards and best practices in light of advances in technology and science and aim at a wide implementation. We strengthen our businesses by making safety, health and environment central to our culture.

We assess the impact of any site we propose to construct or acquire and we design and build all our sites so that they are safe, secure and acceptable to the environment.

We continuously analyse our practices, processes and products to minimize their environmental, health and safety risks and impacts and to maximize their benefits. We measure and regularly report our global progress in meeting this engagement.

### 4.2 Protection of the environment

Protecting the environment in the Group's operations requires constant commitment and continuous attention. Saint-Gobain's teams are focused on achieving the objective of zero environmental accidents and a minimum impact on the environment..

#### Committed to setting an example

Saint-Gobain works to preserve the environment from the potential impacts of its processes and services. Four priorities have been identified to fight against climate change:

- Assess and manage risks.
- Implement best existing techniques and practices.
- Innovate to invent the best future techniques and practices.
- Involve employees over the long term in protecting the environment.

Tools have been developed to help all Group sites make progress on the basis of a shared methodology.

#### Long-term objectives:

- Zero environmental accidents,
- Minimum impact from Saint-Gobain activities on the environment.

#### Major environmental challenges

##### Raw materials and waste

Reducing waste is a priority for the Group. In addition to recovering its own production waste, Saint-Gobain also uses recycled materials from outside sources, such as cullet and recovered scrap metal, to optimize its raw material consumption.

The primary method for reducing resource consumption in glass furnaces is to include cullet (crushed recycled glass) among the raw materials.

#### Objective for 2025:

- Reduce non-recovered waste by 50 % (base 2010),
- Long-term objective: Zero.

## Energy, atmospheric emissions and climate change

### Objectives:

- Energy consumption: -15 % (2010–2025)
- Total CO<sub>2</sub> emissions: -20 % (2010–2025)
- Emissions of NO<sub>x</sub>, SO<sub>2</sub>, and dust: -20 % for each emissions category (2010–2025)

CO<sub>2</sub> is the main greenhouse gas emitted by the Group's activities. A carbon assessment was conducted at 31 Saint-Gobain companies in France, representing 75 % of the Group's total workforce, taking into account emissions from energy use, processes, shipping, commuting and business travel and raw material purchasing.

Saint-Gobain has participated in the Carbon Disclosure Project (CDP) since 2003.

## Water

Saint-Gobain's water policy, published in 2011, applies to all Group sites worldwide. It confirms the Group's commitment to reducing the quantitative and qualitative impact of its activities on water resources as much as possible, in terms of both withdrawals and discharges. Since 2012, the Group has participated in the CDP Water Disclosure, which is designed to encourage companies to produce a detailed report of the risks and opportunities in their water management and to communicate the results in a transparent manner.

### Objectives for 2025:

- Reduce industrial effluent by 80 % (base 2010),
- Long-term objective: Zero.

## Biodiversity

### Objective:

Carry out local biodiversity studies for new sites and quarries and restore sites and quarries in cooperation with stakeholders, taking local biodiversity into account.

The Group operates 151 underground and open-cast quarries worldwide. Of these, 79 % belong to the Gypsum Activity, which has issued a biodiversity charter for its quarries. The Group's quarries are operated with the goal of preserving the environment, in compliance with local regulations.

A biodiversity action program has been launched at the Group scale to improve knowledge of Saint-Gobain's natural assets. This method represents a first step in developing a cross-functional policy.

### 4.3 EUCEB certification



EUCEB (European Certification Board for mineral wool products) is a voluntary initiative by the mineral wool industry. It is a certification authority that monitors that mineral wool products are made of fibres not classified in Regulation (EC)

No 1272/2008. To ensure that fibres comply with the Note Q criteria, all tests and supervision procedures are conducted by independent and qualified experts and institutions.

Manufacturers' commitments to get their products EUCEB certified are as follows:

- To provide test reports from a laboratory recognized by EUCEB justifying that the fibres meet one of the criteria of Note Q of Regulation (EC) No 1272/2008.
- To submit to conformity inspection at least twice a year by independent institutes recognized by EUCEB: products sampling and chemical analysis, which has to be similar to one of the tested fibres.
- To have internal quality controls in the plant(s).

### 4.4 Safe Use Instruction Sheet (SUIS)

The European Regulation (ER) on Chemicals N° 1907/2006 (REACH) enforced on June 1st 2007 requires a Material Safety Data Sheet (MSDS) only for hazardous substances and mixtures/preparations. Mineral wool products (panels or rolls) are articles under REACH and therefore MSDS is not legally required. Nevertheless, Saint-Gobain ISOVER decides to provide its customers with the appropriate information for assuring safe handling and use of mineral wool through this Safe Use Instructions Sheet.

Therefore, Safe Use Instruction Sheets similar to a safety data sheet are available and recommendations are given to the users when the insulating product is installed.

The following parameters can be found in the Safe Use Instruction Sheet:

- Hazards identification
- Composition / information on ingredients
- First aid measures
- Firefighting measures
- Accidental release measures
- Handling and storage
- Exposure controls / personal protection
- Physical and chemical properties
- Stability and reactivity
- Toxicological information
- Ecological information
- Disposal considerations
- Transport information
- Regulatory information

## 4.5 Environmental Product Declaration (EPD)

An Environmental Product Declaration describes the environmental performance of a product and encourages the development of environmentally friendly and healthy construction.

This declaration is based on a life cycle analysis of the product during its whole life and provides indicators according to the standard EN 15804 "Sustainability of construction works - Environmental product declarations - Core rules for the product category of construction products" and specific product category rules for mineral insulating material.

For industry applications, this declaration contains a product definition, information about basic materials and sources of the materials, descriptions about the

material production, information about the material processing and about the state of usage, extraordinary impacts and phase after utilization.

Knowing the product and how impacts in each life cycle are calculated is helpful for users.

ISOVER has for many years implemented action plans to reduce and limit the need for natural resources, particularly the water and energy required for the manufacturing of its products. We strive to provide our customers with products and solutions that help reduce the environmental impact throughout their life cycle.



## 5. Standards for industry applications

### 5.1. Standardization bodies

Depending on the type of standardization, standards are developed by standardization bodies at national, European and international levels.



#### 5.1.1. European Committee for Standardization

CEN is the European Committee for Standardization created in 1961, originally by the standardization bodies of France, Germany and Benelux, and with the aim of harmonizing the standards developed in the different European countries. The CEN today has widened to all European Union member countries with a national standardization body, as well as to the three EFTA (European Free Trade Association) countries, Iceland, Norway, and Switzerland. Recently, countries such as Croatia, Turkey and the Former Yugoslav Republic of Macedonia have also joined CEN.

This European standardization work consists of drawing up European standards, but also updating them in the three official languages: English, German and French.

The European standards, recognizable by the prefix EN which introduces them, are elaborated by the CEN and published in the form of national recovery in the normative collections of the members with suppression of contradictory standards.

In some cases, the so-called "harmonized" European standards also allow actors to apply European legislation; they are cited in the relevant Directive in the Official Journal of the European Union (OJEU). These European directives "New Approach Directives" define the essential requirements that all products must meet before being placed on the European market.

For insulation materials used in industrial applications, the document of reference, since July 1st, 2013, and of compulsory application, is the Construction Products Regulation (CPR) for the implementation of the CE marking of the products of construction, abrogating the Directive 89/106 / EEC Construction Products (CPD).

This harmonized European standard has an Annex ZA containing all these indications: intended uses, declaration of performance, system of evaluation and verification of the constancy of the performance.



#### 5.1.2. International Organization for Standardization

Founded in 1947, ISO is an independent non-governmental organization, composed of members from national standards bodies. Its secretariat is based in Geneva and coordinates all the work.

ISO develops worldwide voluntary standards for products, services and good practices, established in the framework of a global consensus, thus enabling the efficiency of all economic sectors and the elimination of all obstacles related to international trade.



#### 5.1.3. ASTM International

Formerly known as the American Society for Testing and Materials, is an international standards organization that develops and publishes voluntary consensus technical standards for a wide range of materials, products, systems, and services.

Founded in 1898 as the American Section of the International Association for Testing Materials, ASTM International predates other standards organizations such as the BSI (1901), IEC (1906), DIN (1917), ANSI (1918), AFNOR (1926), and ISO (1947).



#### 5.1.4. CINI - International Standard for Industrial Insulation

Around the world, the standard of CINI (Committee Industrial Insulation) is used when thermal insulation work needs to be engineered and carried out. On July 28, 1989 CINI was established and has evolved since to be the standardization institute for insulation in the field of the (petro) chemical industry, process industry, power plants, LNG terminals etc. CINI acts as the insulation focal point for principals, insulation companies, material suppliers, consultants, branch organizations, training institutes and also governmental organizations such as the Ministry of Economic Affairs.

## 5.2. Other technical specifications, guidelines



### 5.2.1. AGI

#### Worksheet Q132 on mineral wool as an insulating material for industrial installations

This working document applies to mineral wool insulants which are used for thermal, cold and acoustical insulation of technical installations in industry and in building equipment. Explanations about the production of mineral wool are given in Annex A.

This document does not apply to insulants made of ceramic fibres or of calcium-magnesium-silicate fibres (CMS fibres).

In December 2016, the Arbeitsgemeinschaft Industriebau eV (AGI) published the AGI worksheet Q132 "Insulating materials for technical installations - mineral wool" in a newly revised version.

It describes in detail mineral wool insulation materials that are used for thermal, cold and sound insulation of industrial installations and in technical building equipment. Delivery forms, substances, requirements for mineral wool insulation, markings, tests and quality assurance are described exactly.

#### AGI index for mineral wool insulating materials.

For insulating materials, the introduction of the EN standards in the context of the CE marking has defined the specification of the essential characteristics on the label and in the manufacturer's declaration of performance (DoP). The worksheet supplements this designation key for corresponding products in accordance with point 6 of EN 14303 by the "AGI code number". It contains the following additional material properties: the bulk density required for determining the load, e.g. for the design of pipe supports, the limit curve of the thermal conductivity, e.g. for the manufacturer-independent calculation of insulation thicknesses, and the length-related flow resistance, e.g. for the estimation of convection and acoustic properties.



#### Guideline VDI 2055 Part 1: Calculation procedures for effective insulation in protection against heat and cold

Available in September 2008, guideline VDI 2055 Part 1 from the VDI Society for Energy Technology deals with the protection against heat and cold not only of pipes, conduits, tanks, apparatus and machines but

also in cold-storage facilities. It defines procedures for calculating heat and diffusion flows in insulating materials and for determining insulating layer thicknesses in accordance with technical and economic viewpoints.

A considerable amount of new material has been added to the new guideline: thermal insulation of heated and refrigerated operational installations in industry and building services; calculation rules. In comparison with the old 1994 edition, it provides precise instructions for calculating the operational heat conductivity of insulation, with particular inclusion of dampness and convection. In addition, it specifies reference values and temperature functions for the thermal conductivity of different groups of insulating material and the forms in which it is supplied. The guideline now includes not only calculation procedures for the coupled transportation of moisture and energy in low-temperature insulation, but also simplified calculation methods for heat loss from pipes in floors and walls in the building services field. The guideline also deals with calculation procedures for insulation-related thermal bridges and makes it possible to determine economically efficient insulating layer thicknesses of multi-layered insulation. The symbols used in the guideline for the most part conform with European standardization. Guideline VDI 2055 Part 1 is aimed at planning engineers seeking an efficient design solution for their insulation, manufacturers of insulating materials and also inspection and monitoring bodies.

#### European INSULATION VDI Scheme for Thermal Insulation Products

The purpose of the document is to establish methods for calculating heat flow rates, dimensioning the insulating layer from the point of view of operational and economic considerations, demonstrating from a technical point of view that guarantees are fulfilled, and the technical conditions for supplies and services.

Insulation materials for industry and operational installations for buildings have to fulfill further requirements as a basis for design. VDI introduced certification of industrial insulation according to the standard VDI 2055 in 1990 with the central items of third party control of the properties listed in the product data sheet and factory production control.

Now these products according to the standards EN 14303 to EN 14309, EN 14313 and EN 14314 can be labelled with the Keymark, the VDI-mark or with both marks.

The QAC (Quality Assurance Committee) has established a voluntary system, which checks the conformity of products with all declarations in the manufacturers' product data sheets, and attests the conformity with a certificate. The tests are conducted by independent accredited test- and supervision bodies (registered testing laboratory) at least once a year. The evaluation of conformity is done by an independent accredited certification body.

### 5.3. Relevant properties for an insulation product

All relevant properties for an insulation product are described in test method standards for:

- Thermal performance: thermal conductivity
- Fire reaction: response of a product in contributing, by its own decomposition, to a fire to which it is exposed, under specified conditions
- Contribution to fire: energy released by a product influencing the fire growth in both pre- and post-flashover situations
- Compressive strength
- Maximum service temperature
- Water behaviour: liquid water absorption, vapour (water) tightness / sorption
- Chemical behaviour
- Other (acoustical, etc.)

### 5.4. List of applicable standards and reference documents

#### 5.4.1. Harmonized standard

##### **EN 14303: Thermal insulation products for building equipment and industrial installations – Factory-made mineral wool (MW) products – Specification**

Specifications of the characteristics for mineral wool products are given, including all the procedures for testing, evaluation of conformity, marking and labelling.

The intended uses of mineral wool products are for the thermal insulation of building equipment and industrial installations with an operating temperature range of approximately 0 °C to 800 °C.

#### 5.4.2. International standards. Test methods

##### **Thermal properties**

##### **ISO 10456: Building materials and products – Hygrothermal properties – Tabulated design values and procedures for determining declared and design thermal values**

Methods for the determination of declared and design thermal values are given; tabulated design values are given covering design ambient temperatures between 30 °C and +60 °C.

Conversion coefficients for temperature and for moisture are also provided and are valid for mean temperatures between 0 °C and 30 °C.

##### **ISO 13787: Thermal insulation products for building equipment and industrial installations – Determination of declared thermal conductivity**

The procedure for determining and checking the declared thermal conductivity as a function of temperature of thermal insulating materials and products is described.

An optional method for establishing the thermal conductivity curve or table from measured values is given in Annex B (informative).

#### 5.4.3. European standards

##### **Properties**

##### **EN 826: Thermal insulating products for building applications – Determination of compression behaviour**

The equipment and the procedures are described for determining the compressive stress for thermal insulating products which are only exposed to short-term loads.

##### **EN 1609: Thermal insulating products for building applications – Determination of short-term water absorption by partial immersion**

The equipment and the procedures are described for determining the short-term water absorption for thermal insulating products.

##### **EN 13468: Thermal insulating products for building equipment and industrial installations – Determination of trace quantities of water soluble chloride, fluoride, silicate, and sodium ions and pH**

The equipment and procedures are described for determining trace quantities of the water soluble chloride, fluoride, silicate and sodium ions in an aqueous extract of the product.

A procedure is also described for the determination of the pH of the aqueous extract.

## Thermal performance

### ISO 8497: Thermal insulation. Determination of steady-state thermal transmission properties of thermal insulation for circular pipes

A method is described for the determination of steady-state thermal transmission properties of thermal insulations for circular pipes generally operating at temperatures above ambient.

Apparatus performance requirements are specified.

### EN 12667: Thermal performance of building materials and products – Determination of thermal resistance by means of guarded hot plate and heat flow meter methods – Products of high and medium thermal resistance

Principles and testing procedures are described for determining the thermal resistance by the guarded hot plate or by the heatflow meter methods, applicable for products having a thermal resistance of not less than  $0.5 \text{ m}^2 \text{ K/W}$ .

## Maximum Service Temperature

### EN 14706: Thermal insulating products for building equipment and industrial installations – Determination of maximum service temperature

The equipment and procedures are described for determining the maximum service temperature of flat insulation products.

### EN 14707: Thermal insulating products for building equipment and industrial installations – Determination of maximum service temperature for preformed pipe insulation

The equipment and procedures are described for determining the maximum service temperature for preformed pipe insulation

## Reaction to fire

### EN 13501-1: Fire classification of construction products and building elements – Part 1: classification using data from reaction to fire tests

The reaction to fire classification procedure is described for all construction products and building elements according to their end-use application.

## 5.4.4. ASTM

### Specifications and properties

#### ASTM E84: Standard Test Method for Surface Burning Characteristics of Building Materials

This test method gives the comparative surface burning behaviour of building materials, applicable for exposed surfaces such as walls and ceilings.

#### ASTM C167: Standard Test Methods for Thickness and Density of Blanket or Batt Thermal Insulations

These test methods cover the determination of thickness and density for thermal insulating products with or without covering or reinforcement surface.

#### ASTM C177: Standard Test Method for Steady-State Heat Flux Measurements and Thermal Transmission Properties by Means of the Guarded-Hot-Plate Apparatus

This test method gives the requirements to be fulfilled by the laboratory measurement of the steady-state heat flux through flat and thermal transmission properties using the guarded-hot-plate apparatus.

#### ASTM C335: Standard Test Method for Steady-State Heat Transfer Properties of Pipe Insulation

This test method gives the requirements to measure the steady-state heat transfer properties of pipe insulations.

#### ASTM C356: Standard Test Method for Linear Shrinkage of Preformed High-Temperature Thermal Insulation Subjected to Soaking Heat

This test method gives the requirements to determine the amount of linear shrinkage and other changes that occur when a preformed thermal insulating material is exposed to soaking heat for temperature applicable to hot-side temperatures in excess of  $150 \text{ }^\circ\text{F}$  ( $66 \text{ }^\circ\text{C}$ ).

#### ASTM C411: Standard Test Method for Hot-Surface Performance of High-Temperature Thermal Insulation

This test method gives the requirements to determine the performance of thermal insulating products when exposed to simulated hot-surface application conditions.

#### ASTM C447: Standard Practice for Estimating the Maximum Use Temperature of Thermal Insulations

This practice covers estimation of the maximum use temperature of thermal insulation products, gives performance criteria, and characterization properties during and after use conditions.

**ASTM C547: Standard Specification for Mineral Fiber Pipe Insulation**

This specification is applicable to mineral fiber pipe insulation and gives a classification into five types according to the processing method used and the operating temperatures and gives two grades depending on heating requirements.

There are requirements for the values of hot surface performance, non-fibrous content, use temperature, sag resistance, linear shrinkage, water vapour sorption, surface-burning characteristics, apparent thermal conductivity, and mean temperature.

**ASTM C592: Standard Specification for Mineral Fiber Blanket Insulation and Blanket-Type Pipe Insulation (Metal-Mesh Covered) (Industrial Type)**

This specification is applicable to mineral fiber blanket insulation and blanket-type pipe insulation and gives requirements on facings, on metal-mesh, on reaction to fire behaviour, and on the thermal insulating product.

**ASTM C612: Standard Specification for Mineral Fiber Block and Board Thermal Insulation**

This specification is applicable to mineral fiber block and board thermal insulation and gives requirements according to the properties of the thermal insulating product: compressive strength resistance, linear shrinkage, water vapour sorption, odour emission, on reaction to fire behaviour, and on the thermal insulation product.

**ASTM C692: Standard Test Method for Evaluating the Influence of Thermal Insulations on External Stress Corrosion Cracking Tendency of Austenitic Stainless Steel**

This test method describes two procedures to evaluate the contribution of a thermal insulating product to external stress corrosion cracking of austenitic stainless steel due to soluble chlorides within the insulation.

**ASTM C795: Standard Specification for Thermal Insulation for Use in Contact with Austenitic Stainless Steel**

This specification is applicable for the use of non-metallic thermal insulation in contact with austenitic stainless steel piping and equipment.

A corrosion test and chemical analysis shall be performed to conform to the specified requirements.

**ASTM C1104: Standard Test Method for Determining the Water Vapour Sorption of Unfaced Mineral Fiber Insulation**

This test method gives the requirements to determine the amount of water vapour sorbed by mineral fiber insulation exposed to a high-humidity atmosphere, applicable to fibrous base material and binder.

**ASTM C1338: Standard Test Method for Determining Fungi Resistance of Insulation Materials and Facings**

This test method gives the requirements to determine the ability of new insulation materials and their facings to resist fungal growth.

**ASTM C1393: Standard Specification for Perpendicularly Oriented Mineral Fiber Roll and Sheet Thermal Insulation for Pipes and Tanks**

This specification is applicable to mineral fiber block and board thermal insulation and gives requirements according to the properties of the thermal insulating product: compressive strength resistance, linear shrinkage, water vapour sorption, odor emission, on reaction to fire behavior, and on the thermal insulation product.

This specification is applicable to perpendicularly oriented mineral fiber roll and sheet thermal insulation for use on the flat, curved, or round surfaces of pipes and tanks.

The thermal insulating product is classified according to the maximum use temperature, the maximum apparent thermal conductivity and according to minimum compressive resistance.

The requirements on values of corrosiveness to steel, stress corrosion to austenitic stainless steel, shot content, maximum use temperature, maximum exothermic temperature rise, and compressive resistance shall be fulfilled.

#### 5.4.5. Other standards

##### Execution (German Standard)

##### **DIN 4140: Insulation work on industrial installations and building equipment - Execution of thermal and cold insulations**

Insulation work on industrial installations and building equipment is described for production and distribution systems, for example devices, containers, columns, tanks, steam generators, pipes, heating and cooling, ventilation, air conditioning, cold and hot water systems.

##### Quality management Standards (International standard)

##### **EN ISO 9001: Quality management systems - Requirements**

The requirements for a quality management system are described when an organization:

1. needs to demonstrate its ability to consistently provide products and services that meet customer and applicable statutory and regulatory requirements, and
2. aims to enhance customer satisfaction through the effective application of the system, including processes for improvement of the system and the assurance of confor with customer and applicable statutory and regulatory requirements.

##### German Specifications

##### VDI Verein Deutscher Ingenieure

##### **VDI 2055: Thermal insulation for heated and refrigerated industrial and domestic installations - Calculations, guarantees, measuring and testing methods, quality assurance, supply conditions**

##### Working documents

##### **AGI Q 132: Insulation Material for Industrial Installations**

##### CINI

##### **CINI 2.1.01: Glass wool (GW) slabs for the thermal insulation of equipment**

##### **CINI 2.1.03: Glass wool (GW) sections and prefabricated elbows for the thermal insulation of pipes**

##### **CINI 2.1.05: Glass wool (GW) lamella mats for the thermal insulation of air ducts, pipe bundles and equipment**

##### **CINI 2.2.01: Rock wool (RW) slabs for the thermal insulation of equipment**

##### **CINI 2.2.02: Rock wool (RW) wire mesh blankets for the thermal insulation of equipment**

##### **CINI 2.2.03: Rock wool (RW) sections and prefabricated elbows for the thermal insulation of equipment**

##### **CINI 2.2.05: Rock wool (RW) lamella mats for the thermal insulation of air ducts, pipe bundles and equipment**

## 2. Theory of Thermal Insulation





1.	Basic concepts.....	42
1.1.	Thermodynamics and heat transfer .....	42
1.2.	Heat transmission mechanisms .....	42
1.2.1.	By conduction.....	43
1.2.2.	By convection.....	43
1.2.3.	By radiation .....	45
1.3.	Surface heat transmission.....	46
1.3.1.	Convective part of the surface coefficient, $h_{cv}$ .....	46
1.3.2.	Radioactive part of the surface coefficient, $h_r$ .....	49
1.3.3.	Approximation for calculating the inner surface coefficient of heat transfer, $h_i$ .....	49
1.3.4.	Approximation for calculating the outer surface coefficient of heat transfer, $h_e$ .....	49
1.4.	Heat transfer by conduction in steady state ....	50
1.4.1.	In flat walls .....	50
1.4.2.	In cylinders and spheres .....	59
1.4.3.	In rectangular sections.....	69
1.5.	Thermal transmittance .....	71
2.	Temperature distribution .....	74
2.1.	Intermediate temperature .....	74
2.2.	Surface temperature .....	76
3.	Prevention of surface condensation.....	77
4.	Special application .....	78
4.1.	Longitudinal temperature change in a pipe .....	78
4.2.	Change of temperature and cooling time in accumulators and tanks .....	80
4.3.	Calculation of freezing and cooling time of liquids at rest.....	80
4.4.	Underground pipes .....	83
5.	Thermal bridges .....	84
5.1.	Average thermal conductivity .....	84
5.2.	Design thermal conductivity.....	84
5.2.1.	Correction factor F .....	86
5.2.2.	Increments of $(\Delta)$ .....	86
6.	General rules related to the installation .....	87
6.1.	Equivalent lengths.....	87
6.2.	Energy losses in supports and suspensions....	87

# Theory of thermal insulation

## 1. Basic concepts

### 1.1. Thermodynamics and heat transfer

Heat transfer is the exchange of energy that takes place between material bodies as a result of a difference in temperature.

Thermodynamics indicates that this energy transfer is defined as heat. Heat transfer intends not only to explain how thermal energy can be transferred, but also to predict how quickly, under certain specific conditions, that transfer occurs. The fact that the desired objective of the analysis is the speed of heat transfer highlights the difference between heat transfer and thermodynamics. Thermodynamics deals with systems in equilibrium; it can be used to predict the amount of energy required to bring a system from one state of equilibrium to another; but it cannot be used to predict how fast the change will be, since the system is not in a state of equilibrium during the process. Heat transfer complements the first and second principles of thermodynamics, providing experimental laws that

are used as a basis for heat transfer and are quite simple and easily extensible, so that they cover a variety of practical situations.

The essential requirement for heat transfer to occur is a temperature difference, this being its motor. There will never be a net transfer of heat between two systems that are at the same temperature. Furthermore, whenever a body has a temperature that is different from that of the medium or that of another body, heat will always be transferred between the body and the medium until thermal equilibrium is reached.

### 1.2. Heat transmission mechanisms

Heat is transferred in three different ways: by conduction, by convection and by radiation (see Figure 1). In all three cases, a temperature difference is necessary and heat is always transferred from the zone with the higher temperature to the one with the lower temperature.

Figure 1. Types of heat transmission

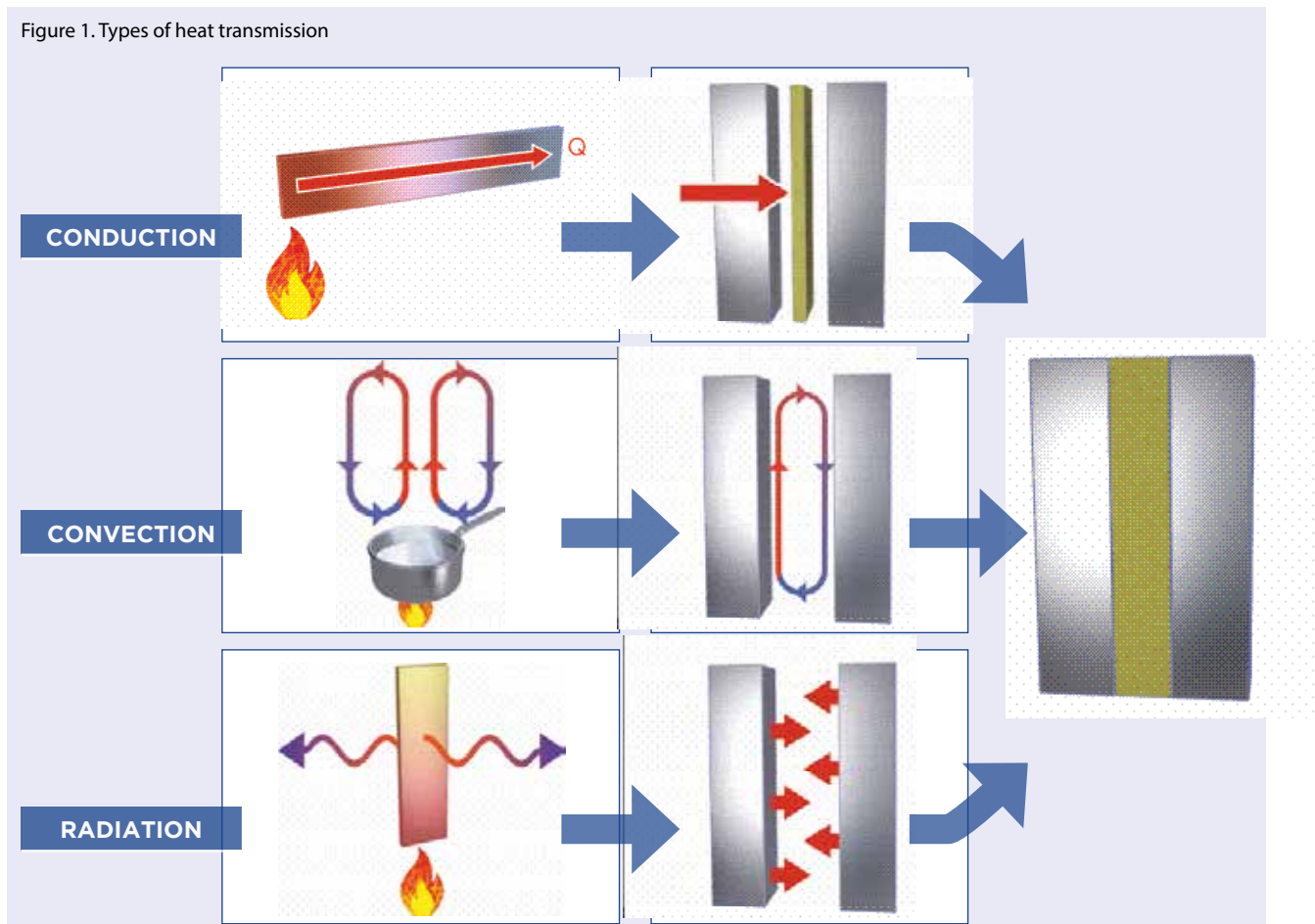

### 1.2.1. By conduction

With solids, the only form of heat transfer is by conduction. When there is a temperature difference (gradient) in a body, energy is transferred from the high-temperature zone to the low-temperature zone. In this case, the energy is transferred by conduction and the heat flow per area unit is proportional to the normal temperature gradient:

$$[2.1] \quad \frac{q}{A} \sim \frac{\partial T}{\partial x}$$

When the proportionality constant is introduced, Fourier's law of heat conduction is obtained, which is defined as:

$$[2.2] \quad q = -\lambda \frac{\partial T}{\partial x}$$

where:

$q$  heat flow ( $\text{W}/\text{m}^2$ ).

$\frac{\partial T}{\partial x}$  temperature gradient in the heat flow direction ( $\text{K}/\text{m}$ )

$\lambda$  thermal conductivity of the material, which is the measurement of a material's capacity to conduct heat. ( $\text{W}/\text{m}\cdot\text{K}$ )

The negative sign corresponds to the second principle of thermodynamics, which is that the heat flow is in the direction of the declining gradient temperature, as indicated in the coordinate system of Graph 1.

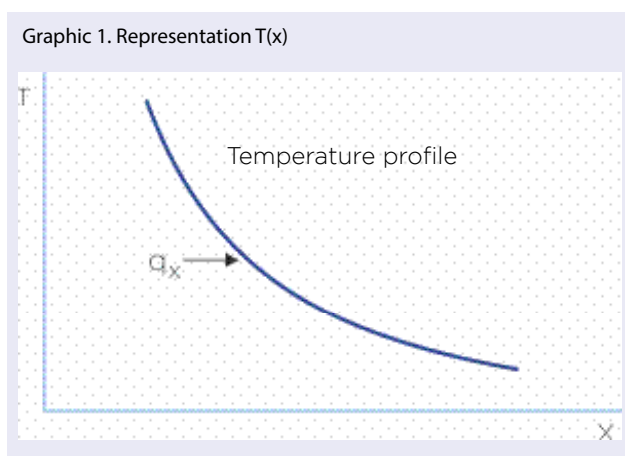
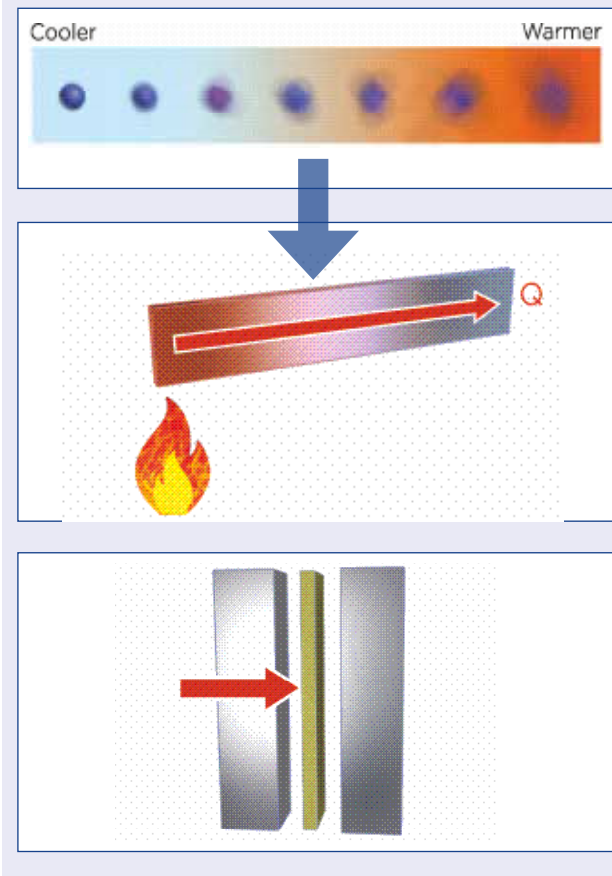

Figure 2. Particle vibration inside a metal bar.



Heat transfer by conduction is transmitted from molecule to molecule without apparent change of matter, so this form of heat change occurs mainly in solids. The elevation of temperature increases the excitation of the most elementary particles of the matter, transmitting this excitation to those closest to its surroundings along with its calorific energy, continuing the process in the body from the hottest zone to the coldest.

The speed of heat conduction through a medium depends on the geometrical configuration of the medium, its thickness and the intrinsic nature of the material, as well as its temperature gradient. For example, if we wrap a hot water tank in mineral wool, the speed at which its heat is lost is reduced. The thicker the insulation, the lower the heat loss. The larger the hot water tank, the greater the surface area and, therefore, the rate of heat loss.

It is understood that the denser, more compact and heavier a body is, the closer the molecules are to each other and, therefore, the transfer is easier.

### 1.2.2. By convection

This is the typical way of fluid propagation (both liquids and gases).

- We all know that if we place a fan in front of a hot metal plate, it will cool faster than if it were exposed to still air. In this case, the heat is emitted from the plate and the process is called heat transfer by convection.

Molecules in contact with a body at a higher temperature heat up, decreasing their density and moving by gravity. If they, in turn, come into contact with a colder body, they emit heat, increase their density and move in the opposite direction, thus forming a cycle of convection.

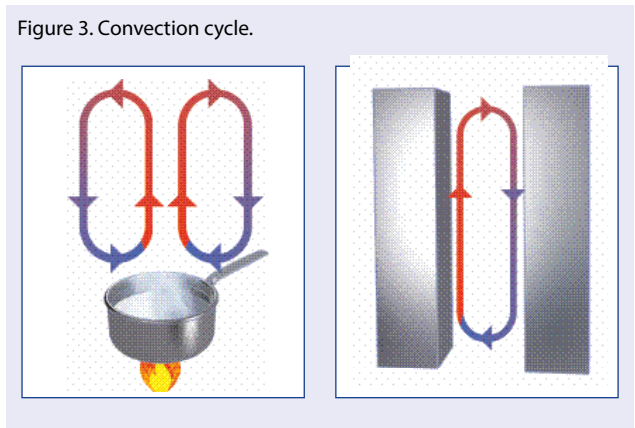

There are two types of convection – free or natural convection and forced convection.

**Natural convection:** the driving force comes from the variation of density in the fluid as a result of contact with a surface at different temperature, which then creates rising forces. The fluid near the surface acquires a velocity only because of this density difference, without any influence of external driving force. One example would be the transfer of heat to the outside from the wall or roof of a house on a sunny day without wind, or convection in a tank containing a stagnant liquid in which a heat resistor is submerged.

**Forced convection:** occurs when an external driving force moves a fluid over a surface that has a temperature that is higher or lower than that of the fluid. That external driving force can be a fan, a pump, the wind, etc. Since the velocity of the fluid in forced convection is higher than in natural convection, a greater amount of heat is transferred for a given temperature.

Figure 4. Types of convection

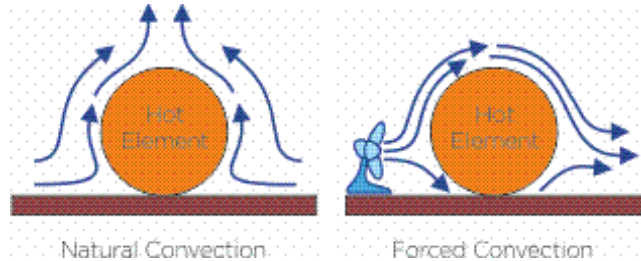

Although convection is quite complex, it should be noted that the heat transfer speed is proportional to the temperature difference and, therefore, the difference in temperature depends on the speed at which the fluid dissipates the heat.

To express the global effect of convection, **Newton's Law of Cooling** is used:

$$[2.3] \quad q = h (T_s - T_\infty)$$

where:

- q heat flow density. (W/m<sup>2</sup>)
- h heat transfer by convection coefficient (W/m<sup>2</sup>·K)
- T<sub>s</sub> surface temperature (K)
- T<sub>∞</sub> temperature away from the surface (K)

The coefficient of heat transfer by convection is not an intrinsic property of the fluid. It is a parameter that is determined experimentally and whose value depends on all the variables that influence convection, such as the surface geometry, the nature of the movement of the fluid, its properties and its speed. The typical values of h are given in the table.

Table 1. Typical values of the coefficient of heat transfer by convection

Type of convection	h (W/m <sup>2</sup> K)
Free convection of gas	2 - 25
Free convection of liquid	10 - 1,000
Forced convection of gas	25 - 250
Forced convection of liquid	50 - 20,000
Boiling and condensation	2,500 - 100,000

**Note:** On the surface, the temperature of the fluid is equal to that of the solid.

### 1.2.3. By radiation

Radiation is formed by electromagnetic waves of different lengths. While the two previous forms of transmission (conduction and convection) need a material support (a medium), radiation transmission can occur in vacuum conditions.

Figure 5. Conduction by radiation

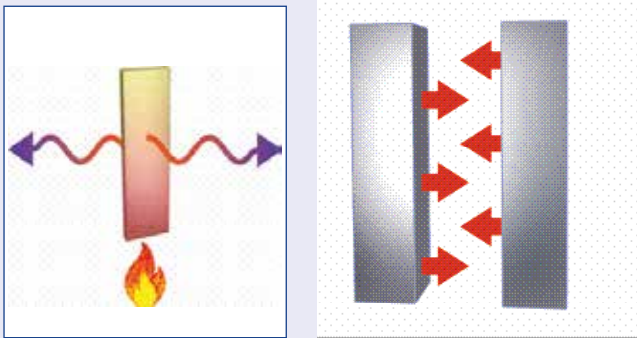

All bodies, even at low temperatures, emit heat by radiation and the amount of heat radiated increases when the body temperature rises.

$$[2.4] \quad h_r = a_r \cdot C_r$$

where:

$h_r$  heat transfer by radiation coefficient (W/m<sup>2</sup>·K)

$a_r$  temperature factor (K<sup>3</sup>)

$C_r$  surface radiation coefficient (W/m<sup>2</sup>K<sup>4</sup>)

When a body is in the presence of a hotter one, it absorbs more energy than it emits and vice versa, the amount transmitted being the difference between that emitted by both.

The transfer of heat by radiation to a surface, or from it, surrounded by a gas such as air, occurs simultaneously with the conduction (or convection if there is massive gas movement) between that surface and the gas. Therefore, the total heat transfer is determined by adding the contributions of the two transfer mechanisms. For simplicity and convenience, this is often done by defining a combined heat transfer coefficient,  $h$  combined, which includes the effects of both convection and radiation.

It must be borne in mind that radiation is usually significant in relation to conduction or natural convection, but negligible in relation to forced convection.

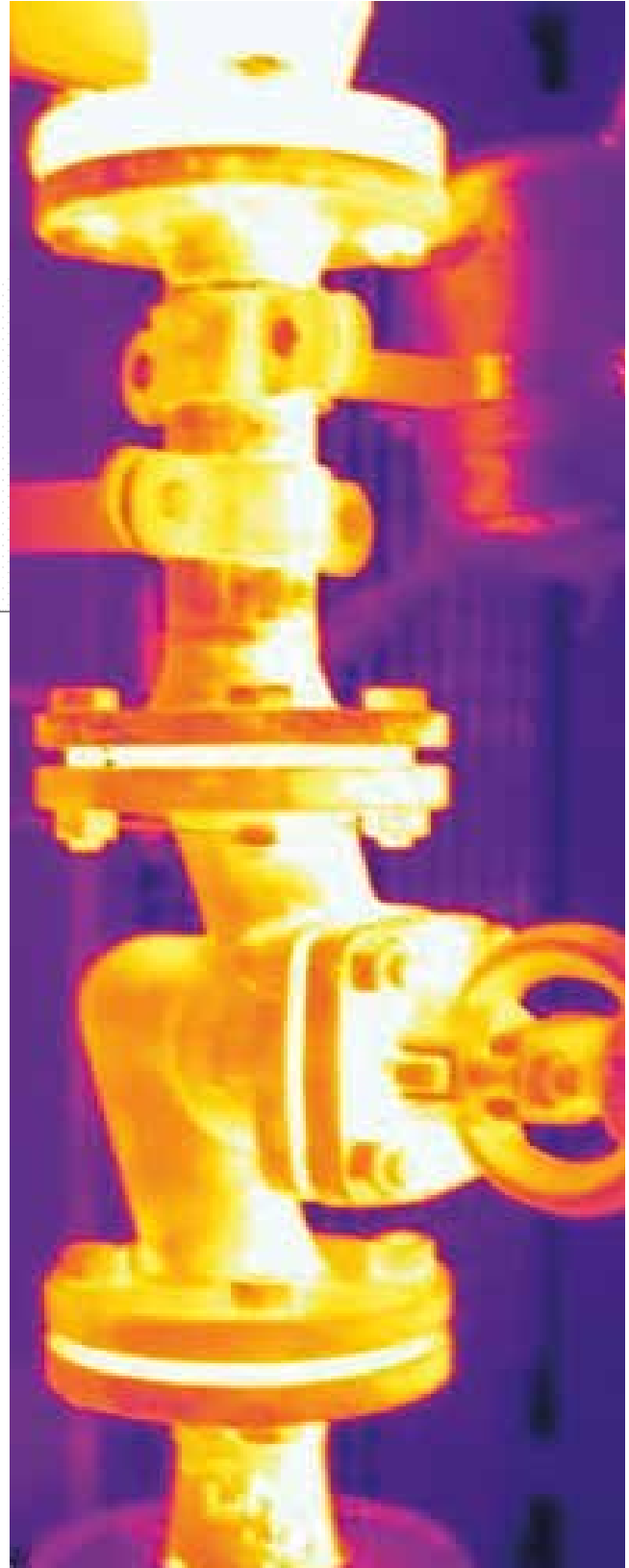

### 1.3. Surface heat transmission

In the installations, the surfaces maintain a heat transfer with the fluid in contact, where the convective and radioactive forms are mixed, especially when the fluid medium is ambient air.

Therefore, the joint study of both types of transfers is necessary.

The surface heat transfer coefficient is defined by the amount of heat flow that passes through a surface at a steady state, divided by the temperature difference between that surface and its surroundings, and is represented by  $h$ .

In the case of installations, there are two types of surface coefficient depending on whether it is the inner side  $h_i$  or the outer side  $h_e$ .

In general, the heat transfer surface coefficient,  $h_{sup}$ , is given by:

$$[2.5] \quad h_{sup} = h_{cv} + h_r$$

where:

$h_{cv}$ , convective part of the heat transfer surface coefficient.  
 $h_r$ , radiative part of the heat transfer surface coefficient.

#### 1.3.1. Convective part of the surface coefficient, $h_{cv}$

The surface heat transfer coefficient,  $h_{cv}$ , depends on several factors, such as air velocity, surface orientation, material type, temperature difference, etc.

In the convective part, a distinction must be made between the coefficient inside buildings and the coefficient outside them.

It must be borne in mind that, for pipes and tanks, there is a difference between the internal coefficient,  $h_i$  and the external coefficient,  $h_e$ .

#### a) Inside buildings

Inside buildings,  $h_{cv}$  can be calculated for vertical flat walls and vertical pipes for:

- *Free laminar flow* ( $H3 \cdot T < 10 \text{ m}^3 \cdot \text{K}$ )

$$[2.6] \quad h_{cv} = 1.32^4 \sqrt{\frac{\Delta T}{H}} = 1.32^4 \sqrt{\frac{T_{se} - T_a}{H}}$$

where:

$h_{cv}$  heat transfer by convection coefficient (W/m<sup>2</sup> K)  
 $T_{se}$  surface temperature of the wall (K)  
 $T_a$  temperature of the ambient air inside the building (K)  
 $H$  height of the wall or diameter of the pipe (m)

For vertical walls, vertical pipes and close to large spheres inside buildings, the convective part,  $h_{cv}$ , for:

- *Turbulent laminar flow* ( $H3 \cdot T \geq 10 \text{ m}^3 \cdot \text{K}$ )

$$[2.7] \quad h_{cv} = 1.74^3 \sqrt{\Delta T} = 1.74^3 \sqrt{T_{se} - T_a}$$

where:

$h_{cv}$  heat transfer by convection coefficient (W/m<sup>2</sup> K)  
 $T_{se}$  surface temperature of the wall (K)  
 $T_a$  temperature of the ambient air inside the building (K)  
 $H$  height of the wall or diameter of the pipe (m)

For horizontal pipes inside buildings, the  $h_{cv}$  is given by:

- *Laminar flow* ( $D_e3 \cdot T \leq 10 \text{ m}^3 \cdot \text{K}$ )

$$[2.8] \quad h_{cv} = 1.25^4 \frac{\sqrt{\Delta T}}{\sqrt{D_e}} = 1.25^4 \frac{\sqrt{T_{se} - T_a}}{\sqrt{D_e}}$$

where:

$h_{cv}$  heat transfer by convection coefficient (W/m<sup>2</sup> K)  
 $T_{se}$  surface temperature of the wall (K)  
 $T_a$  temperature of the ambient air inside the building (K)  
 $D_e$  exterior insulation diameter (m)

- *Turbulent flow* ( $D_e3 \cdot T > 10 \text{ m}^3 \cdot \text{K}$ )

$$[2.9] \quad h_{cv} = 1.21^3 \sqrt{\Delta T} = 1.21^3 \sqrt{T_{se} - T_a}$$

where:

$h_{cv}$  heat transfer by convection coefficient (W/m<sup>2</sup> K)  
 $T_{se}$  surface temperature of the wall (K)  
 $T_a$  temperature of the ambient air inside the building (K)

In practice, this coefficient is not important for flat horizontal surfaces inside buildings.

All the equations of the convective part of the heat coefficient of the "external surface" of a wall inside buildings apply to situations with temperature differences of less than 100 °C between surface and air.

**NOTE:** For cylindrical ducts with a diameter smaller than 0.25 m, a good approximation of the convective part of the external coefficient can be calculated by means of equation [2.8]. For larger diameters, of > 0.25 m, equation [2.6] can be used. The respective accuracy is 5 % for diameters greater than 0.4 m and 10 % for diameters  $0.25 < D_e < 0.4$  m. Equation [2.6] is also used for ducts with a rectangular section, and with a width and height of similar magnitude.

#### b) Outside buildings

For vertical flat walls on the outside of buildings and close to large spheres, the convective part,  $h_{cv}$ , of the surface coefficient is given by:

- *Laminar flow* ( $v \cdot H < 8 \text{ m}^2/\text{s}$ )

$$[2.10] \quad h_{cv} = 3.96 \sqrt{\frac{v}{H}}$$

where:

$h_{cv}$  heat transfer by convection coefficient (W/m<sup>2</sup> K)

$v$  wind velocity (m/s)

$H$  height of the wall or diameter of the pipe (m)

- *Turbulent flow* ( $v \cdot H > 8 \text{ m}^2/\text{s}$ )

$$[2.11] \quad h_{cv} = 5.76 \sqrt[5]{\frac{v^4}{H}}$$

where:

$h_{cv}$  heat transfer by convection coefficient (W/m<sup>2</sup> K)

$v$  wind velocity (m/s)

$H$  height of the wall or diameter of the pipe (m)

For horizontal and vertical pipes that are outside buildings, the following expressions apply:

- *Laminar flow* ( $v \cdot D_e \leq 8.55 \text{ m}^2/\text{s}$ )

$$[2.12] \quad h_{cv} = \frac{8.1 \cdot 10^{-3}}{D_e} + 3.14 \sqrt{\frac{v}{H}}$$

where:

$h_{cv}$  heat transfer by convection coefficient (W/m<sup>2</sup> K)

$v$  wind velocity (m/s)

$H$  height of the wall or diameter of the pipe (m)

$D_e$  exterior insulation diameter (m)

- *Turbulent flow* ( $v \cdot D_e > 8.55 \text{ m}^2/\text{s}$ )

$$[2.13] \quad h_{cv} = 8.9 \frac{v^{0.9}}{D_e^{0.1}}$$

where:

$v$  wind velocity (m/s)

$D_e$  exterior insulation diameter (m)

#### Note:

- To calculate the surface temperature, expressions [2.6] and [2.7] should be used for the wall and the pipe instead of formulas [2.10] and [2.13] when there is no air present.
- For horizontal surfaces on the outside, equation [2.10] applies to laminar flow, and [2.11] to turbulent flow.

## Summary

Table 2. Summary of the connective part of the surface coefficient,  $h_{cv}$

<b><math>h_{cv}</math></b>	<b>Inside buildings</b>	<b>Free laminar flow</b>	Vertical flat walls and vertical pipes	$h_{cv} = 1.32 \sqrt[4]{\frac{\Delta T}{H}} = 1.32 \sqrt[4]{\frac{T_{se} - T_a}{H}}$	<b><math>h_{cv}</math></b> Surface coefficient (W/m <sup>2</sup> K) <b><math>T_{se}</math></b> Surface temperature of the wall (K) <b><math>T_a</math></b> Ambient temperature inside the building (K) <b><math>H</math></b> Height of the wall or diameter of the pipe (m)
				Equation [2.6]	
			Horizontal pipes	$h_{cv} = 1.25 \sqrt[4]{\frac{\Delta T}{D_e}} = 1.25 \sqrt[4]{\frac{T_{se} - T_a}{D_e}}$	<b><math>h_{cv}</math></b> Surface coefficient (W/m <sup>2</sup> K) <b><math>T_{se}</math></b> Surface temperature of the wall (K) <b><math>T_a</math></b> Ambient temperature inside the building (K) <b><math>D_e</math></b> Exterior diameter of the insulation (m)
			Equation [2.7]		
		<b>Free turbulent flow</b>	Vertical walls, vertical pipes and large spheres	$h_{cv} = 1.74 \sqrt[3]{\Delta T} = 1.74 \sqrt[3]{T_{se} - T_a}$	<b><math>h_{cv}</math></b> Surface coefficient (W/m <sup>2</sup> K) <b><math>T_{se}</math></b> Surface temperature of the wall (K) <b><math>T_a</math></b> Ambient temperature inside the building (K)
				Equation [2.8]	
	Horizontal pipes		$h_{cv} = 1.21 \sqrt[3]{\Delta T} = 1.21 \sqrt[3]{T_{se} - T_a}$	<b><math>h_{cv}</math></b> Surface coefficient (W/m <sup>2</sup> K) <b><math>T_{se}</math></b> Surface temperature of the wall (K) <b><math>T_a</math></b> Ambient temperature inside the building (K)	
		Equation [2.9]			
	<b>Outside buildings</b>	<b>Laminar flow</b>	Vertical walls and large spheres	$h_{cv} = 3.96 \sqrt{\frac{v}{H}}$	<b><math>h_{cv}</math></b> Surface coefficient (W/m <sup>2</sup> K) <b><math>v</math></b> Wind velocity (m/s) <b><math>H</math></b> Height of the wall or diameter of the pipe (m)
				Equation [2.10]	
		Horizontal and vertical pipes	$h_{cv} = \frac{8.1 \cdot 10^{-3}}{D_e} + 3.14 \sqrt{\frac{v}{H}}$	<b><math>h_{cv}</math></b> Surface coefficient (W/m <sup>2</sup> K) <b><math>v</math></b> Wind velocity (m/s) Height of the wall or diameter of the pipe (m) <b><math>D_e</math></b> Exterior diameter of the insulation (m)	
		Equation [2.11]			
<b>Turbulent flow</b>		Vertical walls and large spheres	$h_{cv} = 5.76 \sqrt[4]{\frac{v^3}{H}}$	<b><math>h_{cv}</math></b> Surface coefficient (W/m <sup>2</sup> K) <b><math>v</math></b> Wind velocity (m/s) <b><math>H</math></b> Height of the wall or diameter of the pipe (m)	
			Equation [2.12]		
	Horizontal and vertical pipes	$h_{cv} = 8.9 \frac{v^{0.9}}{D_e^{0.1}}$	<b><math>h_{cv}</math></b> Surface coefficient (W/m <sup>2</sup> K) <b><math>v</math></b> Wind velocity (m/s) <b><math>D_e</math></b> Exterior diameter of the insulation (m)		
	Equation [2.13]				

**1.3.2. Radiative part of the surface coefficient,  $h_r$**

The surface coefficient due to radiation,  $h_r$ , is a function of the temperature, the surface finish of the material and its emissivity. The surface coefficient due to radiation is defined by:

$$[2.14] \quad h_r = a_r \cdot C_r$$

where:

$h_r$  radiative part surface coefficient (W/m<sup>2</sup> K)

$a_r$  temperature factor (k<sup>3</sup>), given by the following expression:

$$[2.15] \quad a_r = \frac{T_1^4 - T_2^4}{T_1 - T_2}$$

which can be approximated up to a temperature difference of 200K by:

$$[2.16] \quad a_r \approx 4 \cdot (T_{av})^3$$

where  $T_{av} = 0.5 \cdot (T_{surface} + T_{ambient})$  (surface temperature + ambient temperature or surface of a nearby radiating surface) (K).

$C_r$  surface radiation coefficient (W/m<sup>2</sup> K<sup>4</sup>), given by the expression:

$$[2.17] \quad C_r = \epsilon \cdot \sigma$$

Emissivity, (dimensionless)

Constant radiation coefficient of the black body W/(m<sup>2</sup> ·K<sup>4</sup>), whose value is:

$$\Sigma = 5.67 \cdot 10^{-8}$$

Surface		$C_r$ W/(m <sup>2</sup> · K <sup>4</sup> )
Aluminum. bright rolled	0.05	$0.28 \cdot 10^{-8}$
Aluminium. oxidized	0.13	$0.74 \cdot 10^{-8}$
Galvanized sheet metal. blank	0.26	$1.47 \cdot 10^{-8}$
Galvanized sheet metal. dusty	0.44	$2.49 \cdot 10^{-8}$
Austenitic sheet	0.15	$0.85 \cdot 10^{-8}$
Aluminium-zinc sheet	0.18	$1.02 \cdot 10^{-8}$
Non-metallic surfaces	0.94	$5.33 \cdot 10^{-8}$

**1.3.3. Approximation for calculating the inner surface coefficient of heat transfer ( $h_i$ )**

The inner surface coefficient of heat transfer  $h_i$  is the result of adding the inner radiative part ( $h_{ri}$ ) and the inner convective part ( $h_{cvi}$ ):

$$[2.18] \quad h_i = h_{ri} + h_{cvi}$$

Bearing in mind that  $h_{cvi}$  is calculated as:

$$[2.19] \quad h_{cvi} = 0.04 Pe^{0.75} \lambda / D$$

where:

$$Pe = v Lo \rho Cp / \lambda$$

$v$  average speed (m/s)

$Lo$  equivalent length (m) - corresponds to the radius in the case of horizontal pipes, and length in the case of vertical pipes

average density (kg/m<sup>3</sup>)

$Cp$  average specific heat (J/(kgK))

$D$  interior insulation diameter (m)

It must be remembered that the inside surface coefficient of heat transfer  $h_i$  tends to infinity in the case of liquids (and, therefore, the inner surface thermal resistance tends to 0 ( $Ri = 1/h_i$ )), thus being negligible. However, the value of  $h_i$  in the case of gases, where its value does not tend to infinity even though it is high, must be taken into account for calculations.

**1.3.4. Approximation for calculating the outer surface coefficient of heat transfer ( $h_e$ )**

An approximation of the outer surface coefficient of heat transfer ( $h_e$ ) can be made by using the coefficients of the table in the following equations:

• For horizontal pipes ( $0.25 \text{ m} < D < 1 \text{ m}$ ):

$$[2.20] \quad h = h_e = C_H + 0.5 \Delta T \text{ W}/(\text{m}^2 \cdot \text{K})$$

• For vertical pipes and walls:

$$h = h_e = C_V + 0.09 \Delta T \text{ W}/(\text{m}^2 \cdot \text{K})$$

[2.21]

Using the coefficients of the following table:

Table 3. Values of coefficients  $C_H$  and  $C_V$  for approximately calculating the surface heat coefficient.

Surface	$C_H$	$C_V$
Aluminium. bright rolled	2.5	2.7
Aluminium. oxidized	3.1	3.3
Galvanized sheet metal. blank	4.0	4.2
Galvanized sheet metal. dusty	5.3	5.5
Austenitic sheet	3.2	3.4
Aluminium-zinc sheet	3.4	3.6
Non-metallic surfaces	8.5	8.7

## 1.4. Heat transfer by conduction in steady state

### 1.4.1. In flat walls

#### a) Single layer

The simplest case of conduction is that which occurs in solids of parallel faces so that the flow is unidirectional. When this solid is in thermodynamic equilibrium without changing its temperature over time, which is called the stationary state, it is implied that heat is neither accumulated nor generated.

The heat transfer in a certain direction is driven by its temperature gradient (temperature difference) in that direction. The measurements of temperature at various points on the interior or exterior surface of the wall will confirm that a wall's surface is almost isothermal. That is, the temperature at the top and bottom of a wall's surface, and also at the right and left ends, is theoretically the same, there being no heat transfer.

On the contrary, if the temperature difference between the inner and outer surface of this wall is taken into account, therefore, the significant heat transfer is in the direction of the inner surface towards the outside.

Figure 6. The flow of heat through a wall is one-dimensional when the temperature only varies in one direction.

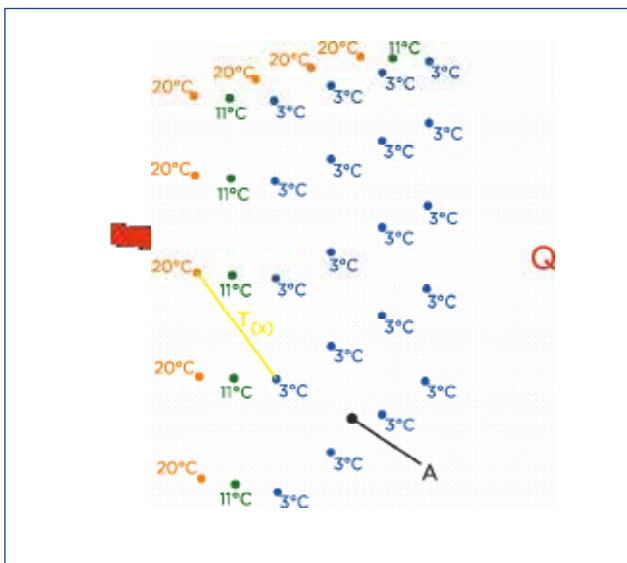

Considering a one-dimensional steady-state condition of heat through a flat wall of thickness  $d$ , the temperature difference from one side of the wall  $T = T_2 - T_1$ , is constant. The speed of heat transfer,  $q$  and  $\frac{\Delta T}{(\Delta x)}$  (temperature gradient), will also be constant  $(\frac{\Delta T}{\Delta x})$ . This means that the temperature through the wall varies linearly with  $x$ ; that is, the temperature distribution in the wall, under stationary conditions, is a straight line (Figure 7).

Figure 7. Representation of a flat wall of thickness  $d$  constituted by a material of constant thermal conductivity  $\lambda$ .

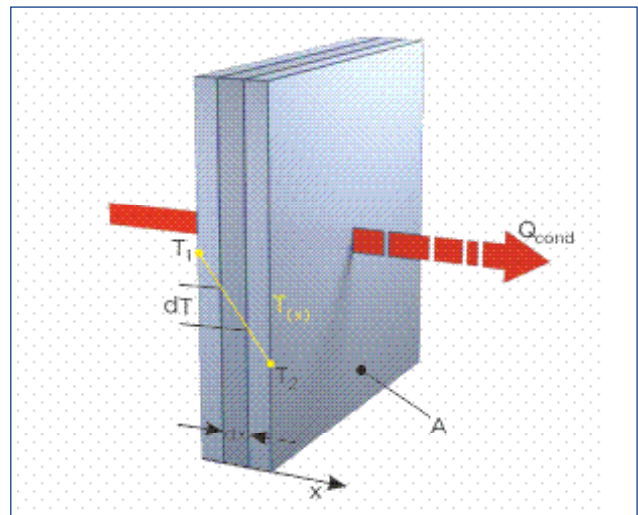

The speed of the heat transfer  $q$ , through the wall, doubles when the temperature difference  $T$  is doubled from one side of the wall to the other, reducing by half when the thickness  $d$  of the wall is doubled.

In conclusion, it is determined that the speed of heat conduction through a flat layer is proportional to the temperature difference, but is inversely proportional to the thickness of the layer.

The concept of thermal resistance is used in order to determine the density of heat flow in a steady state through the wall, obtained by dividing the difference in temperature in the wall surfaces between the thermal resistance. This equation expresses *Fourier's Law of Heat Conduction for a flat wall*:

"The speed of heat conduction,  $q$ , through a flat wall is proportional to the average thermal conductivity, to the area of the wall and to the temperature difference, but is inversely proportional to the thickness of the wall".

[2.22]

$$q = \frac{T_{si} - T_{se}}{R_{wall}}$$

where:

$q$  density of heat flow (W/m<sup>2</sup>)

$T_{si}$  internal surface temperature (K)

$T_{se}$  external surface temperature (K)

$R$  thermal resistance of a flat wall (m<sup>2</sup>K/W), expressed as:

[2.23]

$$R_{wall} = \frac{d}{\lambda}$$

where:

$d$  layer thickness (m)

$\lambda$  thermal conductivity of the material (W/m·K)

## EXAMPLE 1: HEAT LOSS THROUGH A WALL

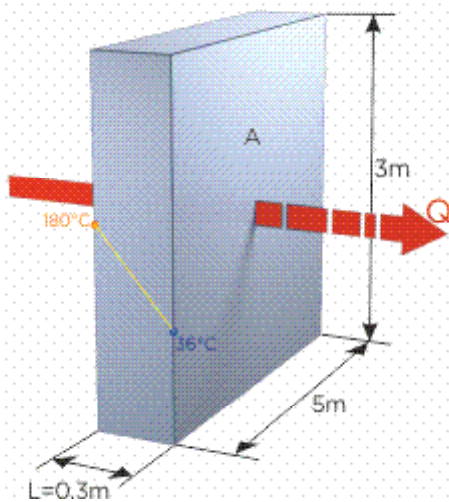

A tank wall 3 m high, 5 m wide and 0.30 m thick with a thermal conductivity of  $\lambda = 0.90 \text{ W/m}\cdot\text{K}$  is considered. The temperatures of the inner and outer surfaces that were measured were found to be 180 °C (453 K) and 36 °C (309 K), respectively. Determine the heat loss through the wall on that day.

### SOLUTION

1. The two surfaces of the wall are kept at the specified temperatures.
2. The heat transfer through the wall is stable, since the surface temperatures remain constant at the specified values.
3. The heat transfer is one-dimensional, since any significant temperature gradients will exist in the direction from the inside to the outside.
4. The thermal conductivity is constant.

The steady-state flow density can be calculated using the concept of thermal resistance, from equation [2.23]:

$$q = \frac{T_{si} - T_{se}}{R_{wall}} \rightarrow R_{wall} = \frac{d}{\lambda} = \frac{0.30}{0.90} = 0.333 \text{ K}\cdot\text{m}^2/\text{W}$$

Substituting in equation [2.22],

$$q = \frac{T_{si} - T_{se}}{R_{wall}} = \frac{(453 - 309)}{0.333} = 432 \text{ W/m}^2$$

**b) Multi-layer wall**

We consider, in a stationary and one-dimensional state, a flat wall consisting of several layers of materials of different thicknesses, thermal conductivities and known temperatures. The following figure represents a multi-layer flat wall:

Figure 8. Distribution of temperature in a flat multi-layer wall

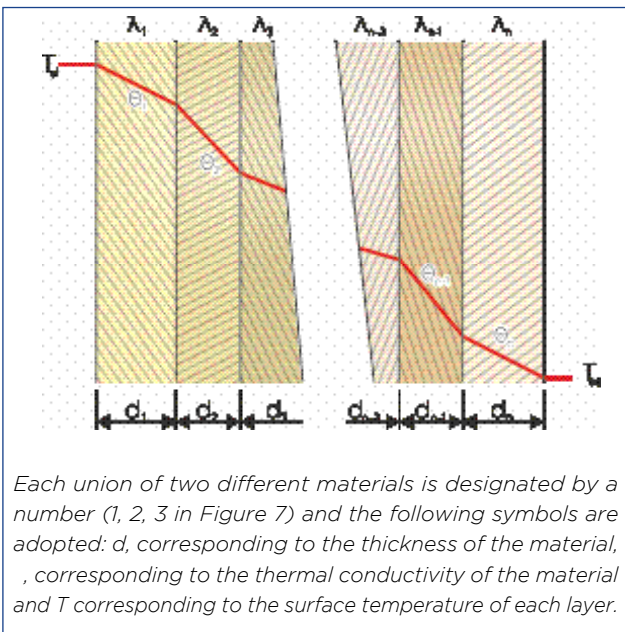

The concept of thermal resistance is used in order to determine the density of heat flow in a steady state through the multi-layer wall, obtained by dividing the difference in temperature in the two surfaces by the known temperatures between the total thermal resistance in both of them:

$$[2.24] \quad q = \frac{(T_{si} - T_{se})}{R'}$$

where:

- $q$  density of heat flow in multi-layer flat wall (W/m<sup>2</sup>)
- $T_{si}$  temperature of the internal surface (K)
- $T_{se}$  temperature of the external surface (K)
- $R'$  thermal resistance of multi-layer flat wall (m<sup>2</sup>K/W), its expression being:

$$[2.25] \quad R' = \sum_{j=1}^n \frac{d_j}{\lambda_j}$$

where:

- $d_j$  thickness of each layer (m)
- $\lambda_j$  thermal conductivity of the material of each layer (W/m·K)

The term thermal resistance is limited to the systems through which the speed of heat transfer ( $q$ ) remains constant, that is, to systems involving stable heat transfer, without generating heat within the medium.

**EXAMPLE 2: HEAT LOSS THROUGH A MULTI-LAYER WALL**

Taking EXAMPLE 1: A wall 3 m high, 5 m wide and 0.30 m thick has a thermal conductivity of  $\lambda = 0.90$  W/m·K. This wall has glass wool insulation (TECH Slab 3.0) of 80 mm thickness and  $\lambda_{108^\circ\text{C}} = 0.049$  W/m·K of thermal conductivity. The temperatures of the inner and outer surfaces that were measured were found to be 180 °C (453 K) and 36 °C (309 K), respectively. Determine the heat loss through the wall on that day.

**SOLUTION**

1. The two surfaces of the wall are kept at the specified temperatures.
2. The heat transfer through the wall is stable. It is necessary to take the conductivity value at the average temperature; in this case it would be:

$$\lambda_m = \frac{1}{T_o - T_i} \cdot \int_{T_i}^{T_o} \lambda(T) dT = 0.049 \text{ W/mK}$$

Taking into account the previous points and given that:

Parameters	Layer 1	Layer 2
Thickness (m)	0.30	0.08
Thermal conductivity (W/mk)	0.90	0.049

In this case, the heat loss through the wall is determined using the concept of thermal resistance for a multi-layer wall:

$$q = \frac{T_{si} - T_{se}}{R'}$$

The thermal resistance ( $R'$ ) being equation [2.25]:

$$R_{\text{wall}} = \sum_{j=1}^n \frac{d_j}{\lambda_j} = \frac{0,3\text{m}}{(0,9\text{W/mK})} + \frac{0,08\text{m}}{(0,049\text{W/mK})} = 1,97\text{m}^2\text{K/W}$$

Therefore, the heat loss from the wall will be:

$$q = \frac{T_{si} - T_{se}}{R'} = \frac{(453 - 309)\text{K}}{1,97\text{m}^2\text{K/W}} = 73,096\text{W/m}^2$$

**As we can see, putting insulation in the wall, thus forming a multi-layer wall, gives us significantly lower heat losses than in EXAMPLE 1 ( $q=432$  W/m<sup>2</sup>)**

**Thermal resistance to convection and radiation for flat walls**

**• The concept of thermal resistance**

As mentioned previously, the equation that expresses Fourier’s Law of Heat Conduction for a flat wall is:

$$[2.26] \quad \frac{T_{si} - T_{se}}{R_{wall}} \text{ (W)}$$

where:

- q heat flow of flat wall (W/m<sup>2</sup>)
- T<sub>si</sub> internal surface temperature (K)
- T<sub>se</sub> external surface temperature (K)
- R<sub>wall</sub> thermal resistance to conduction of the wall (m<sup>2</sup>K/W), expressed as:

$$[2.27] \quad R_{wall} = \frac{d}{\lambda}$$

where:

- d layer thickness (m)
- λ thermal conductivity of the material (W/m·K)

The thermal resistance of a medium depends on the geometrical configuration and the thermal properties of the medium.

The equation given above for the heat flow is analogous to the ratio for the flow of electric current I.

Figure 9. Analogy between the concepts of thermal and electrical resistance.

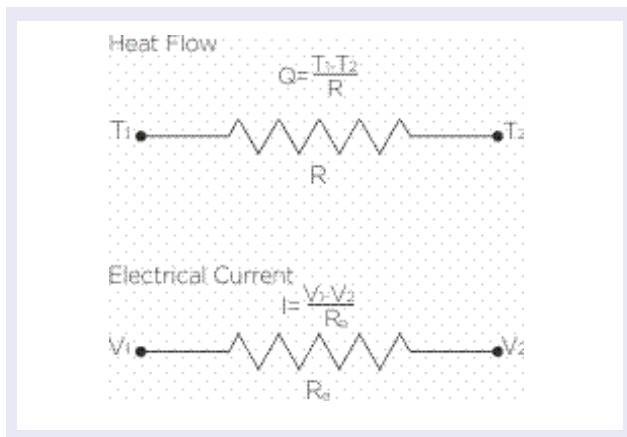

where:

- Re electrical thermal resistance (Re = L / λ)
- V<sub>1</sub>-V<sub>2</sub> difference of cross-potential of the resistance.

We make the analogy of the heat flow through a layer corresponding to the electric current, the thermal resistance to the electrical resistance and the difference of temperature to the voltage difference (Figure 9).

When considering the heat transfer by convection of the solid surface temperature T<sub>s</sub> to a fluid whose temperature at a point sufficiently far from the surface is T<sub>∞</sub>, with a heat transfer by convection coefficient h, Newton’s law of cooling for the heat flow by convection, q=h<sub>cv</sub>(T<sub>s</sub> - T<sub>∞</sub>), can be simplified to obtain

$$[2.28] \quad q = \frac{T_s - T_{\infty}}{R_{cv}} \text{ (W/m}^2\text{)}$$

Figure 10. Scheme for resistance to convection on a surface.

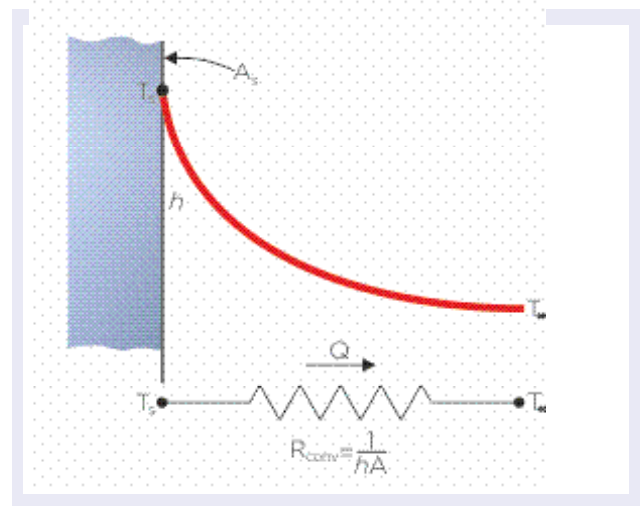

where:

- q density of heat flow by convection (W/m<sup>2</sup>)
- T<sub>s</sub> surface temperature (K)
- T<sub>∞</sub> temperature away from the surface (K)
- R<sub>cv</sub> thermal resistance to convection (m<sup>2</sup>K/W), expressed as:

$$[2.29] \quad R_{cv} = \frac{1}{h_{cv}}$$

where:

- h<sub>cv</sub> heat transfer by convection coefficient (W/m<sup>2</sup> k)

When the heat transfer by convection coefficient is very large (h→∞), the resistance to convection becomes zero and T<sub>s</sub> ffi T<sub>∞</sub> that is, the surface does not offer resistance to the convection and therefore does not decelerate the heat transfer process. This occurs on surfaces where boiling and condensation occur, and the surface does not need to be flat for this.

When the wall is surrounded by a fluid gas, such as air, the effects of radiation that have so far been ignored can be significant and must be considered. The heat transfer by radiation is expressed as

$$q = \epsilon \sigma (T_s^4 - T_{\infty}^4) + h_{rad} (T_s - T_{alred}) = \frac{T_s - T_{alred}}{R_{rad}}$$

[2.30]

where:

- q heat flow by radiation of the flat wall (W/m<sup>2</sup>)
- $\epsilon$  Emissivity, (dimensionless)
- T<sub>s</sub> surface temperature (K)
- T<sub>alred</sub> average temperature of surrounding surfaces (K)
- h<sub>rad</sub> heat transfer by radiation coefficient (W/m<sup>2</sup> K),
- R<sub>rad</sub> thermal resistance to radiation (m<sup>2</sup>K/W), expressed as:

$$R_{rad} = \frac{1}{h_{rad}}$$

[2.31]

For a surface exposed to the surrounding air, convection and radiation apply simultaneously and the total heat transfer on the surface is determined by adding (or subtracting if they have opposite directions) the components of radiation and convection. The resistance to convection and radiation are parallel to each other, as shown in Figure 11, and can cause some complications in the thermal resistance network. When T<sub>alred</sub> = T<sub>∞</sub>, the radiation effect can be properly taken into account by replacing h in the convection resistance ratio by

$$h_{sup} = h_{cv} + h_{rad}$$

[2.5]

Denominating this resistance, in other words, surface thermal resistance, which includes the effects of convection and radiation:

$$R_{sup} = \frac{1}{h_{sup}}$$

where:

- h<sub>cv</sub>, surface coefficient of heat transfer by conduction. (W/m<sup>2</sup> K),
- h<sub>r</sub>, heat transfer by radiation surface coefficient (W/m<sup>2</sup> K),

Figure 11. Scheme for resistance to convection and radiation on a surface.

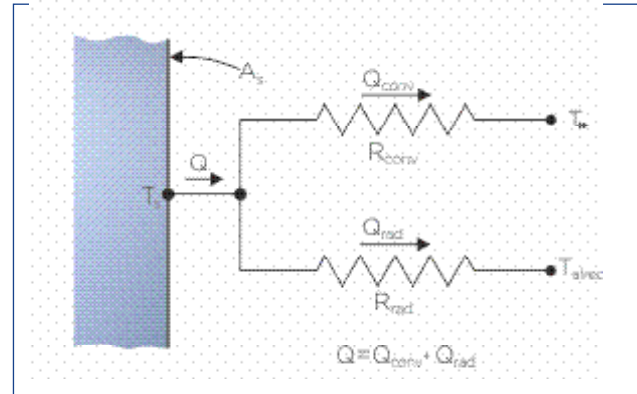

• Network of thermal resistors for a flat wall

We consider the one-dimensional heat flow in a steady state through a flat wall of thickness d and thermal conductivity  $\lambda$ , which is exposed to convection and radiation on both sides at temperatures T<sub>∞1</sub> and T<sub>∞2</sub>. Assuming that T<sub>∞1</sub> > T<sub>∞2</sub> the temperature variation is that which is shown in Figure 12. The temperature varies linearly in the wall and tends asymptotically to T<sub>∞1</sub> and T<sub>∞2</sub> in the fluids, as it moves away from the wall.

Figure 12. Network of thermal resistors for transferring heat through a flat wall subject to convection on both sides and the electrical analogy.

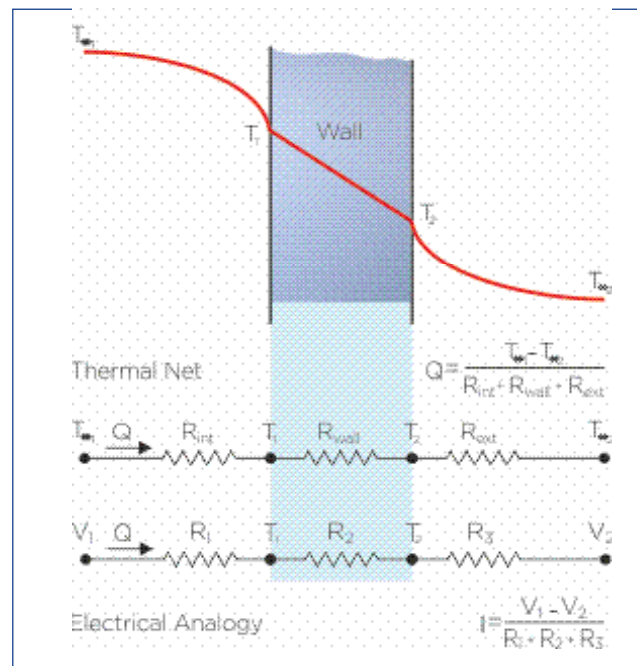



$$[2.32] \quad q = h_{sup,i}(T_{\infty 1} - T_1) = \lambda \frac{T_1 - T_2}{d} = h_{sup,e}(T_2 - T_{\infty 2})$$



$$[2.33] \quad q = \frac{T_{\infty 1} - T_1}{1/h_{sup,i}} = \frac{T_1 - T_2}{d/\lambda} = \frac{T_2 - T_{\infty 2}}{1/h_{sup,e}}$$

$$= \frac{T_{\infty 1} - T_1}{R_{sup,i}} = \frac{T_1 - T_2}{R_{wall}} = \frac{T_2 - T_{\infty 2}}{R_{sup,e}}$$

Therefore, for a surface exposed to convection and to radiation for flat walls, the heat flow density would be:

$$[2.34] \quad q = \frac{T_{\infty 1} - T_{\infty 2}}{R_{total}}$$

where:

$$[2.35] \quad R_{total} = R_{sup,i} + R_{wall} + R_{sup,e} = \frac{1}{h_{sup,i}} + \frac{d}{\lambda} + \frac{1}{h_{sup,e}}$$

where:

- q heat flow of flat wall (W/m<sup>2</sup>)
- T<sub>1</sub> temperature of the internal surface (K)
- T<sub>2</sub> temperature of the external surface (K)
- T<sub>∞1</sub> temperature away from the internal surface (K)
- T<sub>∞2</sub> temperature away from the external surface (K)
- h<sub>sup,i</sub> surface coefficient of heat transfer by convection including the effects of radiation, inner surface (W/m<sup>2</sup>·K)
- h<sub>sup,e</sub> surface coefficient of heat transfer by convection including the effects of radiation, outside surface (W/m<sup>2</sup>·K)
- R<sub>sup,i</sub> surface thermal resistance exposed to convection and radiation (K m<sup>2</sup>/W)
- R<sub>wall</sub> thermal resistance of flat wall (K m<sup>2</sup>/W)
- R<sub>total</sub> total thermal resistance of flat wall (K m<sup>2</sup>/W)

It must be taken into account that the thermal resistors are in series and the equivalent thermal resistance is calculated by adding each of the resistances, as in the electrical resistances connected in series.

*"The rapidity of the stationary heat transfer between two surfaces is equal to the temperature difference divided by the total thermal resistance between the two surfaces".*

## EXAMPLE 3: NETWORK OF THERMAL RESISTORS FOR A FLAT WALL

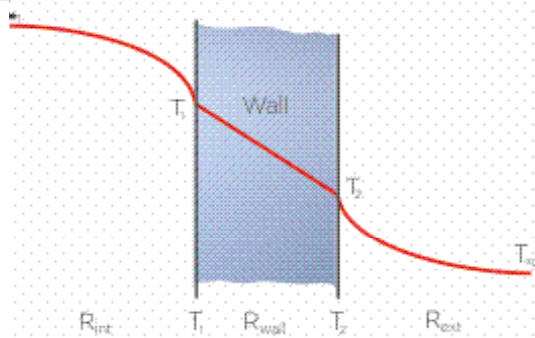

Taking EXAMPLE 1: A wall 0.30m thick has a thermal conductivity of  $\lambda = 0.9 \text{ W/m}\cdot\text{K}$ . The inside temperature is  $T_{\infty 1} = 180 \text{ }^\circ\text{C}$  (453 K) and the outside temperature turns out to be  $T_{\infty 2} = 36 \text{ }^\circ\text{C}$  (309 K). Determine the heat flow (steady state) through the wall, knowing that the heat transfer coefficients of the inner and outer surfaces are  $h_{\text{sup},i} = 17,2 \text{ W/m}^2\text{K}$  and  $h_{\text{surf},e} = 17.2 \text{ W/m}^2\text{K}$ , which include radiation.

## SOLUTION

1. The two surfaces of the wall are kept at the specified temperatures.
2. The heat transfer through the wall is stable, since the surface temperatures remain constant at the specified values.
3. The heat transfer is one-dimensional, since any significant temperature gradients will exist in the direction from the inside to the outside.
4. The thermal conductivity is constant

There is a problem related to conduction and convection in their surfaces through the wall, with the easiest way to solve it being the concept of thermal resistance as shown below based on equation [2.32]:

$$q = \frac{T_{\infty 1} - T_{\infty 2}}{R_{\text{total}}}$$

Since all the resistors are in series, the total resistance:

$$R_{\text{total}} = R_{\text{sup},1} + R_{\text{wall}} + R_{\text{sup},2} = \frac{1}{h_{\text{sup},1}} + \frac{d}{\lambda} + \frac{1}{h_{\text{sup},2}}$$

where:

$$R_{\text{sup},1} = \frac{1}{h_{\text{sup},1}} = \frac{1}{17.2 \text{ W/m}^2\text{K}} = 0.058 \text{ m}^2\text{K/W}$$

$$R_{\text{wall}} = \frac{d}{\lambda} = \frac{0.30 \text{ m}}{0.90 \text{ W/m}\cdot\text{K}} = 0.330 \text{ m}^2\text{K/W}$$

$$R_{\text{sup},2} = \frac{1}{h_{\text{sup},2}} = \frac{1}{17.2 \text{ W/m}^2\text{K}} = 0.058 \text{ m}^2\text{K/W}$$

$$R_T = R_{\text{sup},1} + R_{\text{wall}} + R_{\text{sup},2} = 0.058 + 0.330 + 0.058 = 0.446 \text{ m}^2\text{K/W}$$

Thus:

$$q_T = \frac{T_{\infty 1} - T_{\infty 2}}{R_T} = \frac{T_{\infty 1} - T_{\infty 2}}{R_{\text{sup},1} + R_{\text{wall}} + R_{\text{sup},2}} = \frac{(453 - 309)}{0.446} = 322,87 \text{ W/m}^2$$

As we can see, with this network of thermal resistors for a flat wall of a layer, when taking into account the surface coefficients, the heat transfer process of this wall is slowed down with respect to EXAMPLE 1 (432 W/m<sup>2</sup>), which is why there is less heat loss.

Figure 13. Network of thermal resistors for transferring heat through a flat wall of two layers with convection phenomenon on both sides

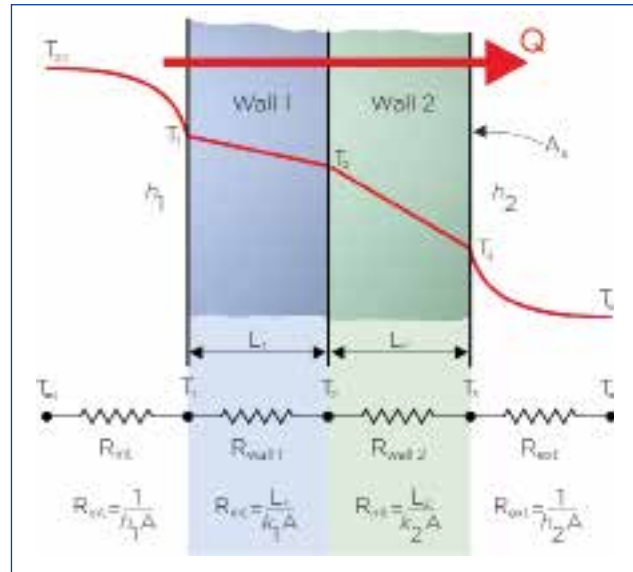

### • Network of thermal resistors for a multi-layer, flat wall

If we now consider a flat wall consisting of two layers, the rate of stationary heat transfer through this composite wall can be expressed as

$$[2.36] \quad q = \frac{T_{\infty 1} - T_{\infty 2}}{R'_{total}}$$

where:

$q$  heat flow of multi-layer flat wall (W/m<sup>2</sup>)

$T_{\infty 1}$  temperature away from the inner surface (K)

$T_{\infty 2}$  temperature away from the external surface (K)

$R'_{total}$  total thermal resistance of multi-layer flat wall (m<sup>2</sup>K/W), expressed as:

[2.37]

$$R'_{total} = R_{sup,1} + R_{wall,1} + R_{wall,2} + R_{sup,2} = \frac{1}{h_{sup,1}} + \frac{d_1}{\lambda_1} + \frac{d_2}{\lambda_2} + \frac{1}{h_{sup,2}}$$

where:

$R_{sup,n}$  thermal resistance exposed to convection and radiation (m<sup>2</sup>K/W)

$R_{wall,n}$  thermal resistance of flat wall (m<sup>2</sup>K/W)

$d_1$  thickness of layer 1 (m)

$d_2$  thickness of layer 2 (m)

thermal conductivity of the material (W/m·K)

The resistors are in series and therefore the total thermal resistance is simply the arithmetic sum of each of the thermal resistors found in the path of the heat flow.

This result is the same as in the case of a single layer, except that one more resistor is added for the additional layer.

The same development is valid for flat walls that have three or more layers when adding an additional resistor per additional layer, also considering in this case the surface resistance, which is the combination of heat transfer by convection and radiation coefficients.

To find  $T_1$ :

$$q = \frac{T_{\infty 1} - T_1}{R_{sup,1}}$$

To find  $T_2$ :

$$q = \frac{T_{\infty 1} - T_2}{R_{sup,1} + R_{wall,1}}$$

To find  $T_3$ :

$$q = \frac{T_3 - T_{\infty 2}}{R_{sup,2}}$$

where:

$T_1$  temperature of layer 1 (K)

$T_2$  temperature of layer 2 (K)

$T_3$  temperature of layer 3 (K)

$T_{\infty 1}$  temperature away from the internal surface (K)

$T_{\infty 2}$  temperature away from the external surface (K)

$R_{sup,n}$  thermal resistance exposed to convection and radiation (m<sup>2</sup>K/W)

EXAMPLE 4: NETWORK OF THERMAL RESISTORS FOR A MULTI-LAYER WALL

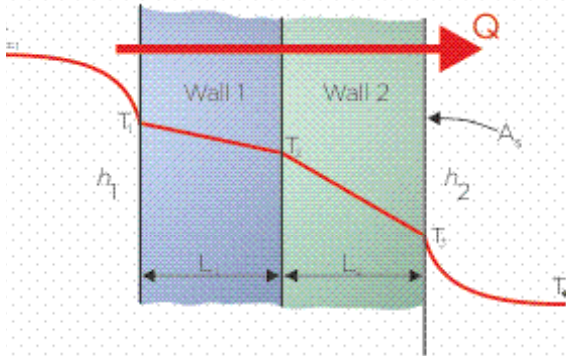

Taking EXAMPLE 2: A wall 3 m high, 5m wide and 0.30 m thick has a thermal conductivity of  $\lambda = 0.90 \text{ W/m}\cdot\text{K}$ . This wall has glass wool insulation (TECH Slab 3.0) 80 mm thick and with  $\lambda_{108^\circ\text{C}} = 0.049 \text{ W/m}\cdot\text{K}$  of thermal conductivity. The temperatures of the inner and outer surfaces that were measured were found to be  $T_{\infty 1} = 180^\circ\text{C}$  (453 K) and  $T_{\infty 2} = 36^\circ\text{C}$  (309 K), respectively. The heat transfer coefficients of the inner and outer surfaces of the wall are  $h_{\text{surf},i} = 17.2 \text{ W/m}^2 \text{ K}$  y  $h_{\text{surf},e} = 17.2 \text{ W/m}^2 \text{ K}$ , which include radiation. Determine the heat loss through the wall on that day.

SOLUTION

1. The two surfaces of the wall are kept at the specified temperatures.
2. The heat transfer through the wall is stable, since the surface temperatures remain constant at the specified values.
3. The heat transfer is one-dimensional, since any significant temperature gradients will exist in the direction from the inside to the outside.
4. The thermal conductivity is constant in each layer.

A problem related to conduction and convection in a multi-layer wall arises, with the easiest way to solve it being the concept of thermal resistance as shown below based on equation [2.37]:

$$q = \frac{T_{\infty 1} - T_{\infty 2}}{R'_{\text{total}}}$$

Since all the resistors are in series, the total resistance is

$$R'_{\text{total}} = R_{\text{sup},1} + R_{\text{wall},1} + R_{\text{wall},2} + R_{\text{sup},2} = \frac{1}{h_{\text{sup},1}} + \frac{d_1}{\lambda_1} + \frac{d_2}{\lambda_2} + \frac{1}{h_{\text{sup},2}}$$

where:

$$\left. \begin{aligned} R_{\text{sup},1} &= \frac{1}{h_{\text{sup},1}} = \frac{1}{17.2 \text{ W/m}^2\text{K}} = 0.058 \text{ m}^2\text{K/W} \\ R_{\text{wall},1} &= \frac{d}{\lambda} = \frac{0.07 \text{ m}}{0.049 \text{ W/m}\cdot\text{K}} = 1.43 \text{ m}^2\text{K/W} \\ R_{\text{wall},2} &= \frac{d}{\lambda} = \frac{0.30 \text{ m}}{0.90 \text{ W/m}\cdot\text{K}} = 0.33 \text{ m}^2\text{K/W} \\ R_{\text{sup},2} &= \frac{1}{h_{\text{sup},2}} = \frac{1}{17.2 \text{ W/m}^2\text{K}} = 0.058 \text{ m}^2\text{K/W} \end{aligned} \right\} R'_{\text{total}} = 0.058 + 0.330 + 1.43 + 0.058 = 1.86 \text{ m}^2\text{K/W}$$

Thus:

$$q_T = \frac{T_1 - T_2}{R_T} = \frac{T_1 - T_2}{R_{\text{sup},1} + R_{\text{wall}} + R_{\text{sup},2}} = \frac{(453 - 309)}{2.076} = 69.36 \text{ W/m}^2$$

As we can see, with this multi-layer flat wall, the heat transfer coefficients and the insulation that covers the wall are taken into account, and so the heat transfer process decelerates even more with respect to example 1 and example 3, so there is less heat loss.

**1.4.2. In cylinders and spheres**

**a) Cylindrical and spherical elements with a single layer**

Let's consider a hollow cylinder, where the outer and inner surface temperatures remain constant. The transfer of heat through the hollow cylinder is then considered stationary and one-dimensional.

In a steady state, the cylinder temperature does not vary with time at any point. Therefore, the speed of heat transfer to the cylinder must be equal to the speed of the transfer out of it. That is, the heat transfer through the cylinder must be constant,  $q_{cyl} = \text{constant}$ .

When considering a cylinder considerably greater than the diameter with average conductivity (Figure 14), the two surfaces of the cylindrical layer are maintained at constant temperatures  $T_{si}$  and  $T_{se}$ . No heat is generated in the layer and the thermal conductivity is constant. Fourier's law of heat conduction for heat transfer through the cylindrical layer can then be expressed as:

$$[2.38] \quad q_{cyl} = -\lambda A \frac{dT}{dr}$$

where:

- $q_{cyl}$  heat flow for the cylindrical element (W/m)
- $\lambda$  thermal conductivity of the material (W/mK)
- $A$  area of the cylinder

By separating the variables from the equation and integrating, we obtain:

$$[2.39] \quad \int_{T_{si}}^{T_{se}} \frac{q_{cyl}}{A} dr = - \int_{T_{si}}^{T_{se}} \lambda dT$$

Substituting  $A = 2\pi rL$ , the following expression is obtained when performing the integration:

$$[2.40] \quad q_{cyl} = 2\pi L \lambda \frac{T_{si} - T_{se}}{\ln\left(\frac{D_o}{D_i}\right)}$$

To obtain a one-dimensional conduction, we speak of heat transfer flow density per unit of length. So:

$$[2.41] \quad \frac{q_{cyl}}{L} = 2\pi \lambda \frac{T_{si} - T_{se}}{\ln\left(\frac{D_o}{D_i}\right)} \quad \text{or} \quad \frac{q_{cyl}}{L} = 2\pi \lambda \frac{T_{si} - T_{se}}{\ln\left(\frac{D_o}{D_i}\right)}$$

Figure 14. Distribution of the  $T^{\circ}$  in a single-layer cylindrical element

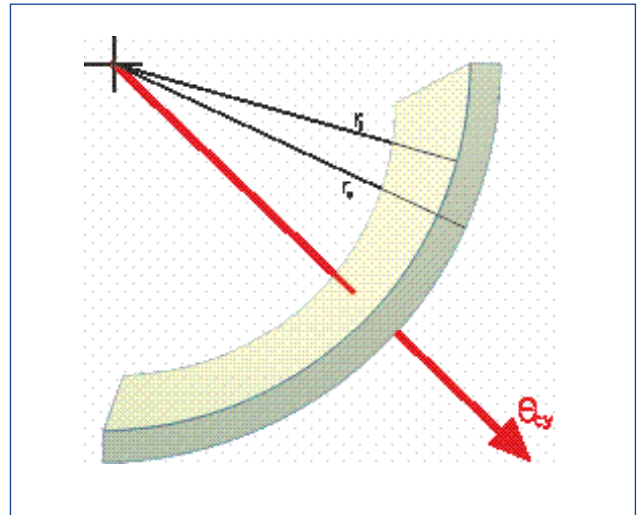

The thermal resistance of the cylinder being

$$[2.42] \quad R_{cyl} = \frac{\ln\left(\frac{r_o}{r_i}\right)}{2\pi\lambda} \quad \text{or} \quad R_{cyl} = \frac{\ln\left(\frac{D_o}{D_i}\right)}{2\pi\lambda}$$

where:

- $R_{cyl}$  thermal resistance of the cylinder (mK/W)
- $\lambda$  thermal conductivity of the material (W/m·K)
- $L$  length of the cylinder (m)
- $r_{si}$  radius inner surface (m)
- $r_{se}$  radius outer surface (m)
- $D_{si}$  interior surface diameter (m)
- $D_{se}$  exterior surface diameter (m)

Therefore, the equation of the heat flow density of the pipeline for a cylindrical element with a single layer is simplified as follows:

$$[2.43] \quad q_{cyl} = \frac{T_{si} - T_{se}}{R_{cyl}}$$

where:

- $q_{cyl}$  heat flow of the cylinder (W/m)
- $R_{cyl}$  thermal resistance of the cylinder (mK/W)
- $T_{si}$  internal surface temperature (K)
- $T_{se}$  outer temperature (K)

The previous analysis can be repeated by calculating it for a spherical layer; when taking  $A = 4\pi r^2$ , the result is expressed as:

$$[2.44] \quad q_{sph} = \frac{T_{si} - T_{se}}{R_{sph}}$$

where:

- $q_{sph}$  heat flow of the sphere (W)
- $R_{sph}$  thermal resistance of the cylindrical element (K/W)
- $T_{si}$  internal surface temperature (K)
- $T_{se}$  external surface temperature (K)

where the thermal resistance of a spherical layer is given by

$$[2.45] \quad R = \frac{r_{se} - r_{si}}{4\pi\lambda r_{si}r_{se}} \quad \text{or} \quad R = \frac{1}{2\pi\lambda} \left( \frac{1}{D_i} - \frac{1}{D_o} \right)$$

where:

- $R$  thermal resistance of the sphere (mK/W)
- $\lambda$  thermal conductivity of the material (W/m·K)
- $r_{si}$  radius inner surface (m)
- $r_{se}$  radius outer surface (m)
- $D_{si}$  interior surface diameter (m)
- $D_{se}$  exterior surface diameter (m)

Figure 15. Distribution of the temperature in a single-layer, spherical element

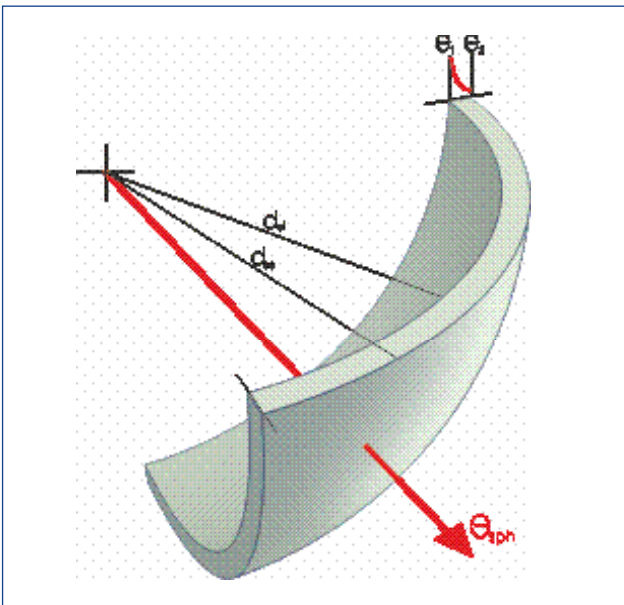

### b) Multi-layer cylindrical and spherical elements

The density of flow by conduction in a steady state through multi-layer cylindrical elements can be expressed as:

$$[2.46] \quad q_{cyl,m} = \frac{T_{si} - T_{se}}{R_{cyl,m}}$$

where:

- $q_{cyl,m}$  heat flow of the cylinder (W/m)
- $T_{si}$  internal surface temperature (K)
- $T_{se}$  external surface temperature (K)
- $R_{cyl}$  thermal resistance of the multi-layer cylinder (mK/W)

The thermal resistance of a multi-layer cylindrical element is:

$$[2.47] \quad R_{cyl,m} = \frac{1}{2\pi} \sum_{j=1}^n \left( \frac{1}{\lambda} \cdot \ln \frac{D_{ej}}{D_{ij}} \right)$$

where:

- $R_{cyl}$  thermal resistance of the multi-layer cylinder (mK/W)
- $\lambda$  thermal conductivity of the material (W/m·K)
- $D_{ij}$  interior surface diameter (m)
- $D_{ej}$  exterior surface diameter (m)

Figure 16. Distribution of the temperature in a multi-layer, cylindrical element.

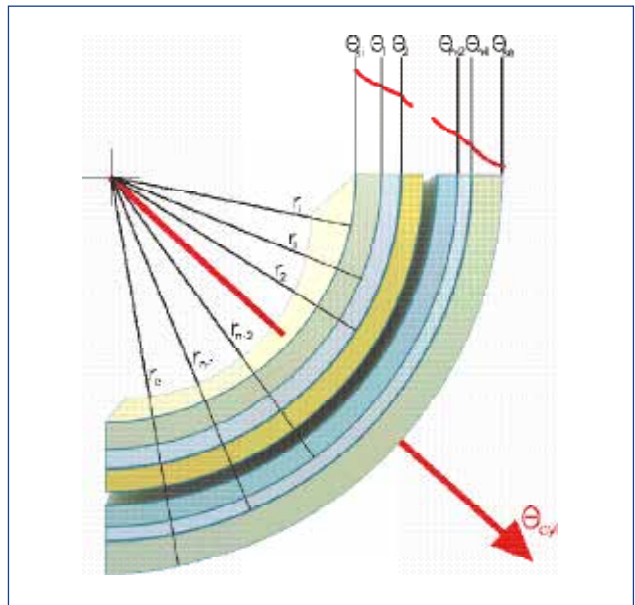

## EXAMPLE 5: HEAT LOSS IN MULTI-LAYER CYLINDRICAL ELEMENT

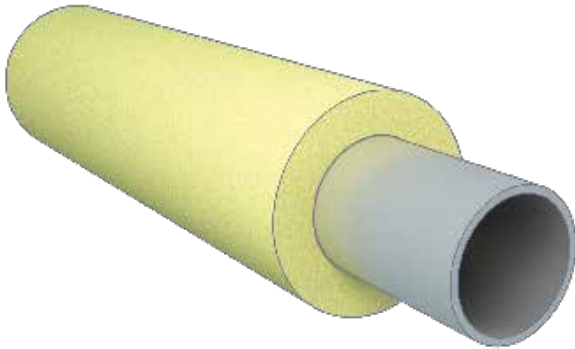

Considering a steel pipe of 6 m length, a diameter of  $D_i = 100$  mm and thickness  $d = 10$  mm, it has a thermal conductivity of  $\lambda = 50$  W/m·K. The tube conducts a liquid at  $340$  °C and is covered with a mineral wool insulation (TECH Pipe Section MT 4.1) which has a thickness of 80 mm and thermal conductivity  $\lambda_{200^\circ\text{C}} = 0.064$  W/m·K. The temperature of the inner surface is  $T_{si} = 340$  °C (613 K), with the external temperature being  $T_{se} = 59$  °C (332 K). Determine the heat loss by pipeline conduction.

## SOLUTION

1. The two surfaces of the wall are kept at the specified temperatures.
2. The heat transfer through the wall is stable, since the surface temperatures remain constant at the specified values.
3. The heat transfer is one-dimensional, since any significant temperature gradients will exist in the direction from the inside to the outside.
4. The thermal conductivity is constant in each layer.

Taking into account the above points, and given that the thickness of the insulation is  $d = 80$  mm = 0.080 m, the obtained data will be:

Parameters	Layer 1	Layer 2
Inside diameter (m)	$D_{i,1} = 0.100$	$D_{i,2} = 0.120$
Outside diameter (m)	$D_{e,1} = 0.120$	$D_{e,2} = 0.280$
Thermal conductivity (W/mk)	$\lambda_1 = 50$	$\lambda_2 = 0.064$

Therefore, to determine the heat loss of the multi-layer hot water pipe, we consider equation [2.47]:

$$q_{cyl,m} = \frac{T_{si} - T_{se}}{R_{cyl,m}}$$

where

$$R_{cyl} = \frac{1}{2\pi} \sum_{j=1}^n \left( \frac{1}{\lambda} \cdot \ln \frac{D_{e,j}}{D_{i,j}} \right) = \frac{1}{2\pi} \left[ \left( \frac{1}{\lambda_1} \cdot \ln \frac{D_{e,1}}{D_{i,1}} \right) + \left( \frac{1}{\lambda_2} \cdot \ln \frac{D_{e,2}}{D_{i,2}} \right) \right] = 2.11 \text{ mK/W}$$

Substituting in the equation [2.47]:

$$q_{cyl,m} = \frac{(T_{si} - T_{se})}{R_{cyl,m}} = \frac{613 - 332}{2.11} = 133.17 \text{ W/m}$$

For a multi-layer, spherical element, the steady heat transfer can be expressed as:

$$[2.48] \quad q = \frac{T_{si} - T_{se}}{R_{sph,m}}$$

where:

- q heat flow of the sphere (W)
- $T_{si}$  internal surface temperature (K)
- $T_{se}$  external surface temperature (K)
- $R_{sph}$  thermal resistance of the multi-layer cylinder (K/W), expressed as:

$$[2.49] \quad R_{sph,m} = \frac{1}{2\pi} \sum_{j=1}^n \frac{1}{\lambda} \left( \frac{1}{D_{j-1}} - \frac{1}{D_j} \right)$$

where:

- thermal conductivity of the material (W/m·K)
- $D_{ij}$  interior surface diameter (m)
- $D_{ej}$  exterior surface diameter (m)

Figure 17. Distribution of the temperature in a multi-layer, spherical element.

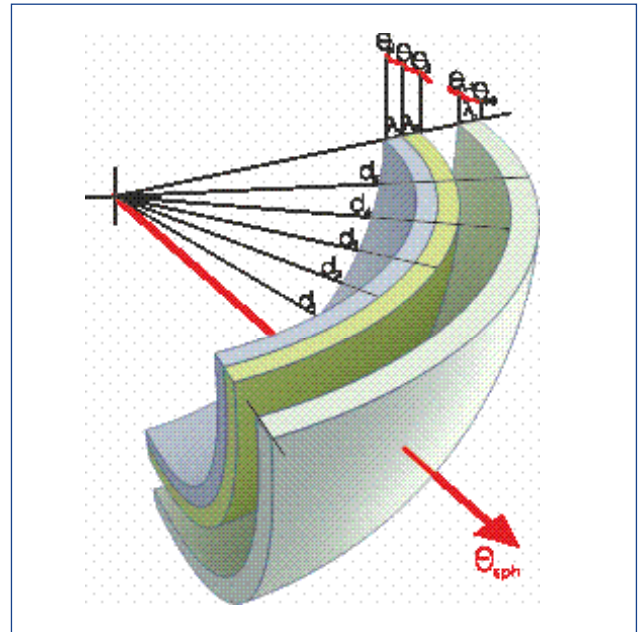

## EXAMPLE 6: HEAT LOSS IN MULTI-LAYER SPHERICAL ELEMENT

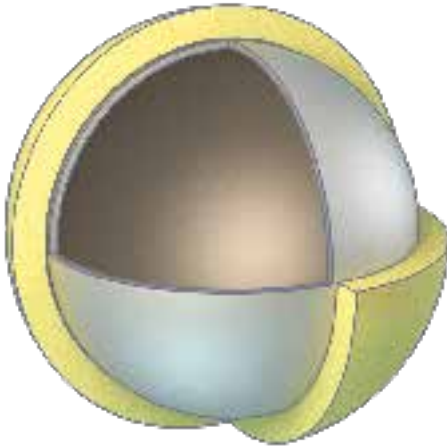

Considering a spherical steel tank ( $\lambda = 50 \text{ W/mK}$ ) with an internal diameter of 3 m and 1 cm thick that stores molten salts at a temperature of  $T_{st} = 500 \text{ }^\circ\text{C}$  (773 K), with the outside surface temperature being  $T_{se} = 100 \text{ }^\circ\text{C}$  (373 K). In this case, the spherical tank is covered by a mineral wool insulation (TECH Wired Mat MT 5.1), which has a thickness of 100 mm and thermal conductivity  $\lambda = 0.083 \text{ W/m}\cdot\text{K}$ . Determine the heat loss of the spherical tank.

## SOLUTION

1. The two surfaces of the wall are kept at the specified temperatures.
2. The heat transfer through the wall is stable, since the surface temperatures remain constant at the specified values.
3. The heat transfer is one-dimensional, since any significant temperature gradients will exist in the direction from the inside to the outside.
4. The thermal conductivity is constant in each layer.

Taking into account the above points, and given that the thickness of the insulation is  $d_2 = 0.1 \text{ m}$ , the obtained data are:

Parameters	Layer 1	Layer 2
Inside diameter (m)	$D_{i,1} = 3.00$	$D_{i,2} = 3.02$
Outside diameter (m)	$D_{e,1} = 3.02$	$D_{e,2} = 3.22$
Thermal conductivity (W/m·K)	$\lambda_1 = 50$	$\lambda_2 = 0.083$

Therefore, to determine the heat flow of the multi-layer spherical tank, we consider equation [2.47]:

$$q_{sph,m} = \frac{T_{st} - T_{se}}{R_{sph,m}}$$

The thermal resistance of the sphere with several layers being:

$$R_{sph,m} = \frac{1}{2\pi} \sum_{j=1}^n \frac{1}{\lambda_j} \left( \frac{1}{D_{j-1}} - \frac{1}{D_j} \right) = \frac{1}{2\pi} \left[ \frac{1}{\lambda_1} \left( \frac{1}{D_{i,1}} - \frac{1}{D_{e,1}} \right) + \frac{1}{\lambda_2} \left( \frac{1}{D_{e,1}} - \frac{1}{D_{e,2}} \right) \right] = \frac{1}{2\pi} \left[ \frac{1}{50} \left( \frac{1}{3.00} - \frac{1}{3.02} \right) + \frac{1}{0.083} \left( \frac{1}{3.02} - \frac{1}{3.22} \right) \right] = 0.039 \text{ K/W}$$

Substituting in the equation [2.47]:

$$q_{sph,m} = \frac{T_{st} - T_{se}}{R_{sph,m}} = \frac{773 - 373}{0.039} = 10,256.41 \text{ W}$$

## Thermal resistance to convection and radiation for cylindrical and spherical elements

### • Network of thermal resistors for single-layer cylindrical and spherical elements

If we consider the one-dimensional flow in a stable state through a cylindrical layer that is exposed to convection and radiation the speed of heat transfer can be expressed as:

$$[2.50] \quad q = \frac{T_{\infty i} - T_{\infty e}}{R''_{total}}$$

where:

$q$  heat flow of the sphere (W)

$T_{\infty i}$  inside surface temperature (K)

$T_{\infty e}$  outside surface temperature (K)

$R''_{total}$  total thermal resistance of the cylinder (mK/W), expressed as:

$$[2.51] \quad R''_{total} = R_{sup,1} + R_{cyl} + R_{sup,2} = \frac{1}{A_{s,1} h_{sup,1}} + \frac{\ln(D_e/D_i)}{2\pi\lambda} + \frac{1}{A_{s,2} h_{sup,2}}$$

where:

$h_n$  surface coefficient of heat transfer by convection including the effects of radiation (W/m<sup>2</sup>·K)

$R_{sup,n}$  thermal resistance exposed to convection and radiation (K/W)

$A_{s,n}$  surface area of the cylinder ( $A = 2\pi r_n L$ )

thermal conductivity of the material (W/m·K)

$D_i$  interior surface diameter (m)

$D_e$  exterior surface diameter (m)

The thermal resistors are also in series in this case and therefore the total thermal resistance is determined by adding each of the resistances, as in the electrical resistances connected in series.

For a spherical layer exposed to convection and radiation, if we consider the one-dimensional flow in a steady state, the speed of heat transfer can be expressed as:

$$[2.52] \quad q = \frac{T_{\infty i} - T_{\infty e}}{R''_{total}}$$

where:

$q$  heat flow of the sphere (W)

$T_{\infty i}$  temperature away from the inside surface (K)

$T_{\infty e}$  temperature away from the outside surface (K)

$R''_{total}$  total thermal resistance of the cylinder (mK/W). expressed as:

$$[2.53] \quad R''_{total} = R_{sup,i} + R_{sph} + R_{sup,e} = \frac{1}{A_{s,i} h_{sup,i}} + \frac{\frac{1}{D_i} - \frac{1}{D_e}}{2\pi\lambda} + \frac{1}{A_{s,e} h_{sup,e}}$$

where:

$h_n$  surface coefficient of heat transfer by convection including the effects of radiation (W/m<sup>2</sup>·K)

$R_{sup,n}$  thermal resistance exposed to convection and radiation (K/W)

$A_{s,n}$  surface area of the sphere ( $A = 2\pi r_n^2$ )

thermal conductivity of the material (W/m·K)

$D_i$  interior surface diameter (m)

$D_e$  exterior surface diameter (m)

The thermal resistors are also in series in this case and, therefore, the total thermal resistance is determined by adding each of the resistances, as in the electrical resistances connected in series.

Figure 18. Network of thermal resistors for a cylindrical (or spherical) element exposed to convection on both the inside and outside.

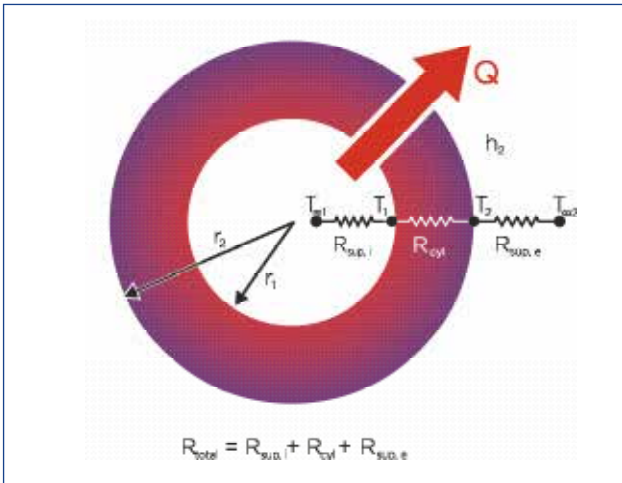
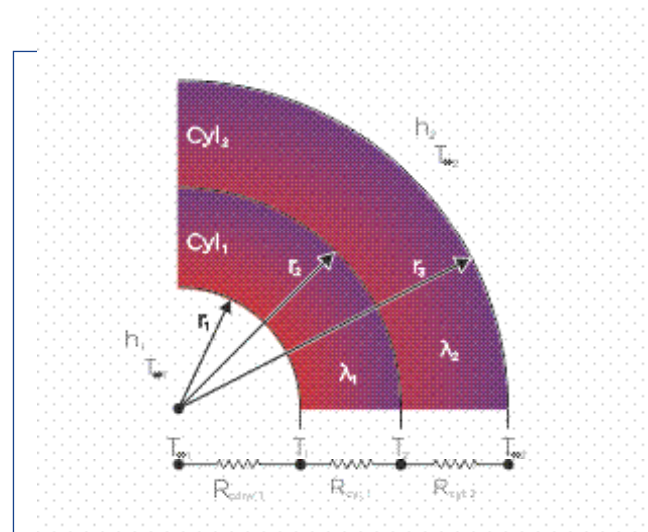

Figure 19. Network of thermal resistors for transferring heat through a cylinder of two layers exposed



• Network of thermal resistors for multi-layer cylindrical and spherical elements

The steady heat transfer through multi-layered cylindrical or spherical elements can be analysed in the same way as the multi-layer flat walls mentioned above, adding an additional resistor in series for each additional layer.

The speed of stationary heat transfer through multi-layer cylindrical elements exposed to convection and radiation can be expressed as:

$$[2.54] \quad q = \frac{T_{\infty i} - T_{\infty e}}{R''_{total}}$$

- q heat flow of the cylinder (W)
- T<sub>∞i</sub> temperature away from the inside surface (K)
- T<sub>∞e</sub> temperature away from the outside surface (K)
- R<sub>total</sub> total thermal resistance of the cylinder (mK/W), expressed as:

$$[2.55] \quad R''_{total} = R_{sup,i} + R_{cyt} + R_{sup,e} = \frac{1}{A_{s,i} h_{sup,i}} + \frac{\ln\left(\frac{r_{e,1}}{r_{i,1}}\right)}{2\pi\lambda} + \frac{\ln\left(\frac{r_{e,2}}{r_{e,1}}\right)}{2\pi\lambda_2} + \frac{1}{A_{s,e} h_{sup,e}}$$

where:

- h<sub>n</sub> surface coefficient of heat transfer by convection including the effects of radiation (W/m<sup>2</sup>·K)
- R<sub>cyt</sub> thermal resistance of the cylinder (K/W)
- R<sub>sup,n</sub> thermal resistance exposed to convection and radiation (K/W)
- A<sub>s,n</sub> surface area of the cylinder (A = 2πr<sub>n</sub>L)
- λ thermal conductivity of the material (W/m·K)
- Di interior surface diameter (m)
- De exterior surface diameter (m)

EXAMPLE 7: NETWORK OF THERMAL RESISTORS FOR MULTI-LAYER CYLINDRICAL ELEMENT

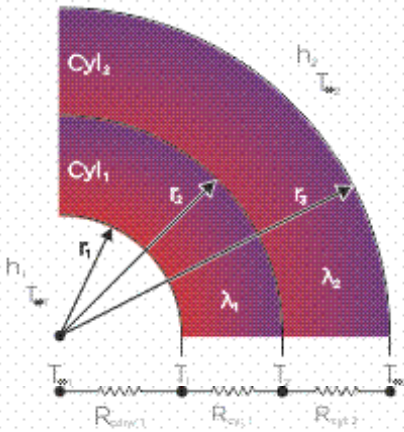

Taking EXAMPLE 5: A steel pipe ( $\lambda = 50 \text{ W/m}\cdot\text{K}$ ) with a length of 6 m, a diameter of  $D_i = 100 \text{ mm}$  and a thickness of  $d = 10 \text{ mm}$  conducts a liquid, with the inside temperature being  $T_{\infty i} = 340 \text{ }^\circ\text{C}$  (613 K). In this case, the pipe is covered with a mineral wool insulation (TECH Pipe Section MT 4.1) with a thickness of 80 mm and thermal conductivity of  $\lambda = 0.064 \text{ W/m}\cdot\text{K}$ . Heat is lost to the surroundings that are at a temperature of  $T_{\infty e} = 59 \text{ }^\circ\text{C}$  (332 K) by means of natural convection and radiation with a surface heat transfer coefficient of  $h_e = 6 \text{ W/m}^2$ . Determine the heat loss of the hot water pipe.

SOLUTION

1. The heat transfer is stable since the specified thermal conditions are maintained over time.
2. The heat transfer is one-dimensional, since any significant temperature gradients will exist in the direction from the inside to the outside.
3. The thermal conductivity is constant in each layer.

Taking into account the above, and given that the thickness of the insulation is  $d = 30 \text{ mm} = 0.03 \text{ m}$ , the obtained data will be:

Parameters	Layer 1	Layer 2
Inside diameter (m)	$D_{i,1} = 0.100$	$D_{i,2} = 0.120$
Outside diameter (m)	$D_{e,1} = 0.120$	$D_{e,2} = 0.280$
Thermal conductivity (W/mk)	$\lambda_1 = 50$	$\lambda_2 = 0.064$

Therefore, to determine the heat loss of the hot water pipe exposed to convection and radiation, we consider equation [2.54]:

$$q = \frac{T_{\infty 1} - T_{\infty 2}}{R''_{total}}$$

Since all the resistances are in series, we have:

$$R''_{total} = R_{sup,i} + R_{cy1} + R_{sup,e} = \frac{\ln\left(\frac{D_{e,1}}{D_{i,1}}\right)}{2\pi\lambda_1} + \frac{\ln\left(\frac{D_{e,2}}{D_{e,1}}\right)}{2\pi\lambda_2} + \frac{1}{A_{s,e}h_{sup,e}}$$

$$R''_{total} = R_{sup,i} + R_{cy1} + R_{cy2} + R_{sup,e} = \frac{\ln\left(\frac{D_{e,1}}{D_{i,1}}\right)}{2\pi\lambda_1} + \frac{\ln\left(\frac{D_{e,2}}{D_{e,1}}\right)}{2\pi\lambda_2} + \frac{1}{(2\pi r_{e,2}L)h_2}$$

$$= \frac{1}{2 \cdot \pi \cdot 0.050 \cdot 6 \cdot 20} + \frac{\ln\left(\frac{0.120}{0.100}\right)}{2\pi 50} + \frac{\ln\left(\frac{0.280}{0.120}\right)}{2\pi 0,064} + \frac{1}{2 \cdot \pi \cdot 0.140 \cdot 6 \cdot 6}$$

$$R''_{total} = 0.0265 + 0.00058 + 2.11 + 0.0315 = 2.168 \text{ K/W}$$

Then, substituting in equation [2.54], the heat loss would be:

$$q = \frac{T_{\infty 1} - T_{\infty 2}}{R''_{total}} = \frac{(613 - 332) \text{ K}}{2.168 \text{ K/W}} = 129.61 \text{ W}$$

(per linear metre of pipe)

**As we can see with respect to example 5, the heat loss is lower and the heat transfer is decelerated, taking into account the surface heat transfer coefficients.**

**Note:  $R_{\text{surf},i}$  is 0 since  $h_i$  tends to infinity in the case of liquids.**

The speed of stationary heat transfer through multi-layer spherical elements exposed to convection and radiation can be expressed as:

$$[2.56] \quad q = \frac{T_{\infty 1} - T_{\infty 2}}{R''_{total}}$$

where

$q$  heat flow of the cylinder (W)

$T_{\infty i}$  temperature away from the inside surface (K)

$T_{\infty e}$  temperature away from the outside surface (K)

$R_{total}$  total thermal resistance of the cylinder (mK/W), expressed as:

$$[2.57] \quad R''_{total} = R_{\text{sup},i} + R_{\text{sph}} + R_{\text{sup},e} = \frac{1}{A_{s,i} h_{\text{sup},i}} + \frac{(r_{e,1} - r_{i,1})}{4\pi r_{i,1} r_{e,1} \lambda} + \frac{(r_{e,2} - r_{e,1})}{4\pi r_{e,1} r_{e,2} \lambda} + \frac{1}{A_{s,e} h_{\text{sup},e}}$$

where:

$h_n$  surface coefficient of heat transfer by convection and radiation (W/m<sup>2</sup>·K)

$R_{\text{esf}}$  thermal resistance of the sphere (K/W)

$R_{\text{sup},n}$  thermal resistance exposed to convection and radiation (K/W)

$A_{s,n}$  surface area of the sphere ( $A = 4\pi r^2$ )

thermal conductivity of the material (W/m·K)

$D_i$  interior surface diameter (m)

$D_e$  exterior surface diameter (m)

Once again, the resistors are in series and, therefore, the total thermal resistance is simply the arithmetic sum of each of the thermal resistors found in the path of the heat flow.

### EXAMPLE 8: NETWORK OF THERMAL RESISTORS FOR MULTI-LAYER SPHERICAL ELEMENT

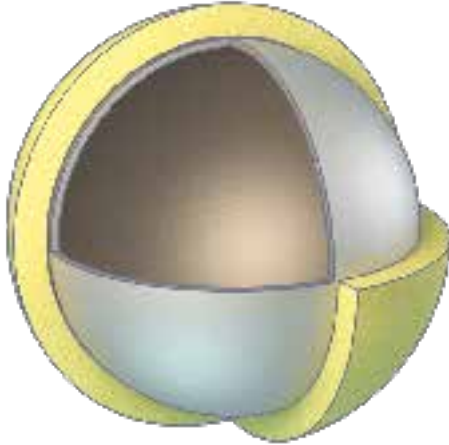

Taking EXAMPLE 6: A spherical steel tank ( $\lambda = 50 \text{ W/mK}$ ) with an internal diameter of 3 m and 1 cm thick stores molten salts at a temperature of  $T_{si} = 500 \text{ }^\circ\text{C}$  (773 K). In this case, the spherical tank is covered by a mineral wool insulation (TECH Wired Mat MT 5.1), which has a thickness of 100 mm and thermal conductivity  $\lambda = 0.083 \text{ W/m}\cdot\text{K}$ . The spherical tank is located outside, with the temperature of  $T_{se} = 100 \text{ }^\circ\text{C}$  (373 K). The heat is transferred between the outer surface of this and the surroundings by means of natural convection and radiation. The surface heat transfer coefficients of the inside and outside are  $h_i = 20 \text{ W/m}^2$  and  $h_e = 10 \text{ W/m}^2$  respectively. Determine the heat loss of the spherical tank.

#### SOLUTION

1. The heat transfer is stable since the specified thermal conditions do not change over time.
2. The heat transfer is one-dimensional, since any significant temperature gradients will exist in the direction from the inside to the outside.
3. The thermal conductivity is constant in each layer.

Given that:

Parameters	Layer 1	Layer 2
Inside diameter (m)	$D_{i1} = 3.0$	$D_{i2} = 3.02$
Outside diameter (m)	$D_{e1} = 3.02$	$D_{e2} = 3.22$
Thermal conductivity (W/mk)	$\lambda_1 = 50$	$\lambda_2 = 0.083$

Therefore, to determine the heat flow of the spherical tank, we consider equation [2.56]:

$$Q_{\text{loss}} = \frac{T_{\text{in}} - T_{\text{out}}}{R_{\text{total}}}$$

Since all the resistors are in series, the total resistance is:

$$R_{\text{total}} = R_{\text{conv},i} + R_{\text{cond},1} + R_{\text{conv},e} = \frac{1}{h_i} \frac{1}{4\pi D_{i1}^2} + \frac{\lambda_1}{4\pi \lambda_1 D_{i1} D_{e1}} + \frac{1}{h_e} \frac{1}{4\pi D_{e2}^2} = \frac{1}{2\pi \lambda_1} \left( \frac{1}{D_{i1}} + \frac{1}{D_{e1}} \right) + \frac{1}{4\pi \lambda_2 D_{e2}^2}$$

$$R_{\text{total}} = \frac{1}{2\pi \cdot 50} \left( \frac{1}{3.0} + \frac{1}{3.02} \right) + \frac{1}{4\pi \cdot 0.083 \cdot 3.22^2}$$

$$R_{\text{total}} = 7.826 \cdot 10^{-3} + 0.0374 + 0.00511 = 0.044 \frac{\text{K}}{\text{W}}$$

Then, substituting in equation [2.56], the heat loss would be:

$$q = \frac{T_{\text{in}} - T_{\text{out}}}{R_{\text{total}}} = \frac{(773 - 373) \text{ K}}{0.0458 \text{ K/W}} = 9,090.91 \text{ W}$$

Note:  $R_{\text{surf},i}$  is 0 since  $h_i$  tends to infinity in the case of liquids

### 1.4.3. In rectangular sections

The speed of heat transfer through the wall of a conduit with a rectangular section is given by:

$$[2.58] \quad q = \frac{T_{si} - T_{se}}{R_{rect}}$$

where:

- q heat flow of the rectangular section (W/m)
- $T_{si}$  internal surface temperature (K)
- $T_{se}$  external surface temperature (K)
- $R_{rect}$  thermal resistance of the conduit wall (m K/W), calculated approximately as follows:

$$[2.59] \quad R_{rect} = \frac{2d}{\lambda(P_e + P_i)} \text{ (mk)/W}$$

where:

- $P_i$  inside perimeter of the conduit
- $P_e$  outside perimeter of the conduit, expressed as

$$[2.60] \quad P_e = P_i + (8 \cdot d)$$

- d thickness of the insulating layer (m)

Figure 20. Distribution of temperature in the wall from a rectangular conduit.

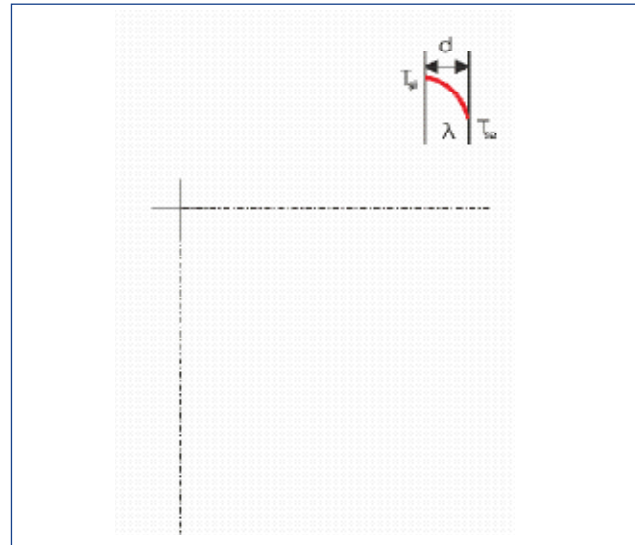

## EXAMPLE 9: HEAT LOSS IN RECTANGULAR SECTIONS

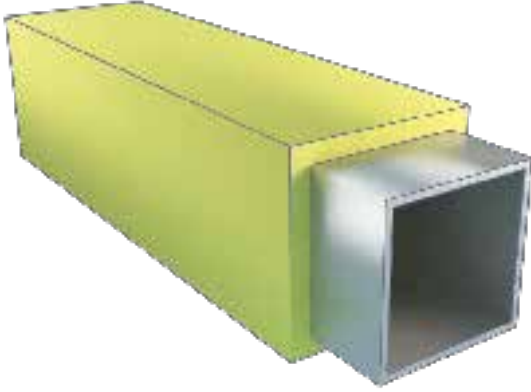

Let's consider a hot gas recovery conduit which is 3.00 m long, 1 m wide and 1 m high, whose internal and external temperature is  $T_{si}=360\text{ }^{\circ}\text{C}$  (633 K) and  $T_{se}=40\text{ }^{\circ}\text{C}$  (313 K) respectively. This conduit is covered by a mineral wool panel (TECH Slab MT 5.1) with a thickness of 200 mm and whose thermal conductivity is  $200\text{ }^{\circ}\text{C} = 0.065\text{ W/(m K)}$ . Determine the heat loss of the gas recovery conduit.

## SOLUTION

1. The heat transfer is stable since the specified thermal conditions do not change over time.
2. The heat transfer is one-dimensional, since any significant temperature gradients will exist in the direction from the inside to the outside.
3. The thermal conductivity is constant.

Since the length of the conduit is 3 m, the width and height is 1 m and the thickness of the insulation is 200 mm (0.2 m), the inside and outside perimeter would be:

$$P_i = 1.0 + 1.0 + 1.0 + 1.0 = 4\text{ m}$$

$$P_e = P_i + (8 \cdot 0.2) = 5.6\text{ m}$$

To determine the heat flow of the air conditioning conduit, we consider equation [2.58]:

$$q = \frac{T_{st} - T_{se}}{R_{rect}}$$

where the thermal resistance of the conduit can be approximately calculated by:

$$R_{rect} = \frac{2d}{\lambda(P_e + P_i)} = \frac{2 \cdot 0,2}{0.065(4 + 5.6)} = 0.641\text{ (m K)/W}$$

Thus,

$$q = \frac{T_{st} - T_{se}}{R_{rect}} = \frac{633 - 313}{0.641} = 499.22\text{ W/m}$$

$$q = 124.80\text{ W/m}^2$$

## 1.5. Thermal transmittance

The thermal transmittance,  $U$ , for a flat wall is the amount of heat flow in steady state that passes per unit of area, and is divided by the temperature difference in the vicinity of both sides of the wall. Analogous expressions would have cylindrical and spherical walls according to:

$$U = \frac{q}{T_1 - T_{\infty 2}} \text{ W/(m}^2 \cdot \text{K)} \quad U_{\text{cyl}} = \frac{q_{\text{cyl}}}{T_1 - T_{\infty 2}} \text{ W/(m} \cdot \text{K)} \quad U_{\text{sph}} = \frac{q_{\text{sph}}}{T_1 - T_{\infty 2}} \text{ W/K}$$

where:

- $U$  thermal transmittance (W/m<sup>2</sup> K)
- $U_{\text{cyl}}$  thermal transmittance of cylindrical element (W/m K)
- $U_{\text{sph}}$  thermal transmittance of spherical element (W/ K)
- $q$  density of heat flow of flat wall (W/m)
- $q_{\text{cyl}}$  density of heat flow of cylindrical element (W/m)
- $q_{\text{sph}}$  density of heat flow of spherical element (W/m)
- $T_1$  inside surface temperature (K)
- $T_{\infty 2}$  temperature away from the outside surface (K)

The thermal transmittance takes into account the different components of the material; that is, not only do we need to take into account the thermal resistance of the material, but also other supplementary resistances, which are called internal and external surface thermal resistance, due to the difficulties of heat exchanges between the material and the air (heat transfer by convection and radiation). Therefore, the thermal transmittance can be calculated as follows:

• For flat walls,

$$[2.59] \quad \frac{1}{U} = R_{\text{si}} + \sum R_{\text{wall},i} + R_{\text{se}} = \frac{1}{h_i} + \sum R_{\text{wall},i} + \frac{1}{h_e}$$

where:

- $U$  thermal transmittance (W/m<sup>2</sup> K)
- $R_{\text{si}}$  inside surface resistance (m<sup>2</sup> K/W)
- $R_{\text{se}}$  outside surface resistance (m<sup>2</sup> K/W)
- $R_{\text{wall}}$  thermal resistance of flat wall (m<sup>2</sup> K /W) [ $R_{\text{wall}} = \frac{d}{\lambda}$ ]
- $h_i$  surface transfer coefficient of inside heat (W/m<sup>2</sup>·K)
- $h_e$  surface transfer coefficient of outside heat (W/m<sup>2</sup>·K)

• For cylindrical walls,

$$[2.60] \quad \frac{1}{U_{\text{cyl}}} = R_{\text{si}} + \sum R_{\text{cyl},i} + R_{\text{se}} = \frac{1}{h_i \cdot \pi \cdot D_i} + \sum R_{\text{cyl},i} + \frac{1}{h_e \cdot \pi \cdot D_e}$$

where:

- $U$  thermal transmittance of cylindrical thermal element (W/m<sup>2</sup> K)
- $R_{\text{si}}$  inside surface resistance (m<sup>2</sup> K/W)
- $R_{\text{se}}$  outside surface resistance (m<sup>2</sup> K/W)
- $R_{\text{cyl}}$  thermal resistance of cylindrical element (m<sup>2</sup> K /W) [ $R_{\text{cyl}} = \frac{\ln(r_e/r_i)}{2\pi\lambda}$  or  $R_{\text{cyl}} = \frac{\ln(D_e/D_i)}{2\pi\lambda}$ ]
- $h_i$  surface transfer coefficient of inside heat (W/m<sup>2</sup>·K)
- $h_e$  surface transfer coefficient of outside heat (W/m<sup>2</sup>·K)
- $D_i$  interior diameter (m)
- $D_e$  exterior diameter (m)

- For spherical walls, thermal transmittance  $U_{\text{esf}}$  is derived from:

$$[2.61] \quad \frac{1}{U_{\text{sph}}} = R_{\text{st}} + \sum R_{\text{sph},l} + R_{\text{se}} = \frac{1}{h_i \cdot \pi \cdot D_i^2} + \sum R_{\text{sph},l} + \frac{1}{h_e \cdot \pi \cdot D_e^2}$$

where:

$U$  thermal transmittance of cylindrical element ( $\text{W}/\text{m}^2 \cdot \text{K}$ )

$R_{\text{si}}$  inside surface resistance ( $\text{m}^2 \text{K}/\text{W}$ )

$R_{\text{se}}$  outside surface resistance ( $\text{m}^2 \text{K}/\text{W}$ )

$R_{\text{sph}}$  thermal resistance of spherical element ( $\text{k}/\text{W}$ ) [ $R_{\text{sph}} = \frac{r_{\text{se}} - r_{\text{si}}}{2\pi\lambda r_{\text{si}} r_{\text{se}}}$  or  $R_{\text{sph}} = \frac{1}{2\pi\lambda} \left( \frac{1}{D_e} - \frac{1}{D_i} \right)$ ]

$h_i$  surface transfer coefficient of inside heat ( $\text{W}/\text{m}^2 \cdot \text{K}$ )

$h_e$  surface transfer coefficient of outside heat ( $\text{W}/\text{m}^2 \cdot \text{K}$ )

$D_i$  interior diameter (m)

$D_e$  exterior diameter (m)

The value of  $h_i$  is very high so the surface resistance,  $R_{\text{si}}$ , of liquids inside tanks and pipes is low and can be neglected. For the outer surface resistance  $R_{\text{se}}$ , the indicated equations are applied. For air ducts, it is also necessary to consider the inside surface coefficient.

The inverse of thermal transmittance is:

- For flat walls, the total thermal resistance,

$$[2.62] \quad \frac{1}{U} = R_T$$

- For cylindrical walls, the total linear thermal resistance,

$$[2.63] \quad \frac{1}{U_{\text{cyl}}} = R_{T\text{cyl}}$$

- For spherical walls, the total thermal resistance given is,

$$[2.64] \quad \frac{1}{U_{\text{sph}}} = R_{T\text{sph}}$$

## EXAMPLE 10: CALCULATION OF THERMAL TRANSMITTANCE IN A FLAT WALL

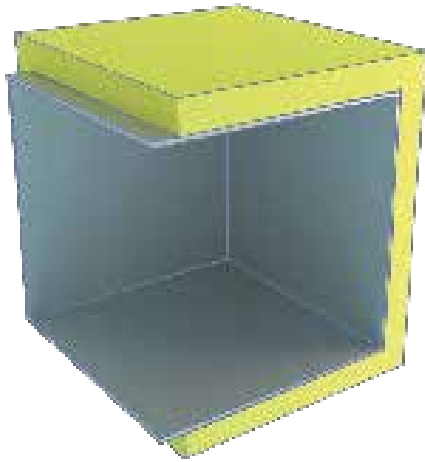

By way of example, considering a double-layer wall of an oven whose internal and external temperature is  $T_{si} = 750\text{ }^{\circ}\text{C}$  (1,023 K) and  $T_{se} = 50\text{ }^{\circ}\text{C}$  (323 K), it consists of the following materials:

1st layer: Refractory material zirconium brick with a thermal conductivity of  $\lambda_1 = 2.44\text{ W/mK}$  and a thickness of  $d = 0.150\text{ m}$ .

2nd layer: stone wool panel TECH Slab HT 6.1 with a thermal conductivity of  $\lambda_2 = 0.102\text{ W/mK}$  and a thickness of  $d = 0.250\text{ m}$ .

Determine the thermal transmittance, where the outer surface coefficient is  $h_e = 7.76\text{ W/(m}^2\text{K)}$  and taking into account that the interior surface coefficient is not considered.

According to what is seen in this section, the thermal transmittance of a flat wall is given by:

$$\frac{1}{U} = R_{st} + \sum R_{wall,t} + R_{se} = \frac{1}{h_t} + \sum R_{wall,i} + \frac{1}{h_e}$$

$$U = \frac{1}{\frac{0.150}{2.44} + \frac{0.250}{0.102} + \frac{1}{7.76}} = 0.379\text{ W/(m}^2\text{K)}$$

## 2. Temperature distribution

### 2.1. Intermediate temperature

The rate of heat transfer through a wall which separates "n" media is equal to the temperature difference divided by the total thermal resistance between the media. In this case, the thermal resistances are in series and the equivalent resistance is determined by adding each of the resistances. The general equation that gives us the loss of heat in a multi-layer element can be written in the following general way:

$$[2.65] \quad q = \frac{T_{\infty 1} - T_{\infty 2}}{R_T}$$

where:

$T_{\infty 1}$  temperature away from the inside surface (K)  
 $T_{\infty 2}$  temperature away from the outside surface (K)

with the total resistance being:

$$R_T = R_{si} + R_1 + R_2 + \dots + R_n + R_{se} \quad (\text{m}^2 \cdot \text{K}) / \text{W}$$

where:

$R_1$  thermal resistance of layer 1  
 $R_2$  thermal resistance of layer 2  
 $R_n$  thermal resistance of each individual layer  
 $R_{si}$  surface thermal resistance of the inside surface  
 $R_{se}$  surface thermal resistance of the outside surface

Considering a multi-layer flat wall, the relation between the resistance of each layer or the surface resistance with respect to the total resistance will give a measure of the temperature drop in each layer or surface (K); in this way, the fall of temperature through any layer is proportional to its resistance. The greater the resistance is, greater the drop in temperature. In fact, equation [2.65] can be rearranged to obtain:

$$[2.66] \quad \Delta T = qR$$

where:

$\Delta T$  fall in temperature (K)  
 $q$  heat flow (W/m<sup>2</sup>K)  
 $R$  thermal resistance through the layer (m<sup>2</sup>K/W)

Figure 21. Temperature distribution in a multi-layer flat wall, showing the linear dependence of the surface thermal resistance and the thermal resistances of each independent layer.

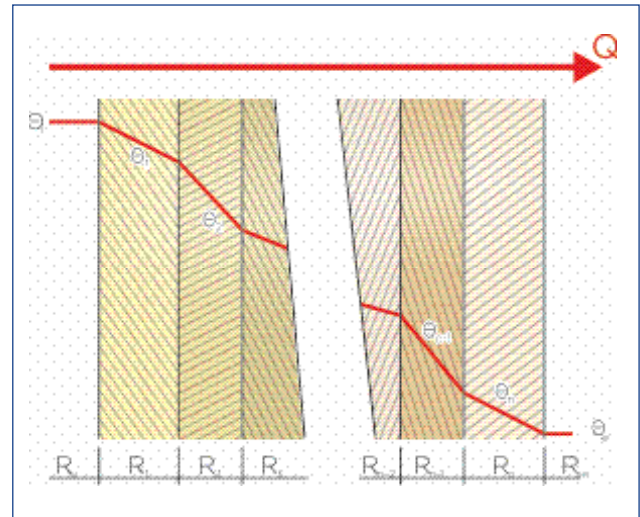

It is sometimes convenient to express the transfer of heat through a medium in a manner analogous to Newton's Law of Cooling, as

$$[2.67] \quad q = U\Delta T = U(T_{\infty 1} - T_{\infty 2})$$

where U is the total heat transfer. The comparison of equation [2.65] and [2.67] reveals that  $U = 1/R_{\text{total}}$ , as mentioned in the previous section.

The following equations are used to obtain the values for  $R_1$ ,  $R_2$ ,  $R_{si}$ ,  $R_{se}$  and  $R_T$ :

$$[2.68] \quad T_1 - T_2 = \frac{R_1}{R_T} \cdot (T_1 - T_a)$$

$$[2.69] \quad T_1 - T_{st} = \frac{R_{st}}{R_T} \cdot (T_1 - T_a)$$

$$[2.70] \quad T_2 - T_3 = \frac{R_2}{R_T} \cdot (T_1 - T_a)$$

$$[2.71] \quad T_{se} - T_a = \frac{R_{se}}{R_T} \cdot (T_1 - T_a)$$

## EXAMPLE 11: CALCULATION OF INTERMEDIATE TEMPERATURES

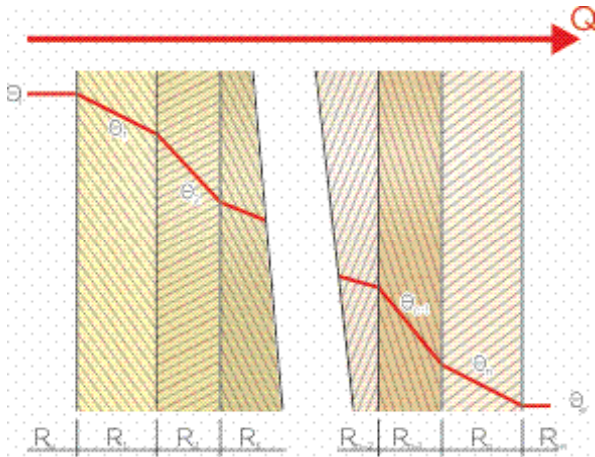

Based on EXAMPLE 10: Considering a double-layer wall of an oven whose internal and external temperature is  $T_{si} = 750$  (1,023 K) and  $T_{se} = 50$  °C (323 K) with a thermal transmittance of  $U = 0.661$  W/m<sup>2</sup>K, it consists of the following materials:

1st layer: Refractory material zirconium brick with a thermal conductivity of  $\lambda_1 = 2.44$  W/mK and a thickness of  $d = 0.150$  m.

2nd layer: stone wool panel TECH Slab HT 5.1 with a thermal conductivity of  $\lambda_2 = 0.102$  W/mK and a thickness of  $d = 0.250$  m.

With the outer surface coefficient being  $h_e = 7,76$  W/(m<sup>2</sup>K) and taking into account that the inside surface coefficient is not considered, assuming that the heat transfer rate is steady and there is no accumulation, calculate the surface temperature in each of the materials that make up the wall of the furnace.

## SOLUTION

1. The amount of heat that is passing through the wall is calculated, based on equation [2,67]:

$$q = U\Delta T = U (T_{\infty 1} - T_{\infty 2}) = 0.379 (1,023 - 323) = 265.3 \text{ W/m}^2$$

2. As a steady state is assumed, the amount of heat is that which passes through each of the layers of the material and, therefore:

$$T_1 - T_2 = \frac{R_1}{R_T} \cdot (T_1 - T_a) = q \cdot R_1 = 265.3 \cdot \frac{0.150}{2.44} = 16.31 \text{ }^\circ\text{C}$$

$$T_2 - T_3 = \frac{R_2}{R_T} \cdot (T_1 - T_a) = q \cdot R_2 = 265.3 \cdot \frac{0.250}{0.102} = 650.24 \text{ }^\circ\text{C}$$

## 2.2. Surface temperature

Since it is not possible to know all the parameters that come into play, it is difficult to guarantee the surface temperature.

For safety reasons, the calculation of the surface temperature is normally used to determine a limit value of the installation temperature.

In practice, the theoretical calculation can vary by different conditions. These can be the ambient temperature, the air movement, the state of the insulation surface, the radiative effect of the adjacent bodies, meteorological conditions, etc.

To obtain the surface temperature, we start from the previous formula; neglecting the  $R_{si}$ , as indicated before:

$$[2.72] \quad T_{se} = T_a + \frac{R_{se}}{R_T} \cdot (T_i - T_a)$$

When replacing the values  $R_{se}$  and  $R_T$ , for a single layer of insulation:

• For flat walls:

$$[2.73] \quad T_{se} = T_a + \frac{(T_i - T_a)}{\frac{k_e \cdot d}{\lambda} + 1}$$

• For cylindrical walls:

$$[2.74] \quad T_{se} = T_a + \frac{(T_i - T_a)}{\frac{k_e \cdot D_{ei} \cdot D_{e1}}{2\lambda} + \frac{D_{e1}}{D_i} + 1}$$



### 3. Prevention of surface condensation

In installations with a lower surface temperature than that of the ambient dew, condensation occurs.

The calculation of a suitable insulation thickness allows this surface temperature to be equal to or greater than the dew, which will prevent condensation.

In addition to the data for calculating the surface temperature, we need the ambient air's relative humidity, which is sometimes not known or can only be estimated. The higher the relative humidity is, the more difficult it is to obtain a precise value, so fluctuations in humidity or surface temperature are determinant factors.

#### • For flat surfaces:

Using Table 1, we obtain the dew temperature  $T_d$ , which leaves the thickness  $d$  unknown when substituting:

$$[2.75] \quad d \geq \frac{\lambda}{h_e} \cdot \frac{T_d - T_i}{T_a - T_d}$$

where:

- $d$  flat surface thickness (m)
- $\lambda$  thermal conductivity of the material (W/mK)
- $h_e$  surface coefficient of heat transfer (W/m<sup>2</sup>K)
- $T_d$  dew temperature (°C)
- $T_i$  inside temperature (°C)
- $T_a$  ambient temperature (°C)

#### • For cylindrical walls:

The thickness ( $D_e = D_i + 2d$ ) appears inside and outside the logarithm so an iterative system needs to be used:

$$[2.76] \quad \frac{D_e}{2} \ln \frac{D_e}{D_i} \geq \frac{\lambda}{h_e} \cdot \frac{T_d - T_i}{T_a - T_d}$$

where:

- $D_e$  exterior cylindrical wall diameter (m)
- $D_i$  interior cylindrical wall diameter (m)
- $\lambda$  thermal conductivity of the material (W/mK)
- $h_e$  heat transfer by convection coefficient (W/m<sup>2</sup>K)
- $T_d$  dew temperature (°C)
- $T_i$  inside temperature (°C)
- $T_a$  ambient temperature (°C)

## 4. Special applications

### 4.1. Longitudinal temperature change in a pipe

To obtain the exact value of a fluid's temperature change along a pipe, the following equation is applied:

$$[2.77] \quad T_{fm} - T_a = (T_{im} - T_a)e^{-\alpha l}$$

where:

$T_{im}$  initial fluid temperature (°C)

$T_{fm}$  final fluid temperature (°C)

$T_a$  ambient temperature (°C)

$l$  length of the pipe (m)

where  $\alpha$  (m<sup>-1</sup>):

$$[2.78] \quad \alpha = \frac{U_i 3.6}{m C_p}$$

where:

$U_i$  linear thermal transfer (W/mK)

$m$  average mass flow (kg/h)

$C_p$  heat capacity at constant pressure (kJ/(kgK))

As, in practice, the acceptable temperature change is normally small, the following equation is applied for an approximate calculation:

$$[2.79] \quad \Delta T = \frac{q_l^* l \cdot 3.6}{m C_p}$$

where:

$\Delta T$  change in longitudinal temperature (°C)

$q_l^*$  linear density of the heat flow (W/m)

$l$  length of the pipe (m)

$m$  average mass flow (kg/h)

$C_p$  heat capacity at constant pressure (kJ/(kgK))

\* The linear density of flow can only be calculated if the average temperature of the fluid is known, which assumes that  $T$  must be known, for which it is necessary to use an iterative calculation method, starting from an estimated  $T$  value. The iterative procedure must be repeated as many times as necessary until the variation of  $T$  is acceptable.

### EXAMPLE 12: CALCULATION OF THE TEMPERATURE FALL OF A HOT STEAM PIPE

Determine the temperature fall of a fluid along a pipe, with the following boundary conditions:

- |   |                                  |
|---|----------------------------------|
| • Initial temperature   | $T_{im} = 250^{\circ}\text{C}$   |
| • Ambient temperature   | $T_a = -10^{\circ}\text{C}$      |
| • Pipe diameter   | $D_i = 0.1 \text{ m}$            |
| • Thickness of the insulation   | $e = 40 \text{ mm}$              |
| • average mass flow   | $\dot{m} = 45,000 \text{ kg/h}$  |
| • Thermal conductivity of the insulation between $250^{\circ}\text{C}$ and $25^{\circ}\text{C}$ | $\lambda = 0.061 \text{ W/(mK)}$ |
| • Length of the pipe  | $l = 2,000 \text{ m}$            |
| • Heat capacity   | $C_p = 2.233 \text{ kJ/(kgK)}$   |

The inside and outside surface coefficients are considered negligible in this example. This provides a linear density of the heat flow:

$$q = \frac{2\pi\lambda}{\ln \frac{D_e}{D_i}} (T_{st} - T_{sc}) = \frac{2\pi \cdot 0,061}{\ln \frac{0,180}{0,100}} (250 - (-10)) = 169.53 \text{ W/m}$$

To calculate the temperature fall more accurately, equation [2.77] is used:

$$T_{fm} - T_a = (T_{im} - T_a)e^{-\alpha l}$$

where :

$$\alpha = \frac{U_i 3.6}{m C_p}$$

where  $U_i$  is [Equation 2.78]:

$$U_i = \frac{q_l}{T_i - T_a} = \frac{169.53}{260} = 0.652 \text{ W/mK}$$

Therefore, the final temperature will be:

$$T_{fm} = T_a + (T_{im} - T_a)e^{-\alpha l} = -10 + (250 + 10)e^{-(2.33 \cdot 10^{-4} \cdot 2000)} = 238.16^{\circ}\text{C}$$

## 4.2. Change of temperature and cooling time in accumulators and tanks

The cooling time for a given temperature change is given by:

$$[2.80] \quad t_v = \frac{(T_{im} - T_a) \cdot (m \cdot C_p) \cdot \ln\left(\frac{T_{im} - T_a}{T_{fm} - T_a}\right)}{q \cdot 3.6 \cdot A} \cdot h$$

where:

- $t_v$  cooling time (h)
- $T_{im}$  initial fluid temperature (°C)
- $T_{fm}$  final fluid temperature (°C)
- $T_a$  ambient temperature (°C)
- $l$  length of the pipe (m)
- $U_i$  linear thermal transfer (W/mK)
- $q$  linear flow density (W/m<sup>2</sup>)
- $A$  surface of the accumulator or tank (m<sup>2</sup>)
- $m$  mass of the content (kg)
- $C_p$  heat capacity of the fluid in (kJ/kgK)

For a spherical deposit,  $q \cdot A$  is replaced by the heat flow rate  $\Phi_{sph}$ :

$$[2.81] \quad t_v = \frac{(T_{im} - T_a) \cdot (m \cdot C_p) \cdot \ln\left(\frac{T_{im} - T_a}{T_{fm} - T_a}\right)}{\Phi_{sph} \cdot 3.6} \cdot h$$

The exact calculation of the temperature fall as a function of time is formulated according to the following equation, similar to the change in longitudinal temperature, by varying  $l$  by  $t$  and  $\alpha$  by  $\alpha'$ :

$$[2.82] \quad T_{fm} - T_a = (T_{im} - T_a) e^{-\alpha' t}$$

where  $\alpha'$  is:

- For plane or cylindrical surfaces with  $D > 1$

$$[2.83] \quad \alpha'_s = \frac{U_i \cdot A \cdot 3.6}{m \cdot C_p}$$

- For pipes with fluid at rest

$$[2.84] \quad \alpha'_l = \frac{U_l \cdot l \cdot 3.6}{m \cdot C_p}$$

The temperature drop over time can be roughly calculated with the respective equations:

- For plane or cylindrical surfaces with  $D > 1$

$$[2.85] \quad \Delta T_s = \frac{q \cdot A}{m \cdot C_p} \cdot t \cdot 3.6$$

- For pipes with fluid at rest

$$[2.86] \quad \Delta T_l = \frac{q \cdot l}{m \cdot C_p} \cdot t \cdot 3.6$$

## 4.3. Calculation of freezing and cooling time of liquids at rest

It is impossible to prevent the cooling of a liquid in a pipe during an arbitrarily long unit of time, even if it is insulated.

As soon as the liquid (usually water) in the pipe is stationary, the freezing process begins.

The heat flow density  $q_i$  of a stationary liquid is determined by the energy stored in the liquid  $c_{pw} \cdot m_{pw}$ , and in the pipe material  $c_{pp} \cdot m_p$ , and also by the enthalpy required to transform water into ice.

If  $c_{pp} \cdot m_p \ll c_{pw} \cdot m_{pw}$  then  $c_{pp} \cdot m_p$  can be ignored.

### • Insulated pipes

The time until cooling starts is calculated according to the following expression:

$$[2.87] \quad t_v = \frac{(T_{im} - T_a) \cdot (m_p \cdot C_{pp} + m_w \cdot C_{pw}) \cdot \ln\left(\frac{T_{im} - T_a}{T_{fm} - T_a}\right)}{q_{wp} \cdot 3.6 \cdot A}$$

where:

- $t_v$  cooling time (h)
- $T_{im}$  initial fluid temperature (°C)
- $T_{fm}$  final fluid temperature (°C)
- $T_a$  ambient temperature (°C)
- $m_p$  pipe mass (kg)
- $m_w$  water volume (kg)
- $l$  length of the pipe (m)
- $C_p$  heat capacity (kJ/kgK)
- $q_{wp}$  flow density (W/m<sup>2</sup>)
- $A$  surface (m<sup>2</sup>)

where  $q_{wp}$ :

$$[2.8] \quad q_{wp} = \frac{\pi(T_{im} - T_a)}{2 \cdot \lambda \cdot \ln\left(\frac{D_2}{D_1}\right) + \frac{1}{h_e \cdot D_e}}$$

In insulated pipes, the outer surface thermal resistance will be negligible for the calculation of q. It can be used as the method indicated in Diagram 1.

Diagram 1. Determination of cooling times from 5 °C to 0 °C. The maximum allowed time for water in pipes of different diameters and with different insulation thicknesses to prevent water from cooling in a pipe. Initial water temperature = 5 °C, air velocity = 5 m/s, λ = 0.040 W/(mK), h<sub>e</sub> = 20 W/(mK).

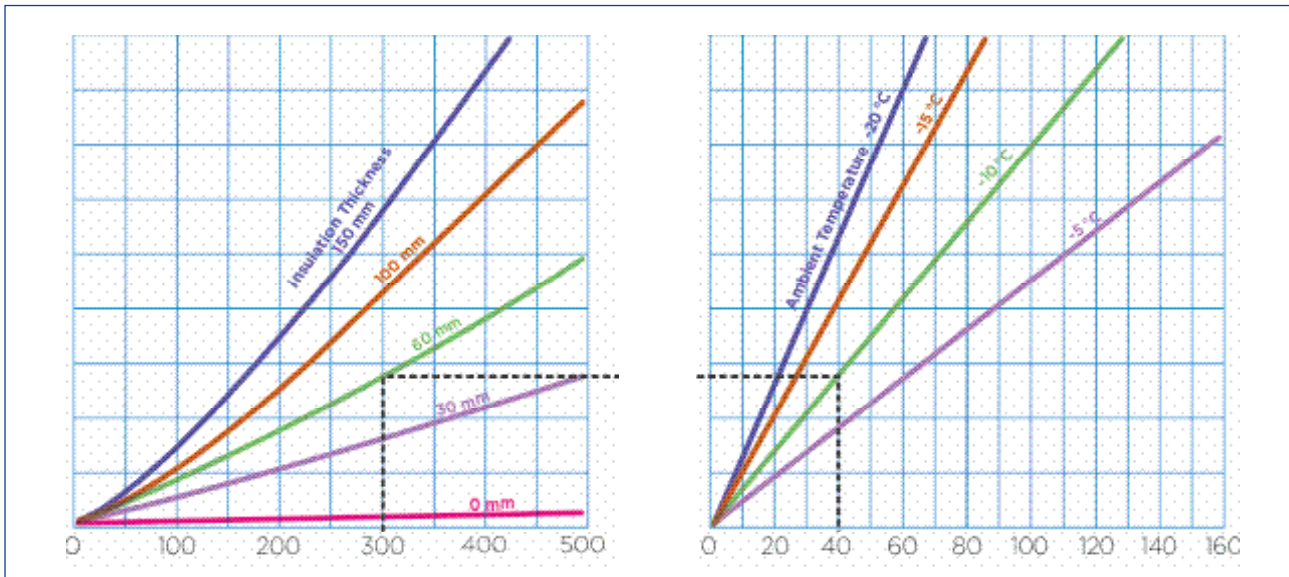

• Non-insulated pipes

If a comparison is made between insulated and non-insulated pipes, the influence of the non-insulated pipe's surface coefficient must be taken into consideration. The heat flow density of the non-insulated pipe is given by:

$$[2.89] \quad q_1 = h_e \cdot (T_{tm} - T_a) \cdot \pi \cdot D_e$$

As an approximation, the cooling time is given by:

$$[2.90] \quad t_p = \frac{(T_{tm} - T_a) \cdot (m_p \cdot c_{pp} + m_w \cdot c_{pw})}{q_{wp} \cdot 3.6 \cdot A}$$

For both cases, the cooling time is a function of the heat flow and

$$[2.91] \quad T_{fr} = \frac{f \cdot \rho_{ice} \cdot \pi \cdot D_i^2 \cdot h_{fr}}{100 \cdot q_{fr} \cdot 3.6 \cdot A}$$

where:

- T<sub>fr</sub> freezing time (h)
- D<sub>i</sub> inner pipe diameter (m)
- f percentage of water transferred to ice
- h<sub>fr</sub> specific enthalpy (latent heat of water cooling) = 334 kJ/kg
- ρ<sub>ice</sub> density of ice at 0 °C = 920 kg/m<sup>3</sup>
- q<sub>fr</sub> heat flow

• For an insulated pipe, being: (-T<sub>a</sub>)

$$[2.92] \quad q_{fr} = \frac{\pi \cdot (-T_a)}{\frac{1}{\lambda} \ln \frac{D_e}{D_i}}$$

where:

- q<sub>fr</sub> heat flow
- T<sub>a</sub> ambient temperature (°C)
- D<sub>e</sub> outer pipe diameter (m)
- D<sub>i</sub> inner pipe diameter (m)
- λ thermal conductivity (W/(mK))

## EXAMPLE 13: DETERMINING THE FREEZING AND COOLING TIME

Determine the freezing time to 0 °C and the partial cooling time of the water (25 % of the volume) under the following conditions:

- Water temperature
- Ambient temperature
- Inner diameter of the pipe
- Inner diameter of the insulation
- Thickness of the insulation
- Thermal conductivity of the insulation
- Heat of the water
- Latent cooling heat
- Specific heat of the water
- Density of the ice

$$\begin{aligned}
 T_{im} &= 20 \text{ °C} \\
 T_a &= -10 \text{ °C} \\
 D_{ip} &= 0.1 \text{ m} \\
 D_i &= 0.12 \text{ m} \\
 e &= 150 \text{ mm} \\
 &= 0.04 \text{ W/(mK)} \\
 m \cdot c_{pw} &= 26.7 \text{ kJ/K} \\
 h_{fr} &= 334 \text{ kJ/K} \\
 c_{pw} &= 4.2 \text{ kJ/(kgK)} \\
 &= 920 \text{ kg/m}^3
 \end{aligned}$$

The inside and outside surface coefficients are considered negligible in this example. This provides a heat flow:

$$q_{wp} = \frac{\pi(T_{im} - T_a)}{2 \cdot \lambda \cdot \ln \frac{D_a}{D_i}} = \frac{\pi(20 - (-10))}{2 \cdot 0.04 \cdot \ln \frac{0.42}{0.12}} = 6.018 \text{ W/(mK)}$$

The freezing time corresponding to the cooling point, without taking into account the heat capacity of the pipe, would be:

$$t_p = \frac{(T_{im} - T_a) \cdot (m_p \cdot c_{pp} + m_w \cdot c_{pw}) \cdot \ln \frac{(T_{im} - T_a)}{(T_{fm} - T_a)}}{q_{wp} \cdot 3.6 \cdot A} = \frac{30 \cdot 26.7 \cdot \ln \frac{30}{10}}{6.018 \cdot 3.6 \cdot 1} = 40.6 \text{ h}$$

The heat flow and cooling time of 25 % of the pipe volume would be:

$$q_{fr} = \frac{\pi(-T_a)}{2 \cdot \lambda \cdot \ln \frac{D_a}{D_i}} = \frac{\pi \cdot 10}{0.08 \cdot \ln \frac{0.42}{0.12}} = 2 \text{ W/m}$$

$$T_{fr} = \frac{f}{100} \cdot \frac{\rho_{ice} \cdot \pi \cdot D_i^2 \cdot h_{fr}}{q_{fr} \cdot 3.6 \cdot 4} = \frac{25}{100} \cdot \frac{920 \cdot \pi \cdot (0.1)^2 \cdot 334}{2 \cdot 3.6 \cdot 4} = 83.8 \text{ h}$$

#### 4.4. Underground pipes

They are considered underground pipes with or without thermal insulation either in channels or directly in the soil.

The thermal flow per linear metre of an underground pipeline is calculated using the equation:

$$[2.93] \quad q_{t,g} = \frac{T_i - T_{se}}{R_i + R_e}$$

where:

$T_i$  average temperature (°C)

$T_{se}$  surface temperature of the ground (°C)

$R_i$  thermal resistance for an underground and insulated pipeline (m k/W)

$R_e$  thermal resistance for a pipe in homogeneous soil (m k/W), expressed as:

$$[2.94] \quad R_g = \frac{1}{2\pi\lambda_g} \cdot \operatorname{arcosh} \frac{2 \cdot h_g}{D_i}$$

where:

$\lambda_g$  thermal conductivity of the soil (W/(mK))

$h_g$  distance between the centre of the pipe and the surface in (m)

Equation [2.94] can be simplified for  $h_g/D_i > 2$

$$[2.95] \quad R_g = \frac{1}{2\pi\lambda_g} \cdot \ln \frac{4 \cdot h_g}{D_i}$$

For pipes buried with insulation layers according to Figure 10, the thermal resistance is calculated according to the equation:

$$[2.96] \quad R_1 = \frac{1}{2\pi} \cdot \sum_{j=1}^n \left( \frac{1}{\lambda_j} \cdot \ln \frac{D_{e,j}}{D_{i,j}} \right)$$

The cross-section of the outside layer with an equivalent length (a) is taken into consideration with an equivalent diameter,  $D_n = 1,073 \cdot a$  (m).

The diameter  $D_i$  is identical to  $D_o$  (where  $j = 1$ ). In this case, the thermal resistance of the terrain  $R_e$  results in:

$$[2.97] \quad R_g = \frac{1}{2\pi\lambda_g} \cdot \operatorname{arcosh} \frac{2 \cdot h_g}{D_n}$$

where:

$R_e$  thermal resistance of the ground (mk/W)

$\lambda_g$  thermal conductivity of the soil (W/(mK))

$h_g$  distance between the centre of the pipe and the surface in (m)

There are calculation methods for determining the amount of heat flow and the ground temperature for other adjacent pipes.

In the case of lined pipes that are normally used, which are adjacent to each other, if  $h_g \ll h_{gE}$ , the calculation is usually sufficient as an initial approximation since the mutual effects can be neglected.

## 5. Thermal bridges

The supports, flanges, joints and other elements that form part of the insulation installation can constitute thermal bridges that suppose complementary losses and that are taken into account in a different way. For this, a differentiation first needs to be made between the ways of communicating the conductivity:

- **lab:** **thermal conductivity measured** in the laboratory
- **d:** **declared thermal conductivity** (declared and guaranteed by the manufacturer, as appears in the DoP (Manufacturer's Declaration of Performance))
- **o<sub>des</sub>:** **design thermal conductivity** (the conductivity that is taken into account for the calculations and in which the effects of the assembly are included).

### 5.1. Average thermal conductivity

The average thermal conductivity  $\lambda_m$  is measured using the following expression:

$$[2.98] \quad \lambda_m = \frac{1}{T_1 - T_2} \cdot \int_{T_2}^{T_1} \lambda(T) dT$$

where:

$\lambda$  thermal conductivity (W/(mK))

T temperature (°C)

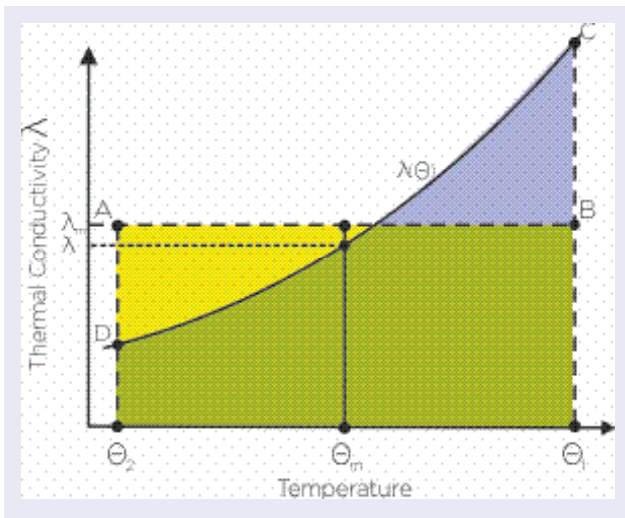

From the previous expression, it follows that:

$$[2.99] \quad \int_{T_2}^{T_1} \lambda(T) dT = \lambda_m \cdot (T_1 - T_2)$$

The average value of the integral  $\lambda_m$  is also called the average or effective thermal conductivity between  $T_1$  and  $T_2$ . The arithmetic mean of the temperature  $T_m = 0,5 (T_1 + T_2)$

### 5.2. Design thermal conductivity

Any calculation should be carried out with the design **thermal conductivity**  $\lambda_{des}$  (hereinafter  $\lambda$ ), which considers the influences of the assembly:

$$[2.100] \quad \lambda = \lambda_d \cdot F + \Delta\lambda$$

where:

$\lambda$  design thermal conductivity

$\lambda_d$  thermal conductivity declared by the manufacturer

F Correction factor

#### 5.2.1. Correction factor F

The correction factor **F** takes into account all the influences that may appear in the insulation assembly:

$$[2.101] \quad F = F_{\Delta T} \cdot F_m \cdot F_a \cdot F_C \cdot F_c \cdot F_d \cdot F_j$$

where:

$F_{\Delta T}$  correction of  $\lambda$  against the correction of  $\lambda_m$  for the operating temperature, together with the hot and cold surface temperatures

$F_m$  correction of the expected humidity content when the material is in equilibrium with a defined atmosphere

$F_a$  correction of the ageing effect according to the application, if it has not been included in the declared value

$F_C$  correction for the compression applied in the application

$F_c$  correction for the effect of convection inside the insulation material

$F_d$  correction for the effect of thickness

$F_j$  correction for the effect of open joints

The following table shows the approximate values of the global conversion factor F:

**Table of approximate values of the overall conversion factor F**

	Pipe horizontal/vertical		Wall horizontal/vertical, cavity filling without air gap or with vertical convection barrier <sup>d</sup>			Wall vertical; air gap on one side, no convection barrier <sup>d</sup>			Wall vertical without convection barrier <sup>d</sup> ; unavoidable air gap on the warm side			
Application												
Insulant Form of supply												
Mineral wool	Insulation											
	Ratio $d/D_N = 1$						Airflow resistivity 30 kPa·s/m <sup>2</sup>					
Wired mesh mat Board (only plane application)	Layers	Mean temperature		Layer	Mean temperature		Layer	Mean temperature		Layer	Mean temperature	
		50°C	300°C		50°C	300°C		50°C	300°C		50°C	300°C
	one <sup>a</sup>	1.10	1.05	one <sup>a</sup>	1.10	1.20	one <sup>a</sup>	1.20	1.05	one <sup>a</sup>	1.80	1.40
	two <sup>b</sup>	-	1.05	two <sup>b</sup>	-	1.15	two <sup>b</sup>	-	1.25	two <sup>b</sup>	-	1.60
	several <sup>c</sup>	-	1.00	several <sup>c</sup>	-	1.10	several <sup>c</sup>	-	1.30	several <sup>c</sup>	-	1.60
	Ratio $d/D_N = 0,5$						Airflow resistivity 50 kPa·s/m <sup>2</sup>					
	Layers	Mean temperature					Layer	Mean temperature		Layer	Mean temperature	
		50°C	300°C					50°C	300°C		50°C	300°C
	one <sup>a</sup>	1.10	1.10				one <sup>a</sup>	1.15	1.20	one <sup>a</sup>	1.40	1.30
	two <sup>b</sup>	-	1.10				two <sup>b</sup>	-	1.20	two <sup>b</sup>	-	1.40
	several <sup>c</sup>	-	1.05				several <sup>c</sup>	-	1.20	several <sup>c</sup>	-	1.35
							Airflow resistivity 70 kPa·s/m <sup>2</sup>					
						Layer	Mean temperature		Layer	Mean temperature		
							50°C	300°C		50°C	300°C	
						one <sup>a</sup>	1.15	1.20	one <sup>a</sup>	1.60	1.30	
						two <sup>b</sup>	-	1.20	two <sup>b</sup>	-	1.30	
						several <sup>c</sup>	-	1.15	several <sup>c</sup>	-	1.25	

<sup>a</sup> Equivalent of an insulation thickness of 100 mm.  
<sup>b</sup> Equivalent of an insulation thickness of 200 mm.  
<sup>c</sup> Equivalent of an insulation thickness of 300 mm.  
<sup>d</sup> With application of air-tight insulation.

### 5.2.2. Increments of $\Delta$

For the components of the insulation layer that are thermal bridges with regular separation related to the insulation, such as the spacers, their influence is taken into account adding  $\Delta$  to the declared thermal conductivity that has already been corrected (applying the F factor).

$\Delta$  depends on different variables and they differ according to each application, but the following values could be taken as an approximate reference for common layer thicknesses (between 100 and 300 mm):

- |                                     |                                       |
|-------------------------------------|---------------------------------------|
| • Steel spacers                     | $\Delta = 0.010 \text{ W/(mK)}$       |
| • Austenitic steel spacers          | $\Delta = 0.004 \text{ W/(mK)}$       |
| • Ceramic spacers                   | $\Delta = 0.003 \text{ W/(mK)}$       |
| • Steel spacers in form of flat bar |                                       |
| • 30 mm x 3 mm                      | $\Delta_{sq} = 0.0035 \text{ W/(mK)}$ |
| • 40 mm x 4 mm                      | $\Delta_{sq} = 0.0060 \text{ W/(mK)}$ |
| • 50 mm x 5 mm                      | $\Delta_{sq} = 0.0085 \text{ W/(mK)}$ |

The equation  $\Delta$  to be considered for the spacers for metal wall claddings depends on the number of separators per square metre (m<sup>2</sup>) according to the formula:  $\Delta = N\Delta_{sq}$

On the other hand, the components of the insulation layer, such as supports, frames, etc., which have an irregular separation, are considered as additional heat losses.

## 6. General rules related to the installation

### 6.1. Equivalent lengths

To calculate energy losses in valves and flanges, the term equivalent length can be used, for both flanges and valves.

As a general rule, an equivalent length of 0.5 m for the flanges is considered for the length of a pipe of the same diameter, and 1.0 metre for the valves.

If you would like further details on this topic, please refer to Table A.1 "Equivalent length for "thermal bridges" related to the installation" of the ISO 12241 (2008) standard, as well as the VDI 4610 standard.

The following examples for a flange DN 125 and valve DN 150 give us an idea of the equivalent length of these elements.

#### FLANGE DN 100

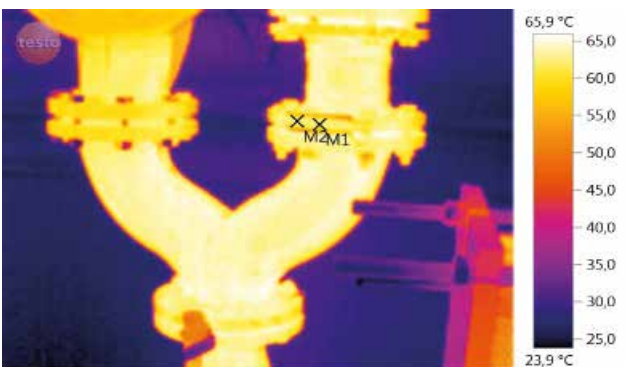

For a non-insulated DN 100 flange, and with a fluid temperature of 70 °C, the heat flow in the flange that is measured with a heat flow meter, and knowing its surface, gives us a loss of 110 W/element. This corresponds to around 0.48 m of a non-insulated DN 100 pipe.

We understand that it is possible to approximate the energy losses of a flange to the losses of a pipe of the same diameter with an equivalent length of 1.0 m.

#### VALVE DN 80

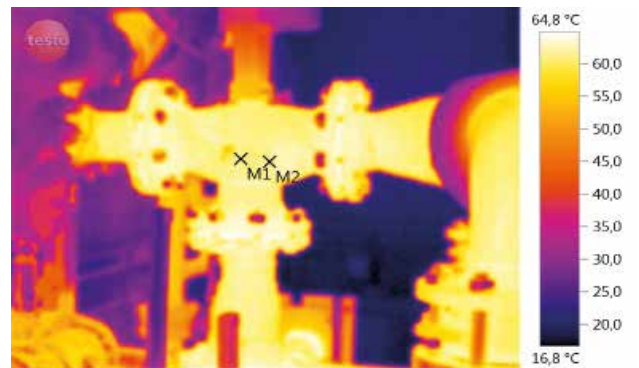

For a non-insulated DN 80 valve with a fluid temperature of 70 °C, the heat flow in the valve is measured with a heat flow meter, and knowing its surface, gives us a loss of 172 W/valve. This corresponds to around 0.97 m of a non-insulated DN 80 pipe.

We understand that it is possible to approximate the energy losses of a valve to the losses of a pipe of the same diameter with an equivalent length of 1.0 m.

### 6.2. Energy losses in supports and suspensions

To calculate energy losses, as a general rule and due to suspensions and supports, the total losses can be increased by a percentage depending on whether they are indoors or outdoors.

For indoors: increase the losses of the pipe by 15 %.

For outdoors: increase the losses of the pipe by 25 %.

For further details on this subject, please refer to the ISO 23993 standard.

## 3. Energy Efficiency





1.	Current situation .....	90
1.1.	<b>Sector-by-sector breakdown of energy consumption in Europe.....</b>	<b>90</b>
2.	Applicable standards.....	91
3.	Why make savings through insulation?.....	91
4.	Potential energy saving through insulation.....	92
5.	Steps to follow to achieve energy-saving potential .....	93
5.1.	<b>Step 1 Insulate uninsulated or damaged parts .....</b>	<b>93</b>
5.2.	<b>Step 2 Assess cost-effective insulation and consider energy-efficient cost .....</b>	<b>93</b>
5.3.	<b>Step 3 Involve insulation experts in the initial stages of projects and new builds .....</b>	<b>94</b>
6.	Real examples from industry.....	94
6.1.	TIPCHECK Glass wool manufacture.....	95
6.2.	TIPCHECK Stone wool manufacture.....	96
6.3.	TIPCHECK Ceramics industry .....	97
6.4.	TIPCHECK Automotive industry .....	98

### 3. Energy Efficiency

#### 1. Current situation



The cleanest and most economical energy is energy that is not consumed at all.

Energy efficiency is an essential aspect of Europe's 2020 strategy for sustainable growth, and one of the most cost-efficient ways of strengthening energy security and reducing emissions of greenhouse gases and other pollutants.

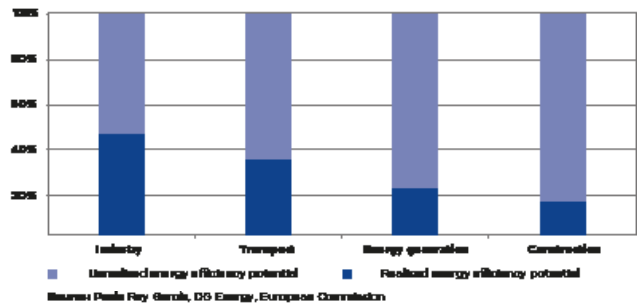

When it comes to energy efficiency, we are trailing behind the residential sector. Whereas in a newly built home the Building Code obliges us to keep energy losses to no more than 10 W/m<sup>2</sup>, there are no mandatory standards limiting energy losses in industry.

#### 1.1. Sector-by-sector breakdown of energy consumption in Europe

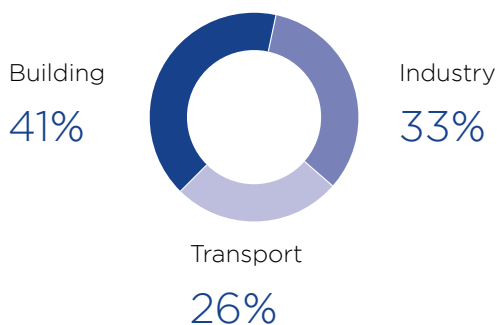

	Energy plant	Current Building Code	Passive house
Temperature (°C)	250 – 640	18 – 22	18 – 22
Energy losses (AGI Q101) (W/m <sup>2</sup> )	150*	< 10	< 3
Insulation thickness (mm)	100	100	350–500

In Europe, the construction sector is the number one energy consumer, followed by industry and transport.

(\* ) Usual losses are many times higher than this value in industrial sites

## 2. Applicable standards

Energy efficiency standards exist that aim to arouse interest in energy-efficient processes and help businesses acquire the skills necessary to identify and implement energy-saving measures. Foremost among them are:

### Standard EN ISO 50001 on Energy Management Systems

An international standard aiming to help organisations to establish the systems and processes necessary to improve their energy performance. It is based on the Continuous Improvement Management System model:

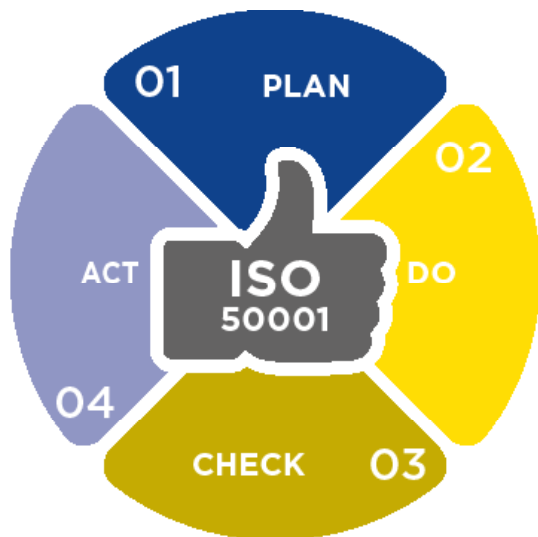

### European Directive 2012/27/EU

The European Energy Efficiency Directive (Directive 2012/27/EU of the European Parliament and the Council of 25 October 2012) on energy audits provides the accreditation rules of service providers and efficiency of energy supply.

#### What obligations does it impose?

To undergo an energy audit every 4 years or, alternatively, to install energy management systems.

#### What companies are affected?

Companies with more than 250 staff or revenue in excess of 50 million.

Penalties of up to 80,000 are to be imposed for failure to meet these obligations.

- PLAN** Establish an Energy Plan for the organisation, setting out concrete actions and objectives to improve the organisation's energy management and Energy Policy.
- DO** Implement the actions set out in the plan established by the management.
- CHECK** Monitor the results, establishing suitable indicators to determine the extent to which objectives have been met and the plan adhered to, so that the results can be properly assessed and shared.
- ACT** Review the results and implement the corrections and improvements deemed necessary, so that the results can be properly assessed and shared.

## 3. Why make savings through insulation?

Often, the pre-requisites for cost-efficiency and the maximum energy-efficiency of an insulation system are not considered. In the past, when oil prices were lower, a facility's energy efficiency did not make such a big difference. Today, energy prices are much higher and

are expected to keep on increasing. For this reason, the gap between current insulation and cost-efficient insulation is widening. Additional costs for CO<sub>2</sub> emitters are making these potential savings more immediate.

### Here are the reasons why insulation is essential in industry

- **Energy saving:** The aim is to reduce the amount of energy required to keep the process in equilibrium and avoid heat flow through the material. This is achieved by installing insulation to reduce heat losses.
- **Surface temperature - Protection of personnel:** If there is insufficient thermal insulation, the external surface temperatures can be high, causing accidents and injuries.
- **Process conditions:** In any process, it is important to avoid heat transfers that cause the process to dysfunction due to unacceptable temperature differences. This thermal stability is achieved through insulation.
- **Environmental impact:** Insulation reduces the amount of energy required and thus reduces CO<sub>2</sub> emissions, as most of the energy used in thermal processes comes from the burning of a fuel.



## 4. Potential energy saving through insulation

According to the **Ecofys** study conducted by the EiiF (European Industrial Insulation Foundation) in May 2014, checks carried out by experts on industrial plants showed that at least 10% of facilities are not insulated, or are, but contain insulation in a poor state of repair.

In addition, the insulation installed is usually selected with the aim of keeping investment costs to a minimum, and takes account solely of the surface temperature to avoid personal injury, the minimum requirements of the industrial process, or the generic average heat losses.

**In Spain, the potential annual energy saving is 49 PJ and 3.4 million tonnes of CO<sub>2</sub>, which means:**



x100,000  
The energy consumption of 1,200,000 homes

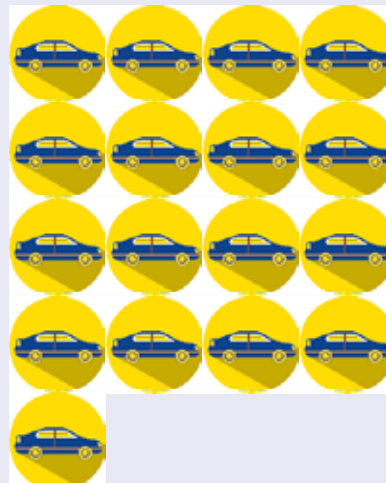

x100,000  
The CO<sub>2</sub> emissions of 1,700,000 cars (based on mileage of 12,500km a year)

Much of this potential could be achieved through investments that would be paid back within a year. Insulating uninsulated parts and repairing damaged insulation would require an investment of 75 million. This investment would enable 70% of total potential to be achieved, which would mean an annual saving of 400 million.

**Source: 2014 Ecofys study.**

## 5. Steps to follow to achieve energy saving potential

### 5.1. Step 1 Insulate uninsulated or damaged parts

**Insulate uninsulated or damaged parts (this is where the greatest potential lies, with payback in less than a year).**

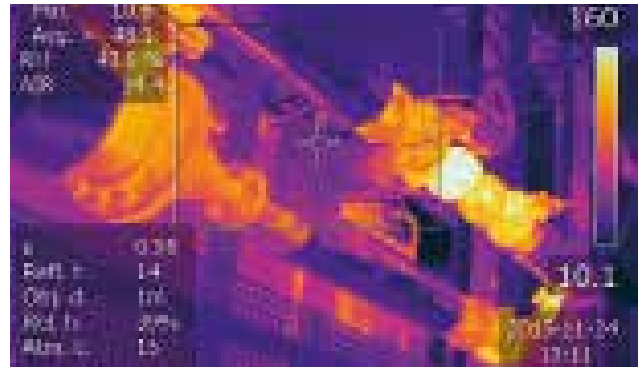
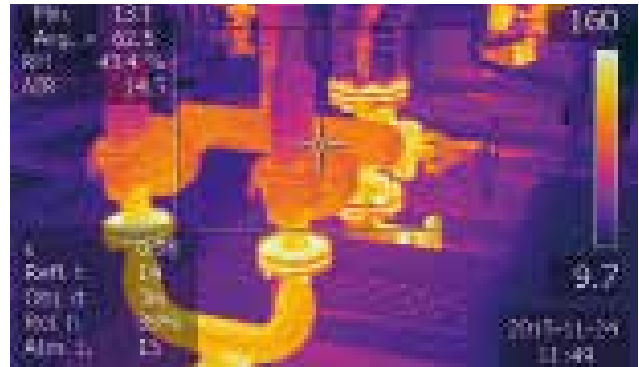

### 5.2. Step 2 Assess cost-effective insulation and consider energy-efficient cost

**Assess cost-effective insulation and consider energy-efficient cost.**

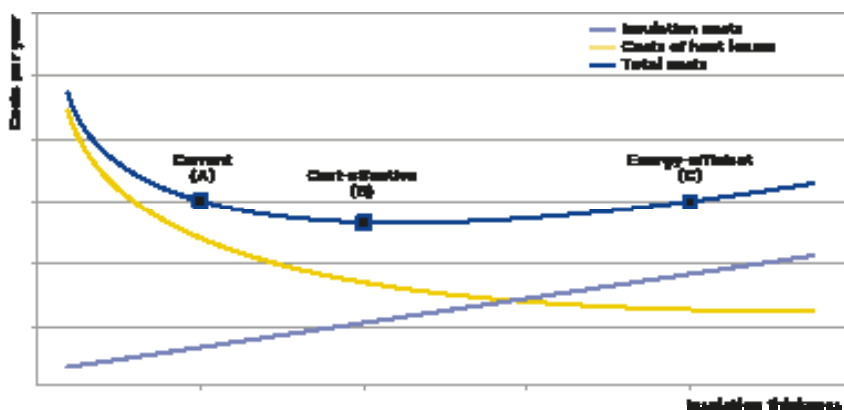

ISOVER markets TechCalc, thermal calculation software that performs all the calculations mentioned in Standard UNE-EN-ISO 12241, including some as important as calculating the optimum thickness.

**Factors influencing energy efficiency (in decreasing order of influence)**

1. (of the insulating material)
2. Thickness
3. Thermal bridges
4. Cladding emissivity

### 5.3. Step 3 Involve insulation experts in the initial stages of projects and new builds

#### Involve insulation experts in the initial stages of projects and new builds.

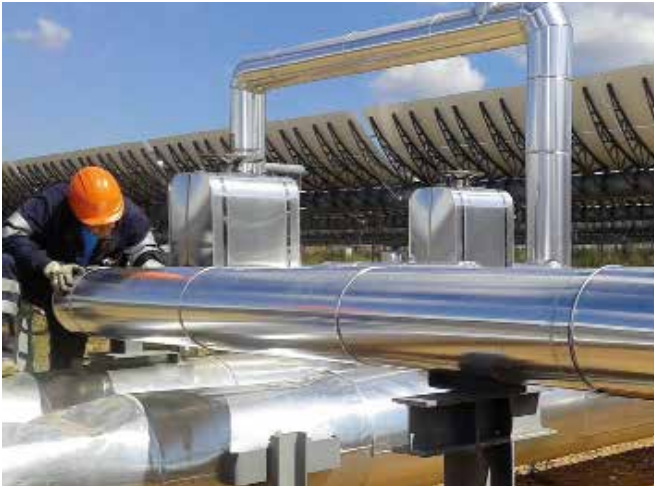

Often, the reason why efficient insulation cannot be implemented is that insufficient space is available. Insulation experts help avoid planning errors.

TIPCHECK (Technical Insulation Performance Check) Engineers, certified by the EiiF (European Industrial Insulation Foundation) perform independent energy assessments and calculate the potential cost and energy savings. Through insulation, TIPCHECK assesses the insulation systems of existing facilities, projects or maintenance operations and shows how more efficient thermal insulation could save energy and costs and contribute to cleaner production by reducing CO<sub>2</sub> emissions.

The best way of detecting potential energy savings through insulation in an industrial plant is through **Energy Audits**. Often, when we talk about Energy Audits, we focus on replacing variable speed drives with starters, and installing smart, energy-efficient

lighting, but we should not lose sight of the fact that, if the process components are not properly insulated, we will be losing energy constantly, making them an important source of potential savings.

## 6. Real examples from industry

Around the world, Saint-Gobain ISOVER has nine TIPCHECK Engineers who offer their services to customers in relation to TIPCHECK audits and provide advice on detecting energy-efficiency improvements through insulation.

ISOVER's total commitment to this initiative is demonstrated by its development of an internal programme called TIP-4-BEST, the aim of which is to reduce losses connected with energy consumption by one-quarter. This programme has been

incorporated in the Energy pillar of the WCM (World Class Manufacturing) programme, meaning a TIPCHECK audit will be performed at all Saint-Gobain plants, ultimately leading to improvements in the maintenance plan and the subsequent checking of results.

The following are examples of TIPCHECK audits, performed both within the Saint-Gobain Group and for external customers, to check the results of implementing insulation improvement measures.

## 6.1. TIPCHECK Glass wool manufacture



**Performed 2018**

Plant: **Saint-Gobain ISOVER**, Yegorievsk - Russia

Activity: **Glass wool manufacture**, Curing oven



Two curing ovens of the production lines at Saint-Gobain ISOVER in Yegorievsk, Russia. The main function of the curing oven is raise the temperature of the glass wool to make the binder inside polymerizing. The total length of this element is around 53 m.

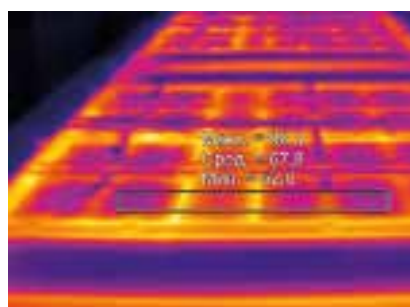
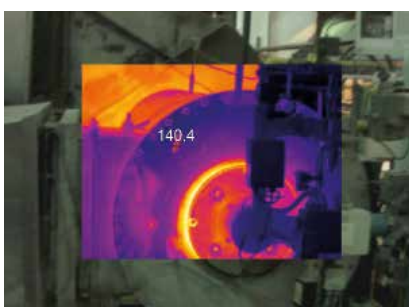
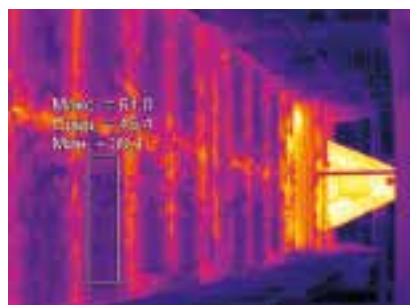
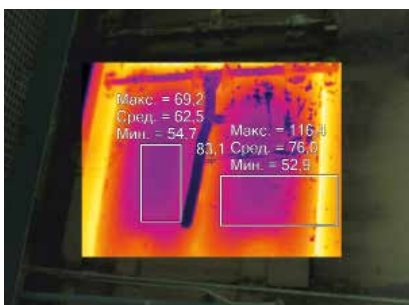

Saving achieved by improving the existing insulation of the kiln roof	
Investment	7,015
Payback	2.1 years
Economic savings	3,217 per year
Energy savings	256 MWh per year
CO <sub>2</sub> reduction	54 T per year

## 6.2. TIPCHECK Stone wool manufacture



**Performed 2018**

Plant: **Saint-Gobain ISOVER**, Genouillac - France

Plant activity: **Stone wool manufacture**, Curing oven and air heating system

The curing oven and air heating system to the cupola of the production line at Saint-Gobain ISOVER in Genouillac, France. The main function of the curing oven is to raise the temperature of the glass stone to make the binder inside polymerizing. The air heating system raises the air temperature before being introduced in the combustion area of the cupola furnace.



Saving achieved by improving the existing insulation of the kiln roof	
Investment	128,026
Payback	3.1 years
Economic savings	41,415 per year
Energy savings	1,718 MWh per year
CO <sub>2</sub> reduction	430 T per year

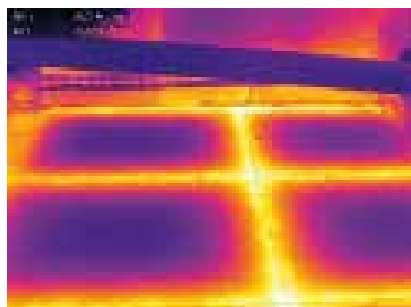
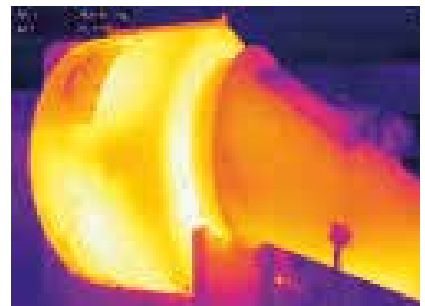

## 6.3. TIPCHECK Ceramics industry

**Performed 2017**

Plant: **Comain, Carros y Maquinaria cerámica (www.comain.es).**  
**Almassora plant.**

Plant activity: **Auxiliary work for the ceramics industry.**  
 Part of process audited: **Ceramics kiln.**



The ceramics kiln is a flexible and innovative production unit, composed of prefabricated modules, clad with light fire bricks and thermal insulation. Equipped with modern kiln control and truck monitoring systems, the kiln is used for first firing, high-temperature ceramic firing, bisque firing and glaze firing, creating the ideal temperature profile for the ceramic material.

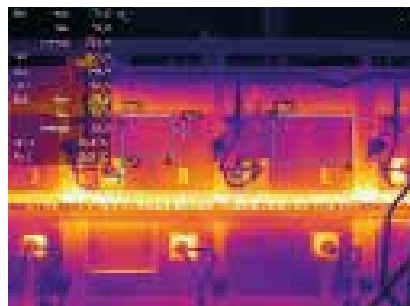
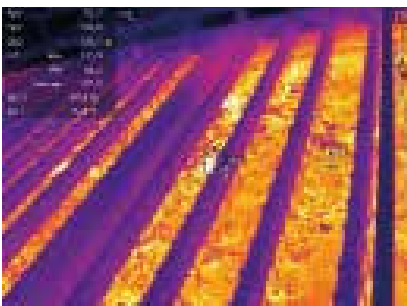

**Saving achieved  
 by improving the existing insulation  
 of the kiln roof**

Investment  
 9,650

Payback  
 2.1 years

Economic savings  
 59,963 per year

Energy savings  
 1,602 MWh per year

CO<sub>2</sub> reduction  
 43,171 T per year

## 6.4. TIPCHECK Automotive industry



**RENAULT**

This furnace is used for the heat treatment of metal parts for the automotive industry. The term "heat treatment" refers to all heating and cooling operations (with controlled temperature conditions, dwell time, velocity, pressure, etc.) of metals or alloys in a solid state, with the aim of improving their mechanical properties, especially their hardness, resistance and elasticity.

**Performed 2018**

Plant: **Renault. Aveiro plant.**

Plant activity: **Automotive industry.**

Part of process audited: **Tempering furnace.**

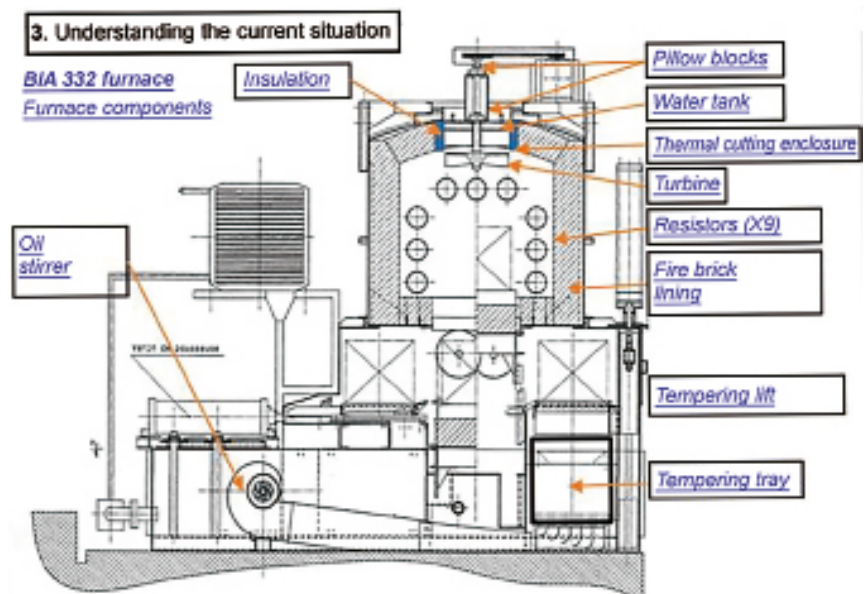

**Saving achieved**  
by improving the existing insulation  
of the kiln roof

Investment  
**6,000**

Payback  
**4.90 months**

Economic savings  
**14,700.85 per year**

Energy savings  
**171.38 MWh per year**

CO<sub>2</sub> reduction  
**57.70 T per year**

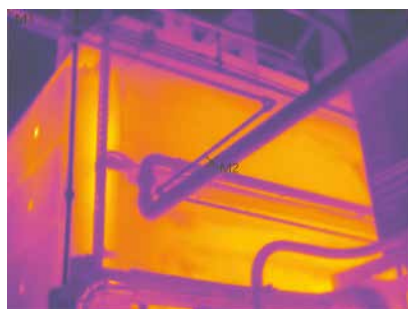

# TechCalc 2.0

## Thermal calculation software

- Calculations as per ISO 12241
- Intuitive interface
- Available in different languages
- Suitable for mobile devices
- Online version also available



Building your future

## 4. Thermal Insulation Techniques



1	ISOVER TECH range.....	102	3	Installation guidelines .....	132
1.1	<b>Insulation solutions for pipework.....</b>	<b>102</b>	3.1	<b>Introduction.....</b>	<b>132</b>
	1.1.1 Insulation with ISOVER		3.2	<b>Occupational health, safety and</b>	
	Tech Pipe sections.....	102		<b>risk prevention .....</b>	<b>132</b>
	1.1.2 ISOVER tech insulation solutions		3.3	<b>Preliminary and general observations .....</b>	<b>132</b>
	for big diameter pipe.....	103	3.4	<b>Insulation systems for pipes .....</b>	<b>134</b>
1.2	<b>Insulation solutions for storage tanks .....</b>	<b>105</b>	3.4.1	Straight sections. One layer of insulation	
	1.2.1 Insulation of tank walls.....	105		Pipe Section Solution	
	1.2.2 Insulation of tank roofs and			Wired Mat Solution	
	higher temperature surfaces.....	106		Pipe Section Mat Solution .....	134
1.3	<b>Insulation solutions for boilers,</b>		3.4.2	Straight sections.	
	<b>exhaust ducts and stacks .....</b>	<b>107</b>		Two or more layers of insulation .....	136
1.4	<b>Insulation solutions for special</b>		3.4.3	Curved sections.	
	<b>industry applications.....</b>	<b>108</b>		Insulation of elbows.....	137
	1.4.1 ISOVER CRYOLENE -		3.4.4	Flanges and valves.....	138
	Insulation for cryogenic tanks .....	108	3.4.5	Pipes with tracing systems.....	139
	1.4.2 ISOVER TECH "QN"-		3.4.6	Other pipe components .....	141
	Insulation solutions in Nuclear				
	Quality .....	109	3.5	<b>Insulation systems for equipment</b>	
	1.4.3 ISOVER "EX"-			<b>and tanks .....</b>	<b>143</b>
	insulation solutions for		3.6	<b>Quality inspection plan.....</b>	<b>152</b>
	Explosion Risk Areas.....	110	3.6.1	Piping.....	152
			3.6.2	Equipment.....	153
			3.6.3	Works supervision.....	155
2	Applications and drawings .....	111			
2.1	<b>Thermal Energy Storage - Salt Tanks -</b>		4	<b>Corrosion Under</b>	
	<b>Wired Mats Solution .....</b>	<b>112</b>		<b>Insulation (CUI).....</b>	<b>156</b>
2.2	<b>Thermal Energy Storage - Salt Tanks -</b>		4.1	<b>Definitions .....</b>	<b>156</b>
	<b>Slabs Solution .....</b>	<b>114</b>	4.1.1	Humidity, moisture.....	156
2.3	<b>Thermal Energy Storage - Sewage Tanks -</b>		4.1.2	Absolute and relative humidity.....	156
	<b>Wired Mats / Rolls Solution.....</b>	<b>116</b>	4.1.3	Water vapour transmission.....	156
2.4	<b>Thermal Energy Storage</b>		4.1.4	Condensation and dew point .....	156
	<b>Oil Buffer Storage Tanks - Slabs Solution...</b>	<b>118</b>	4.2	<b>Insulation products behaviour .....</b>	<b>157</b>
2.5	<b>Big size Pipes - Superheated Steam Pipe -</b>		4.2.1	Wet insulation performance.....	157
	<b>Wired Mats / PSM Solution.....</b>	<b>120</b>	4.2.2	Water ingress.....	157
2.6	<b>Mid Size Pipes - Mid Temperature</b>		4.3	<b>Corrosion Under Insulation (CUI).....</b>	<b>158</b>
	<b>District heating - Pipe section and</b>		4.3.1	What is CUI? .....	158
	<b>Wired Mats (two layers) .....</b>	<b>122</b>	4.3.2	Critical conditions and what to do .....	159
2.7	<b>Mid Size Pipes - High Temperature</b>		4.3.3	Protection of the metal.....	159
	<b>Steam Reformer Pipe - Pipe section and</b>		4.3.4	Installation of the insulation system ....	160
	<b>Wired Mats (two layers) .....</b>	<b>124</b>	4.3.5	Maintenance.....	160
2.8	<b>Small Size Pipes - Low Temperature</b>				
	<b>Hot Water Pipe - Pipe section .....</b>	<b>126</b>			
2.9	<b>Valve insulation - Mid Temperature</b>				
	<b>Oil process - Mattresses .....</b>	<b>128</b>			
2.10	<b>Flange insulation - Mid Temperature</b>				
	<b>Oil process - Mattresses .....</b>	<b>130</b>			

# 1 ISOVER TECH Range - Complete industry product range

**ISOVER TECH products not only provide high levels of thermal performance for economic and environmental purposes, they are designed to operate at a range of temperatures up to 700°C (MST), provide excellent acoustics to help controlling plant noise, and improve safety for plant personnel. They are light and easy to handle, and are particularly beneficial where access is difficult and space limited.**



## 1.1 Insulation solutions for pipework

### 1.1.1 Insulation with ISOVER TECH Pipe Sections

ISOVER offers a range of TECH Pipe Sections in glass wool, stone wool and ULTIMATE to adapt to different temperatures and needs of industry pipe insulation. ISOVER TECH Pipe Sections can normally all be used without support structures and have a beneficial length of 1,200 mm for fast and efficient installation.

Please refer to local standards and insulation specifications for detailed installation guidelines.

ISOVER TECH Pipe Sections	in glass wool	in stone wool	in ULTIMATE
<b>Key features</b>	light	robust	high performance at low weight
<b>Max. thermal use</b>	up to 500 °C	up to 650 °C	up to 660 °C
<b>Max. efficiency class</b>	4. Standard plus	4. Standard plus	4. Standard plus
<b>Key products</b>	TECH Pipe Section MT 4.0 / MT 4.2	TECH Pipe Section MT 4.1	U TECH Pipe Section MT 4.0



### 1.1.2 ISOVER TECH insulation solutions for big diameter pipe

#### Flexible insulation with support structure

The standard method used for flexible insulation of big diameter process pipes, irrespective of the pipe diameter, is usually the installation of wired mats.

ISOVER offers a range of standard stone wool wired mats of different densities and thermal performances.

ISOVER U TECH Wired Mats in ULTIMATE are the energy-efficient alternative to standard wired mats.

Both are stitched with stainless or galvanised wire on galvanised or stainless wire mesh and can be joined and sealed by wire, hooks or rings.



(U) TECH Wired Mats	in stone wool	in ULTIMATE
<b>Key features</b>	flexible and proven	high performance at low weight
<b>Max. thermal use</b>	up to 680 °C	up to 700 °C
<b>Max. efficiency class</b>	6. Premium plus	8. Extra plus
<b>Key products</b>	TECH Wired Mat MT 3.0/3.1, MT 4.0/4.1 MT 5.0/5.1, MT 6.1	U TECH Wired Mat MT 4.0, MT 5.0, MT 6.0, MT 7.0, HT 8.0



**Flexible insulation without support structures**

As the standard method used for flexible insulation of big diameter process pipes ISOVER offers two flexible pipe insulation alternatives that do not require installation with support structures due to their exceptional compressive strength:

Compression-resistant Lamella Mats in glass- and stone wool can be used irrespective of the pipe diameter.

ULTIMATE Pipe Section Mats (PSM) are high-performance V-grooved slabs adapted to the pipe diameter and are delivered flat-packed to save transport costs and space.



(U) TECH	Compression resistant Lamella Mats	ULTIMATE Pipe Section Mats (PSM)
<b>Key features</b>	flexible, compressive strength $\geq 10$ kPa	high performance at low weight
<b>Max. thermal use</b>	up to 620 °C	up to 700 °C
<b>Max. efficiency class</b>	2. Classic plus	7. Extra
<b>Key products</b>	TECH Lamella Mat 2.0, MT 2.1	U TECH PSM MT 7.0 G1

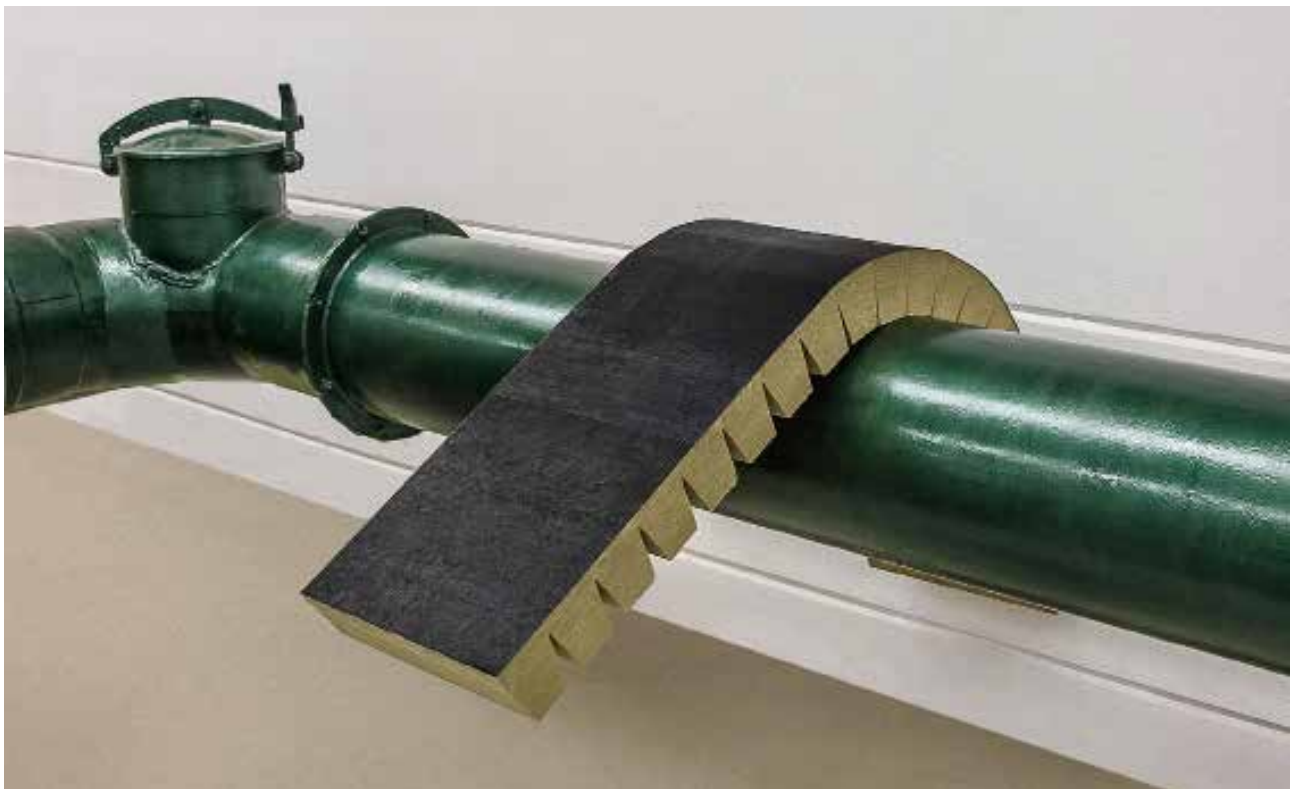

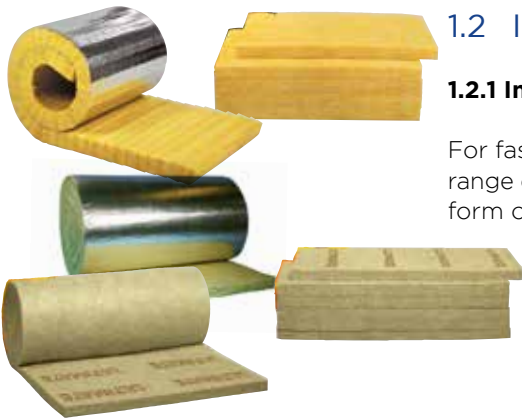

## 1.2 Insulation solutions for storage tanks

### 1.2.1 Insulation of tank walls

For fast and efficient insulation of tank walls ISOVER has created a wide range of light and flexible but also mechanically-improved solutions in the form of TECH rolls, crimped rolls, lamella mats and slabs.

(U) TECH	TECH Crimped Rolls in glass wool	TECH Lamella Mats in glass wool	TECH Slabs in glass wool	U TECH Rolls in ULTIMATE	U TECH Slabs in ULTIMATE
<b>Key features</b>	flexible, crimped rolls for fast, light and easy installation	high mechanical strength and flexibility combined	robust, fast to use	flexible, light and efficient alternative	light, efficient and easy to handle
<b>Max. thermal use</b>	up to 350 °C	up to 400 °C	up to 400°C	up to 460 °C	up to 440 °C
<b>Max. efficiency class</b>	2. Classic plus	2. Classic plus	3. Standard	4. Standard plus	3. Standard
<b>Key products</b>	TECH Crimped Roll 1.0, 2.0	TECH Lamella Mat 2.0	TECH Slab 2.0, 3.0	U TECH Roll 2.0, MT 4.0	U TECH Slab 2.0, MT 3.0/3.1



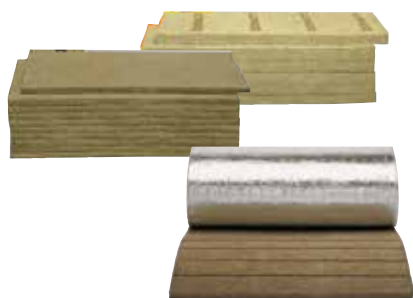

### 1.2.2 Insulation of tank roofs and higher temperature surfaces

For applications with high demands in terms of temperature resistance and compressive strength such as in tank roof constructions ISOVER provides high-density TECH slabs and the thermally-efficient range of medium to high-temperature U TECH slabs in ULTIMATE quality.

(U) TECH	TECH Lamella Mats in stone wool	ISOVER TECH Slabs in stone wool	ISOVER U TECH Slabs in ULTIMATE
<b>Key features</b>	flexible, compressive strength ≥ 10 kPa	robust, high compressive strength slabs	light, thermally efficient alternative
<b>Max. thermal use</b>	up to 620 °C	up to 700 °C	up to 700 °C
<b>Max. efficiency class</b>	2. Classic plus	6. Premium plus	8. Extra plus
<b>Key products</b>	TECH Lamella Mat MT 2.1	TECH Slab MT 4.0, 4.1, 5.0, 5.1	U TECH Slab MT 6.0, MT 7.0, HT 8.0



### 1.3 Insulation solutions for boilers, exhaust ducts and stacks

**Higher temperature equipment such as boilers and vessels have their own demands with regard to insulation design, especially with regard to maximum service temperature limits, thermal insulation performance but also resistance to temperature shocks, flexibility, chemical behaviour and many more.**

To answer these demands, ISOVER has designed the flexible TECH Wired Mat product range in stone wool and for more efficiency and light weight constructions the U TECH Wired Mat product family. Additionally, TECH Loose Wool fills any gap remaining.



(U) TECH	TECH Wired Mats in stone wool	U TECH Wired Mats in ULTIMATE	TECH Loose Wool in stone wool
<b>Key features</b>	flexible and long-term proven	high thermal performance, light and space saving	flexible, with low or no binder
<b>Max. thermal use</b>	up to 680 °C	up to 700 °C	up to 700 °C
<b>Max. efficiency class</b>	6. Premium plus	8. Extra plus	–
<b>Key products</b>	TECH Wired Mat MT 3.0/3.1, MT 4.0/4.1, MT 5.0/5.1, MT 6.1	U TECH Wired Mat MT 4.0, MT 5.0, MT 6.0, MT 7.0 and HT 8.0	TECH Loose Wool HT, TECH Loose Wool EX



## 1.4 Insulation solutions for special industry applications

### 1.4.1 ISOVER CRYOLENE - Insulation for cryogenic tanks

Design specifications for storage tanks holding cryogenic fluid such as liquefied natural gas (LNG), liquid oxygen or nitrogen for chemical or combustion processes are highly demanding not only in terms of construction, but also in terms of the insulation systems used. With the tank volume expanding and contracting depending on the level of liquid inside, the insulation must offer high levels of both compressibility and resilience.

To meet this requirement, ISOVER has developed the unique CRYOLENE solution for the insulation of cryogenic tank walls and roofs.

CRYOLENE products are highly resilient mineral wool rolls designed to retain their fibre elasticity at long term at temperatures ranging from -170 °C to +120 °C. Different solutions have been developed for tank shells and suspended deck insulation. The product's extended length means that CRYOLENE solutions are easy and fast to install, with reduced thermal bridging. Different facings, such as reinforced glass tissue or reinforced aluminium foil, give CRYOLENE products high tensile strength.

The properties and performance of CRYOLENE have been extensively tested by external laboratories, and the products are well-proven through decades of successful use worldwide in chemical and LNG applications.

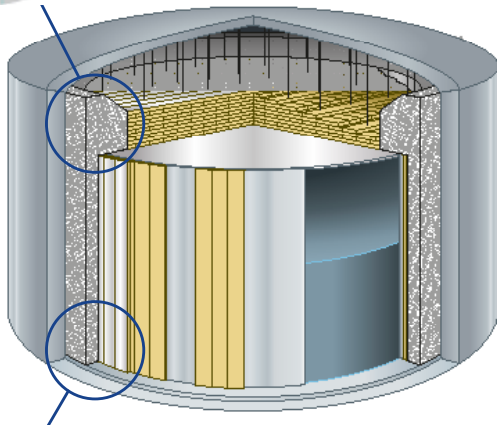
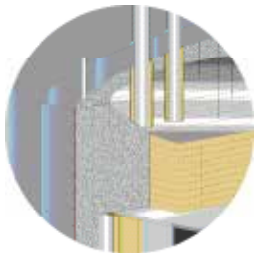

CRYOLENE	Type 681	Type 682	Type 684
Suspended decks	●	-	-
Tank shells	-	●	-
Pipe connections	-	-	●

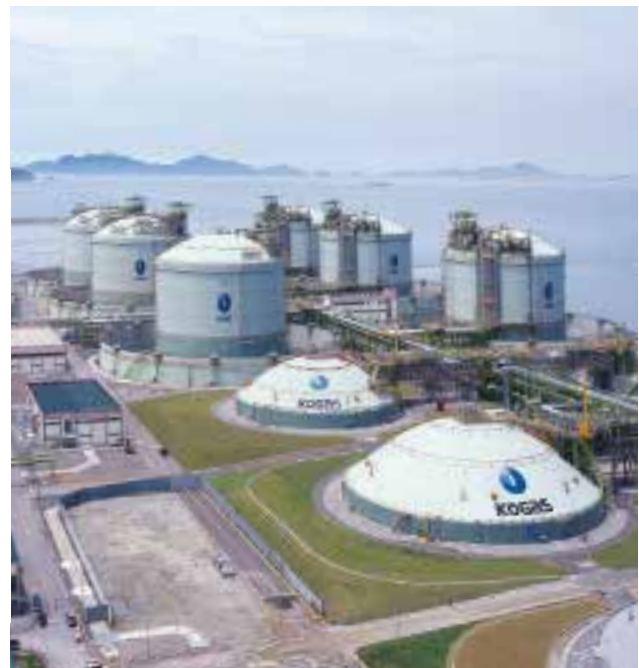

### 1.4.2 ISOVER TECH "QN" – Insulation solutions in Nuclear Quality

#### ISOVER TECH "QN" – solutions for nuclear applications

The demands on the quality of installed products is exceptionally high in nuclear power plants, especially in the nuclear island.

ISOVER has a long track record and experience in supplying special, high-quality insulation products for this sensitive area for all key players in the nuclear sector.

ISOVER products which are "QN"-marked are designed to meet these nuclear quality criteria.



#### Specialised ISOVER range for nuclear components:

- Long, resilient fibres and no shots in insulation, leading to long-term consistent thermal performance also under mechanical stress (vibrations), no loss of thickness over time and low maintenance demand
- Low or no organic content and use of stainless quality for wire mesh on mats, avoiding any risk of corrosion under insulation, smoke or emissions after first heating-up.
- Low weight combined with high energy efficiency, acoustic and fire protection performance in one product, ensures better lifetime performance and easier and therefore riskfree installation

**Products:** TECH Loose Wool QN  
TECH Telisol 5.0 QN





### 1.4.3 ISOVER "EX" - insulation solutions for Explosion Risk Areas

#### **ISOVER "EX" - solutions for air separation, liquid oxygen and explosion risk areas**

ISOVER offers a special "EX"-marked range of products that can be applied in air separation units, cold boxes and storage of liquid oxygen due to the low organic content requirements.

These products fulfill the demands of standards such as AGI 118 or so-called Linde-quality and are available as either loose wool or mechanically bonded wired mats.

**Products:** TECH Loose Wool EX,  
TECH Wired Mat MT 5.0 EX



## 2 Applications and drawings

### Introduction

**While designing a new industrial element, several options and scenarios can be encountered in terms of insulation needs, depending on the project conditions and specifications. ISOVER offers all kinds of solutions for thermal applications, keeping in mind not only the engineering point of view - space limitations, heat losses, structural weight, etc. - but also the installation perspective.**

**Showing up next, several different real-based calculation scenarios can be found, all of them selecting the unique multi-material offer that only ISOVER can bring with its three mineral wool solutions based on stone wool, glass wool and the innovative ULTIMATE, and therefore with their unique benefits.**



## 2.1 Thermal Energy Storage Salt Tanks – Wired Mats Solution



Thermal energy storage (TES) is achieved with widely differing technologies. Depending on the specific technology, it allows excess thermal energy to be stored and used hours, days, or months later. One good example is the balancing of energy demand between daytime and nighttime, as it happens in molten salt tanks for thermal energy storage in concentrating solar power (CSP) systems. With proper insulation of the tank the thermal energy can be usefully stored for up to a week.

	<b>System 1 Standard Solution</b>	<b>System 2 ISOVER Standard Solution</b>
	<b>WM-AGI-Q-132: 80-120 kg/m<sup>3</sup></b>	<b>TECH WM MT 5.1</b> 
<b>Tank volume</b>	15,877.6 m <sup>3</sup>	15,877.6 m <sup>3</sup>
<b>Thickness L1</b>	0.1 m	0.1 m
<b>Thickness L2</b>	0.1 m	0.1 m
<b>Thickness L3</b>	0.1 m	0.1 m
<b>Total thickness</b>	<b>300 mm</b>	<b>300 mm</b>
<b>Total insulation surface</b>	5,066.8 m <sup>2</sup>	5,066.8 m <sup>2</sup>
<b>Surface cladding</b>	1,697.7 m <sup>2</sup>	1,697.7 m <sup>2</sup>
<b>Insulation time savings</b>		<b>0.0 %</b>
<b>Thermal losses</b>	96.69 W/m <sup>2</sup>	88.48 W/m <sup>2</sup>
<b>Working time</b>	8,500 h/p.a.	8,500 h/p.a.
<b>Total energy loss</b>	1,395 MWh/p.a.	1,277 MWh/p.a.
<b>Heat loss savings</b>		<b>8.5 %</b>
<b>Thickness reduction</b>		<b>0.0 %</b>
<b>Surface Temperature</b>	<b>17.6 °C</b>	<b>17.0 °C</b>
<b>Insulation density</b>	100 kg/m <sup>3</sup>	100 kg/m <sup>3</sup>
<b>Total insulation volume</b>	506.7 m <sup>3</sup>	506.7 m <sup>3</sup>
<b>Total weight</b>	50.7 Tn	50.7 Tn

### Calculation hypothesis

#### Thermal Losses for Standard Insulation Thickness in salt tanks (400 mm)

Diameter = 38 m

$T_i = 385\text{ °C}$

$T_e = 10\text{ °C}$

$W_s = 4\text{ m/s}$

Height = 14 m





$F = 1$

= 0.0085 W/(mK) (spacers of steel in form of a flat bar 50 x 5 mm)

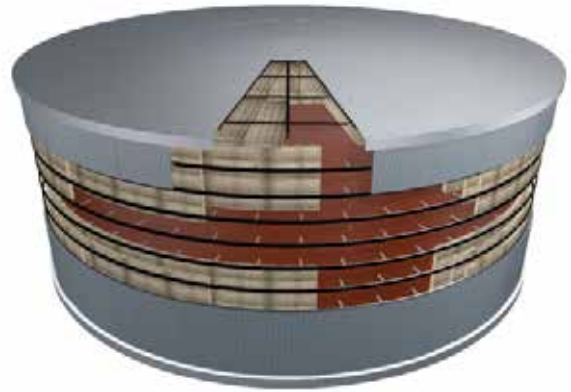
Cladding: dusty galvanized sheet metal ( $\lambda = 0.44$ )

Reference project: Ouarzazate Solar Power plant - Morocco



 <b>System 3</b> Installation Saving	 <b>System 4</b> Energy Efficiency	
<b>U TECH WM MT 4.0</b>	<b>TECH WM MT 6.1</b>	<b>U TECH WM MT 6.0</b>
		
15,877.6 m <sup>3</sup>	15,877.6 m <sup>3</sup>	15,877.6 m <sup>3</sup>
0.1 m	0.1 m	0.1 m
0.1 m	0.1 m	0.1 m
0.1 m	0.1 m	0.1 m
<b>300 mm</b>	<b>300 mm</b>	<b>300 mm</b>
5,066.8 m <sup>2</sup>	5,066.8 m <sup>2</sup>	5,066.8 m <sup>2</sup>
1,697.7 m <sup>2</sup>	1,697.7 m <sup>2</sup>	1,697.7 m <sup>2</sup>
<b>14.0 %</b>	<b>-2.8 %</b>	<b>8.4 %</b>
90.77 W/m <sup>2</sup>	84.97 W/m <sup>2</sup>	79.78 W/m <sup>2</sup>
8,500 h/p.a.	8,500 h/p.a.	8,500 h/p.a.
1,310 MWh/p.a.	1,226 MWh/p.a.	1,151 MWh/p.a.
<b>6.1 %</b>	<b>12.1 %</b>	<b>17.5 %</b>
<b>0.0 %</b>	<b>0.0 %</b>	<b>0.0 %</b>
<b>17.2 °C</b>	<b>16.7 °C</b>	<b>16.3 °C</b>
44 kg/m <sup>3</sup>	128 kg/m <sup>3</sup>	66 kg/m <sup>3</sup>
506.7 m <sup>3</sup>	506.7 m <sup>3</sup>	506.7 m <sup>3</sup>
22.3 Tn	64.9 Tn	33.4 Tn

## 2.2 Thermal Energy Storage Salt tanks - Slabs Solution



Thermal energy storage (TES) is achieved with widely differing technologies. Depending on the specific technology, it allows excess thermal energy to be stored and used hours, days, or months later. One good example is the balancing of energy demand between daytime and nighttime, as it happens in molten salt tanks for thermal energy storage in concentrating solar power (CSP) systems. With proper insulation of the tank the thermal energy can be usefully stored for up to a week.

	<b>System 1 Standard Solution</b>	<b>System 2 ISOVER Standard Solution</b>
	<b>SL-AGI-Q-132: 80-120 kg/m<sup>3</sup></b>	<b>TECH SLAB MT 5.1</b> 
<b>Tank volume</b>	15,877.6 m <sup>3</sup>	15,877.6 m <sup>3</sup>
<b>Thickness L1</b>	0.1 m	0.1 m
<b>Thickness L2</b>	0.1 m	0.1 m
<b>Thickness L3</b>	0.1 m	0.1 m
<b>Thickness L4</b>	m	m
<b>Total thickness</b>	<b>300 mm</b>	<b>300 mm</b>
<b>Total insulation surface</b>	5,066.8 m <sup>2</sup>	5,066.8 m <sup>2</sup>
<b>Surface cladding</b>	1,697.7 m <sup>2</sup>	1,697.7 m <sup>2</sup>
<b>Insulation time savings</b>		<b>0.0 %</b>
<b>Thermal losses</b>	93.50 W/m <sup>2</sup>	91.31 W/m <sup>2</sup>
<b>Working time</b>	8,500 h/p.a.	8,500 h/p.a.
<b>Total energy loss</b>	1,349 MWh/p.a.	1,318 MWh/p.a.
<b>Heat loss savings</b>		<b>2.3 %</b>
<b>Thickness reduction</b>		<b>0.0 %</b>
<b>Surface temperature</b>	<b>17.4 °C</b>	<b>17.2 °C</b>
<b>Insulation density</b>	100 kg/m <sup>3</sup>	100 kg/m <sup>3</sup>
<b>Total insulation volume</b>	506.7 m <sup>3</sup>	506.7 m <sup>3</sup>
<b>Total weight</b>	50.7 Tn	50.7 Tn

### Calculation hypothesis

#### Thermal Losses for Standard Insulation Thickness in salt tanks (400 mm)

Diameter = 38 m

$T_i = 385^\circ\text{C}$

$T_e = 10^\circ\text{C}$

$W_s = 4\text{ m/s}$

Height = 14 m

$F = 1$

= 0.0085 W/(mK) (Spacers of steel in form of a flat bar 50 x 5 mm)

Cladding: dusty galvanized sheet metal ( $\lambda = 0.44$ )

Reference project: Solar Plant Extremadura - Spain

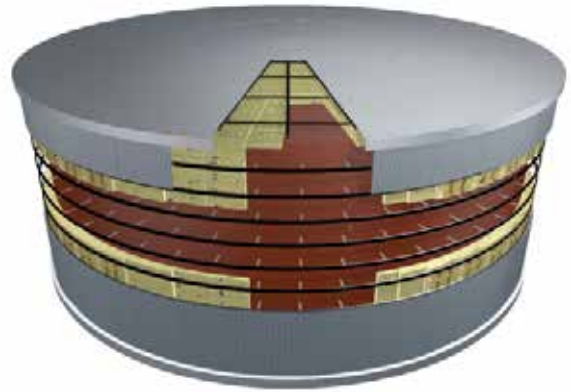

 <b>System 3</b> Installation Saving	 <b>System 4</b> Energy Efficiency	 <b>System 5</b> Space Saving
<b>U TECH SLAB MT 5.0</b>	<b>U TECH SLAB MT 6.0</b>	<b>U TECH Slab HT 8.0</b>
		
15,877.6 m <sup>3</sup>	15,877.6 m <sup>3</sup>	15,877.6 m <sup>3</sup>
0.1 m	0.1 m	0.08 m
0.1 m	0.1 m	0.08 m
0.1 m	0.1 m	0.05 m
m	m	0.05 m
<b>300 mm</b>	<b>300 mm</b>	<b>260 mm</b>
5,066.8 m <sup>2</sup>	5,066.8 m <sup>2</sup>	6,747.8 m <sup>2</sup>
1,697.7 m <sup>2</sup>	1,697.7 m <sup>2</sup>	1,694.2 m <sup>2</sup>
<b>14.0 %</b>	<b>8.4 %</b>	<b>-18.5 %</b>
84.25 W/m <sup>2</sup>	80.17 W/m <sup>2</sup>	91.24 W/m <sup>2</sup>
8,500 h/p.a.	8,500 h/p.a.	8,500 h/p.a.
1,216 MWh/p.a.	1,157 MWh/p.a.	1,314 MWh/p.a.
<b>9.9 %</b>	<b>14.3 %</b>	<b>2.4 %</b>
<b>0.0 %</b>	<b>0.0 %</b>	<b>13.3 %</b>
<b>16.7 °C</b>	<b>16.3 °C</b>	<b>17.2 °C</b>
44 kg/m <sup>3</sup>	66 kg/m <sup>3</sup>	100 kg/m <sup>3</sup>
50.7 m <sup>3</sup>	506.7 m <sup>3</sup>	438.3 m <sup>3</sup>
22.3 Tn	33.4 Tn	43.8 Tn

## 2.3 Thermal Energy Storage Sewage Tanks - Wired Mats / Rolls Solution



A sewage treatment plant produces a clean, non-polluting effluent which can be discharged directly to a stream ditch or other watercourse, or to a soak-away for dispersal into the soil. Large amounts of sewage water must be stored at a certain temperature before treatment in this kind of plant.

	<b>System 1 Standard Solution</b>	<b>System 2 ISOVER Standard Solution</b>
	<b>WM-AGI-Q-132: 50-80 kg/m<sup>3</sup></b>	<b>TECH WM MT 3.1</b> 
<b>Tank volume</b>	3,006.6 m <sup>3</sup>	3,006.6 m <sup>3</sup>
<b>Thickness L1</b>	0.09 m	0.09 m
<b>Thickness L2</b>	0.09 m	0.09 m
<b>Total thickness</b>	180 mm	180 mm
<b>Total Insulation surface</b>	1,395.7 m <sup>2</sup>	1,395.7 m <sup>2</sup>
<b>Surface cladding</b>	701.4 m <sup>2</sup>	701.4 m <sup>2</sup>
<b>Insulation time savings</b>		<b>0.0 %</b>
<b>Thermal losses</b>	9.87 W/m <sup>2</sup>	9.52 W/m <sup>2</sup>
<b>Working time</b>	8,500 h/p.a.	8,500 h/p.a.
<b>Total energy loss</b>	59 MWh/p.a.	57 MWh/p.a.
<b>Heat loss savings</b>		<b>3.5 %</b>
<b>Thickness reduction</b>		<b>0.0 %</b>
<b>Surface temperature</b>	<b>10.8 °C</b>	<b>10.7 °C</b>
<b>Insulation density</b>	70 kg/m <sup>3</sup>	70 kg/m <sup>3</sup>
<b>Total insulation volume</b>	125.6 m <sup>3</sup>	125.6 m <sup>3</sup>
<b>Total weight</b>	8.8 Tn	8.8 Tn

### Calculation hypothesis

#### Thermal Losses < 10 W/m<sup>2</sup> in storage tanks (300 mm concrete walls)

Diameter = 17 m

T<sub>i</sub> = 55 °C

T<sub>e</sub> = 10 °C

W<sub>s</sub> = 4 m/s



Height = 12.5 m

F = 1,05

= 0 W/(mK)

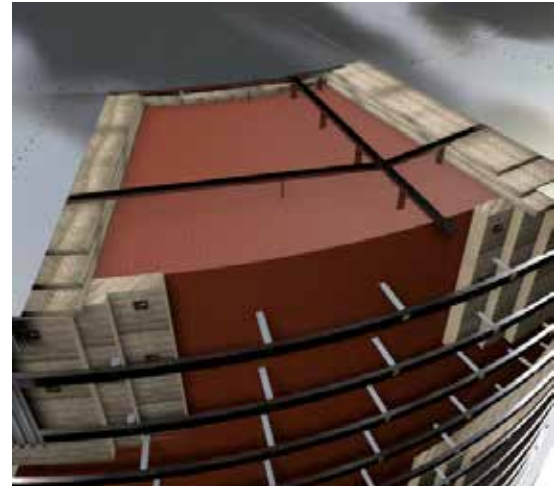
Cladding: oxidized aluminium (λ = 0.13)

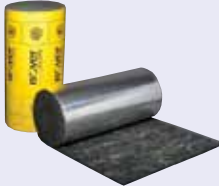

System 3 Installation Saving		System 4 Energy Efficiency		System 5 Space Saving	
<b>TECH Roll 2.0</b>		<b>TECH Crimped Roll 2.0</b>		<b>U TECH WM MT 4.0</b>	
					
3,006.6 m <sup>3</sup>	3,006.6 m <sup>3</sup>	3,006.6 m <sup>3</sup>	3,006.6 m <sup>3</sup>	3,006.6 m <sup>3</sup>	3,006.6 m <sup>3</sup>
0.09 m	0.09 m	0.09 m	0.09 m	0.08 m	0.08 m
0.09 m	0.09 m	0.09 m	0.09 m	0.08 m	0.08 m
180 mm	180 mm	180 mm	180 mm	160 mm	160 mm
1,395.7 m <sup>2</sup>	1,395.7 m <sup>2</sup>	1,395.7 m <sup>2</sup>	1,395.7 m <sup>2</sup>	1,393.3 m <sup>2</sup>	1,393.3 m <sup>2</sup>
701.4 m <sup>2</sup>	701.4 m <sup>2</sup>	701.4 m <sup>2</sup>	701.4 m <sup>2</sup>	699.8 m <sup>2</sup>	699.8 m <sup>2</sup>
<b>13.8 %</b>	<b>13.8 %</b>	<b>9.2 %</b>	<b>9.2 %</b>	<b>4.8 %</b>	<b>4.8 %</b>
9.82 W/m <sup>2</sup>	9.63 W/m <sup>2</sup>	8.60 W/m <sup>2</sup>	8.60 W/m <sup>2</sup>	9.65 W/m <sup>2</sup>	9.65 W/m <sup>2</sup>
8,500 h/p.a.	8,500 h/p.a.	8,500 h/p.a.	8,500 h/p.a.	8,500 h/p.a.	8,500 h/p.a.
59 MWh/p.a.	57 MWh/p.a.	51 MWh/p.a.	51 MWh/p.a.	57 MWh/p.a.	57 MWh/p.a.
<b>0.5 %</b>	<b>2.4 %</b>	<b>12.9 %</b>	<b>12.9 %</b>	<b>2.4 %</b>	<b>2.4 %</b>
<b>0.0 %</b>	<b>0.0 %</b>	<b>0.0 %</b>	<b>0.0 %</b>	<b>11.1 %</b>	<b>11.1 %</b>
<b>10.8 °C</b>	<b>10.7 °C</b>	<b>10.7 °C</b>	<b>10.7 °C</b>	<b>10.7 °C</b>	<b>10.7 °C</b>
22 kg/m <sup>3</sup>	34 kg/m <sup>3</sup>	44 kg/m <sup>3</sup>	44 kg/m <sup>3</sup>	55 kg/m <sup>3</sup>	55 kg/m <sup>3</sup>
125.6 m <sup>3</sup>	125.6 m <sup>3</sup>	125.6 m <sup>3</sup>	125.6 m <sup>3</sup>	111.5 m <sup>3</sup>	111.5 m <sup>3</sup>
2.8 Tn	4.3 Tn	5.5 Tn	5.5 Tn	6.1 Tn	6.1 Tn

## 2.4 Thermal Energy Storage

### Oil Buffer Storage Tanks – Slabs Solution



Fuel oils need to be heated for handling and storage purposes. Heavy fuel is normally delivered at a temperature of 50 °C or higher and should be kept and transported at this temperature. Tanks and oil pipes must be insulated to maintain the minimum handling temperatures.

	System 1 Standard Solution	System 2 ISOVER Standard Solution	
	SL-AGI-Q-132: 50-80 kg/m <sup>3</sup>	TECH Slab MT 3.1 	TECH Slab 2.0 
<b>Tank volume</b>	3,006.6 m <sup>3</sup>	3,006.6 m <sup>3</sup>	3,006.6 m <sup>3</sup>
<b>Thickness L1</b>	0.09 m	0.09 m	0.09 m
<b>Thickness L2</b>	0.09 m	0.09 m	0.09 m
<b>Total thickness</b>	180 mm	180 mm	180 mm
<b>Total insulation surface</b>	1,395.7 m <sup>2</sup>	1,395.7 m <sup>2</sup>	1,395.7 m <sup>2</sup>
<b>Surface cladding</b>	701.4 m <sup>2</sup>	701.4 m <sup>2</sup>	701.4 m <sup>2</sup>
<b>Insulation time savings</b>		<b>0.0 %</b>	<b>13,8 %</b>
<b>Thermal losses</b>	10.00 W/m <sup>2</sup>	9.73 W/m <sup>2</sup>	9.60 W/m <sup>2</sup>
<b>Working time</b>	8,500 h/p.a.	8,500 h/p.a.	8,500 h/p.a.
<b>Total energy loss</b>	60 MWh/p.a.	58 MWh/p.a.	57 MWh/p.a.
<b>Heat loss savings</b>		<b>2.7 %</b>	<b>4.0 %</b>
<b>Thickness reduction</b>		<b>0.0 %</b>	<b>0.0 %</b>
<b>Surface temperature</b>	<b>10.8 °C</b>	<b>10.8 °C</b>	<b>10.7 °C</b>
<b>Insulation density</b>	70 kg/m <sup>3</sup>	70 kg/m <sup>3</sup>	20 kg/m <sup>3</sup>
<b>Total insulation volume</b>	125.6 m <sup>3</sup>	125.6 m <sup>3</sup>	125.6 m <sup>3</sup>
<b>Total weight</b>	8.8 Tn	8.8 Tn	2.5 Tn

### Calculation hypothesis

**Thermal Losses < 15 W/m<sup>2</sup> in fuel storage tanks**

Diameter = 17 m

T<sub>i</sub> = 55°C

T<sub>e</sub> = 10°C

W<sub>s</sub> = 4 m/s

Height = 12.5 m





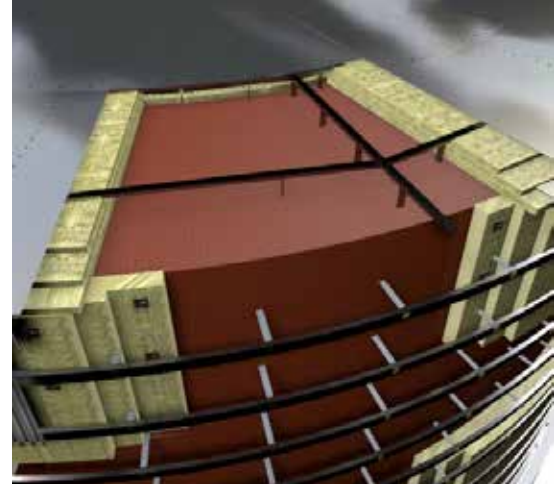

F = 1,05

= 0 W/(mK)

Cladding: oxidized aluminium (ε = 0.13)

Reference project: FHW Neukölln - Germany



System 3 Installation Saving	 System 4 Energy Efficiency	 System 5 Space savings	
<b>U TECH Slab 2.0</b>	<b>TECH Slab 3.0</b>	<b>U TECH Slab MT 5.0</b>	<b>U TECH Slab MT 5.0</b>
			
0,0 m <sup>3</sup>	3,006.6 m <sup>3</sup>	3,006.6 m <sup>3</sup>	3,006.6 m <sup>3</sup>
0.09 m	0.09 m	0.09 m	0.08 m
0.09 m	0.09 m	0.09 m	0.08 m
180 mm	180 mm	180 mm	160 mm
1,395.7 m <sup>2</sup>	1,395.7 m <sup>2</sup>	1,395.7 m <sup>2</sup>	1,393.3 m <sup>2</sup>
701.4 m <sup>2</sup>	701.4 m <sup>2</sup>	701.4 m <sup>2</sup>	699.8 m <sup>2</sup>
<b>13,8 %</b>	<b>11,5 %</b>	<b>9,2 %</b>	<b>4,8 %</b>
9.36 W/m <sup>2</sup>	8.96 W/m <sup>2</sup>	8.62 W/m <sup>2</sup>	9.65 W/m <sup>2</sup>
8,500 h/p.a.	8,500 h/p.a.	8,500 h/p.a.	8,500 h/p.a.
56 MWh/p.a.	53 MWh/p.a.	51 MWh/p.a.	57 MWh/p.a.
<b>6.4 %</b>	<b>10.4 %</b>	<b>13.8 %</b>	<b>3.7 %</b>
<b>0.0 %</b>	<b>0.0 %</b>	<b>0.0 %</b>	<b>11.1 %</b>
<b>10.7 °C</b>	<b>10.8 °C</b>	<b>10.7 °C</b>	<b>10.7 °C</b>
23 kg/m <sup>3</sup>	35 kg/m <sup>3</sup>	55 kg/m <sup>3</sup>	55 kg/m <sup>3</sup>
125.6 m <sup>3</sup>	125.6 m <sup>3</sup>	125.6 m <sup>3</sup>	111.5 m <sup>3</sup>
2.9 Tn	4.4 Tn	6.9 Tn	6.1 Tn

## 2.5 Big size Pipes

### Superheated Steam Pipe – Wired Mats / PSM Solution



Superheated steam is an extremely high-temperature vapour generated by heating the saturated steam obtained by boiling water. It is ideal for steam drying, steam oxidation and chemical processing. As industrial applications, it can be used for cleaning, steam drying, catalysis, chemical reaction processing, surface drying technologies, curing technologies, energy systems and even in nanotechnologies.

	<b>System 1 Standard Solution</b>	<b>System 2 ISOVER Standard Solution</b>
	<b>WM-AGI-Q-132: 80-120 kg/m<sup>3</sup></b>	<b>TECH WM MT 5.1</b>
		
<b>Pipe total surface</b>	2,393.9 m <sup>2</sup>	2,393.9 m <sup>2</sup>
<b>Thickness L1</b>	0.1 m	0.1 m
<b>Thickness L2</b>	0.1 m	0.1 m
<b>Thickness L3</b>	0.05 m	0.05 m
<b>F</b>	1	1
	0.01 W/(mK)	0.01 W/(mK)
<b>Total thickness</b>	<b>250 mm</b>	<b>250 mm</b>
<b>Total insulation surface</b>	10,637.4 m <sup>2</sup>	10,637.4 m <sup>2</sup>
<b>Surface cladding</b>	3,964.7 m <sup>2</sup>	3,964.7 m <sup>2</sup>
<b>Insulation time savings</b>		<b>0.0 %</b>
<b>Thermal losses</b>	302.26 W/lm	288.05 W/lm
<b>Working time</b>	8,500 h/p.a.	8,500 h/p.a.
<b>Total energy loss</b>	2,569 MWh/p.a.	2,448 MWh/p.a.
<b>Heat loss savings</b>		<b>4.7 %</b>
<b>Thickness reduction</b>		<b>0.0 %</b>
<b>Surface temperature</b>	<b>12.2 °C</b>	<b>12.1 °C</b>
<b>Insulation density</b>	100 kg/m <sup>3</sup>	100 kg/m <sup>3</sup>
<b>Total insulation volume</b>	86.5 m <sup>3</sup>	86.5 m <sup>3</sup>
<b>Total weight</b>	86.6 Tn	86.6 Tn

### Calculation hypothesis

#### Thermal Losses for Max. Insulation Thickness 250 mm. and Max. Heat Loss 305 W/lm in superheated steam pipe

Diameter = DN750

$T_i = 340\text{ °C}$

$T_e = 10\text{ °C}$

$W_s = 4.5\text{ m/s}$

Length = 1000 m

P = 10 bar

Q = 60 T/h

Cladding: oxidized aluminium ( $\lambda = 0.13$ )

Reference project: Shell Pernis Refinery - Netherlands



 <b>System 3</b> <b>Installation Saving</b>	 <b>System 4</b> <b>Energy Efficiency</b>	 <b>System 5</b> <b>Space Saving</b>
<b>U TECH WM MT 5.0</b>	<b>U TECH PSM MT 7.0</b>	<b>U TECH PSM MT 7.0</b>
		
2,393.9 m <sup>2</sup>	2,393.9 m <sup>2</sup>	2,393.9 m <sup>2</sup>
0.1 m	0.1 m	0.1 m
0.1 m	0.1 m	0.1 m
0.05 m	0.05 m	0 m
1	1	1
0.01 W/(mK)	0 W/(mK)	0 W/(mK)
<b>250 mm</b>	<b>250 mm</b>	<b>200 mm</b>
10,637.4 m <sup>2</sup>	10,637.4 m <sup>2</sup>	6,672.7 m <sup>2</sup>
3,964.7 m <sup>2</sup>	3,964.7 m <sup>2</sup>	3,650.5 m <sup>2</sup>
<b>10.2% %</b>	<b>22.2% %</b>	<b>39.5% %</b>
264.87 W/lm	253.48 W/lm	299.87 W/lm
8,500 h/p.a.	8,500 h/p.a.	8,500 h/p.a.
2,251 MWh/p.a.	2,155 MWh/p.a.	2,549 MWh/p.a.
<b>12.4 %</b>	<b>16.1 %</b>	<b>0.8 %</b>
<b>0.0 %</b>	<b>0.0 %</b>	<b>2.0 %</b>
<b>11.9 °C</b>	<b>11.9 °C</b>	<b>12.4 °C</b>
55 kg/m <sup>3</sup>	80 kg/m <sup>3</sup>	80 kg/m <sup>3</sup>
865.5 m <sup>3</sup>	865.5 m <sup>3</sup>	667.3 m <sup>3</sup>
47.6 Tn	69.2 Tn	53.4 Tn

## 2.6 Mid Size Pipes – Mid Temperature

### District heating – Pipe section and Wired Mats (two layers)



District heating is a system for distributing heat generated in a centralized location through a system of insulated pipes for residential and commercial heating requirements such as building heating and water heating. The heat is often obtained from a cogeneration plant burning fossil fuels or biomass.

	System 1 Standard Solution	System 2 ISOVER Standard Solution
	<b>PS-AGI-Q-132: 50-80 kg/m<sup>3</sup></b> <b>WM-AGI-Q-132: 70-90 kg/m</b>	<b>TECH PS MT 4.1</b> <b>TECH WM MT 4.1</b>
		
<b>Pipe total surface</b>	68.8 m <sup>2</sup>	68.8 m <sup>2</sup>
<b>Thickness L1</b>	0.04 m	0.04 m
<b>Thickness L2</b>	0.05 m	0.05 m
<b>F</b>	1.05	1.05
	0.01 W/(mK)	0.01 W/(mK)
<b>Total thickness</b>	<b>90 mm</b>	<b>90 mm</b>
<b>Total insulation surface</b>	219.3 m <sup>2</sup>	219.3 m <sup>2</sup>
<b>Surface cladding</b>	125.4 m <sup>2</sup>	125.4 m <sup>2</sup>
<b>Insulation time savings</b>		<b>0.0 %</b>
<b>Thermal losses</b>	149.51 W/lm	143.92 W/lm
<b>Working time</b>	8,500 h/p.a.	8,500 h/p.a.
<b>Total energy loss</b>	127 MWh/p.a.	122 MWh/p.a.
<b>Heat loss savings</b>		<b>3.7 %</b>
<b>Thickness reduction</b>		<b>0.0 %</b>
<b>Surface temperature</b>	<b>49.8 °C</b>	<b>48.87 °C</b>
<b>Insulation density</b>	75 kg/m <sup>3</sup>	75 kg/m <sup>3</sup>
<b>Total insulation volume</b>	10.0 m <sup>3</sup>	10.0 m <sup>3</sup>
<b>Total weight</b>	0.8 Tn	0.8 Tn

## Calculation hypothesis

### Thermal Losses for Max. Surface Temp. 50 °C on steam and condensate pipes

Diameter = 8"  
 $T_i = 250^{\circ}\text{C}$   
 $T_e = 20^{\circ}\text{C}$   
 Indoor  
 Length = 100 m  
 Cladding: bright aluminium ( $\epsilon = 0.05$ )  
 Reference project: Ecluse project - Netherlands

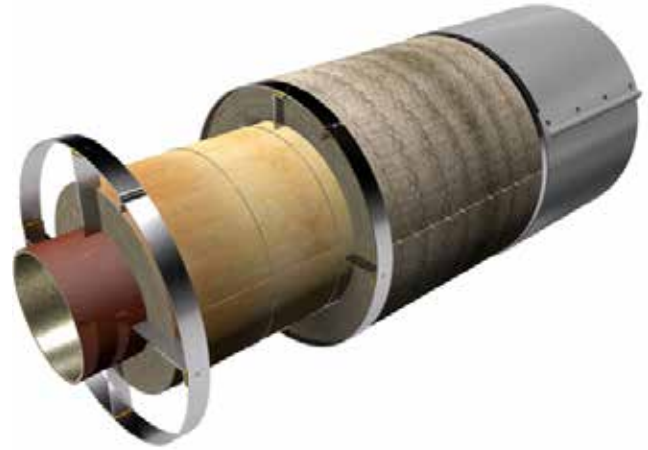



 <b>System 3</b> Installation Saving	 <b>System 4</b> Energy Efficiency	 <b>System 5</b> Space Saving
<b>U TECH PS MT 4.0</b> <b>U TECH WM MT 4.0</b>	<b>U TECH PS MT 4.0</b> <b>U TECH WM MT 5.0</b>	<b>U TECH PS MT 4.0</b> <b>U TECH WM MT 6.0</b>
		
68.8 m <sup>2</sup>	68.8 m <sup>2</sup>	68.8 m <sup>2</sup>
0.04 m	0.04 m	0.04 m
0.05 m	0.05 m	0.04 m
1.05	1.05	1.05
0.01 W/(mK)	0.01 W/(mK)	0.01 W/(mK)
<b>90 mm</b>	<b>90 mm</b>	<b>80 mm</b>
219.3 m <sup>2</sup>	219.3 m <sup>2</sup>	213.1 m <sup>2</sup>
125.4 m <sup>2</sup>	125.4 m <sup>2</sup>	119.1 m <sup>2</sup>
<b>7.9% %</b>	<b>5.9% %</b>	<b>2.0% %</b>
137.77 W/lm	121.13 W/lm	145.87 W/lm
8,500 h/p.a.	8,500 h/p.a.	8,500 h/p.a.
117 MWh/p.a.	103 MWh/p.a.	124 MWh/p.a.
<b>7.9 %</b>	<b>19.0 %</b>	<b>2.4 %</b>
<b>0.0 %</b>	<b>0.0 %</b>	<b>11.1 %</b>
<b>47.9 °C</b>	<b>45.1 °C</b>	<b>50.0 °C</b>
55 kg/m <sup>3</sup>	65 kg/m <sup>3</sup>	75 kg/m <sup>3</sup>
10.0 m <sup>3</sup>	10.0 m <sup>3</sup>	8.5 m <sup>3</sup>
0.6 Tn	0.7 Tn	0.6 Tn

## 2.7 Mid Size Pipes – High Temperature

### Steam Reformer Pipe – Pipe section and Wired Mats (two layers)



Most hydrogen produced today is made via steam-methane reforming, a mature production process in which high-temperature steam is used to produce hydrogen from a methane source, such as natural gas.

	System 1 Standard Solution	System 2 ISOVER Standard Solution	 System 3 Installation Saving
	<b>PS-AGI-Q-132:</b> 50–80 kg/m <sup>3</sup>  <b>WM-AGI-Q-132:</b> 70–90 kg/m <sup>3</sup>	<b>TECH PS MT 4.1</b> <b>TECH WM MT 4.1</b>  	<b>U TECH PS MT 4.0</b> <b>U TECH WM MT 4.0</b>  
<b>Pipe total surface</b>	68.8 m	68.8 m	68.8 m
<b>Thickness L1</b>	0.1 m	0.1 m	0.1 m
<b>Thickness L2</b>	0.1 m	0.1 m	0.1 m
<b>Thickness L3</b>	0.05 m	0.05 m	0.05 m
<b>F</b>	1.05	1.05	1.05
	0.01 W/(mK)	0.01 W/(mK)	0.01 W/(mK)
<b>Total thickness</b>	250 mm	250 mm	250 mm
<b>Total insulation surface</b>	552.1 m	552.1 m	552.1 m
<b>Surface cladding</b>	225.9 m	225.9 m	225.9 m
<b>Insulation time savings</b>		<b>0.0 %</b>	<b>7.9 %</b>
<b>Thermal losses</b>	271.06 W/lm	226.84 W/lm	241.01 W/lm
<b>Working time</b>	8,500 h/p.a.	8,500 h/p.a.	8,500 h/p.a.
<b>Total energy loss</b>	230 MWh/p.a.	193 MWh/p.a.	205 MWh/p.a.
<b>Heat loss savings</b>		<b>16.3 %</b>	<b>11.1 %</b>
<b>Thickness reduction</b>		<b>0.0 %</b>	<b>0.0 %</b>
<b>Surface temperature</b>	<b>49.5 °C</b>	<b>46.2 °C</b>	<b>47.4 °C</b>
<b>Insulation density</b>	75 kg/m	75 kg/m	55 kg/m
<b>Total insulation volume</b>	43.9 m	43.9 m	43.9 m
<b>Total weight</b>	3.3 Tn	3.3 Tn	2.4 Tn

### Calculation hypothesis

**Thermal Losses for Max. Surface Temp. 50 °C on an indoor process pipe line**

Diameter = 8"  
 Length = 100 m  
 $T_i = 500\text{ °C}$   
 $T_e = 20\text{ °C}$   
 Indoor  
 Cladding: bright aluminium ( $\epsilon = 0.05$ )

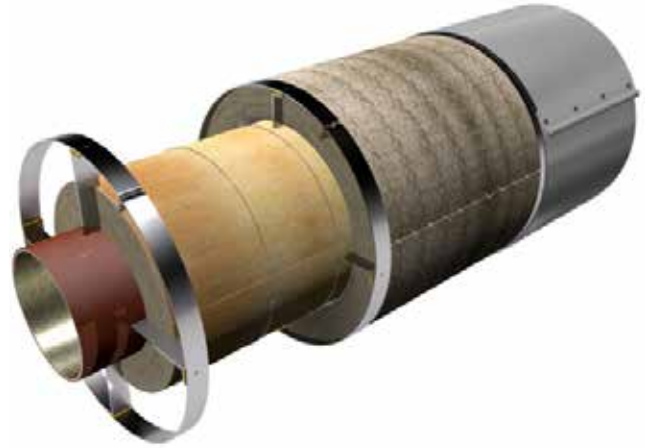

**System 4 Energy Efficiency**

TECH PS MT 4.1 TECH WM MT 5.1		U TECH PS MT 4.0 U TECH WM MT 5.0	
68.8 m	68.8 m	68.8 m	68.8 m
0.1 m	0.1 m	0.1 m	0.1 m
0.1 m	0.1 m	0.07 m	0.07 m
0.05 m	0.05 m	0.06 m	0.06 m
1.05	1.05	1.05	1.05
0.01 W/(mK)	0.01 W/(mK)	0.01 W/(mK)	0.01 W/(mK)
250 mm	250 mm	230 mm	230 mm
552.1 m	552.1 m	520.7 m	520.7 m
225.9 m	225.9 m	213.3 m	213.3 m
<b>-2.0 %</b>	<b>5.9 %</b>	<b>-3.9 %</b>	<b>2.0 %</b>
221.29 W/lm	211.75 W/lm	227.83 W/lm	240.42 W/lm
8,500 h/p.a.	8,500 h/p.a.	8,500 h/p.a.	8,500 h/p.a.
188 MWh/p.a.	180 MWh/p.a.	194 MWh/p.a.	204 MWh/p.a.
<b>18.4 %</b>	<b>21.9 %</b>	<b>1.9 %</b>	<b>11.3 %</b>
<b>0.0 %</b>	<b>0.0 %</b>	<b>8.0 %</b>	<b>8.0 %</b>
<b>45.7 °C</b>	<b>44.8 °C</b>	<b>50.0 °C</b>	<b>48.6 °C</b>
100 kg/m	65 kg/m	115 kg/m	75 kg/m
43.9 m	43.9 m	38.3 m	38.3 m
4.4 Tn	2.9 Tn	4.4 Tn	2.9 Tn

**System 5 Space Saving**

TECH PS MT 4.1 TECH WM MT6.1		U TECH PS MT 4.0 U TECH WM MT 6.0	
68.8 m	68.8 m	68.8 m	68.8 m
0.1 m	0.1 m	0.1 m	0.1 m
0.07 m	0.07 m	0.07 m	0.07 m
0.06 m	0.06 m	0.06 m	0.06 m
1.05	1.05	1.05	1.05
0.01 W/(mK)	0.01 W/(mK)	0.01 W/(mK)	0.01 W/(mK)
230 mm	230 mm	230 mm	230 mm
520.7 m	520.7 m	520.7 m	520.7 m
213.3 m	213.3 m	213.3 m	213.3 m
<b>-3.9 %</b>	<b>2.0 %</b>	<b>-3.9 %</b>	<b>2.0 %</b>
227.83 W/lm	211.75 W/lm	227.83 W/lm	240.42 W/lm
8,500 h/p.a.	8,500 h/p.a.	8,500 h/p.a.	8,500 h/p.a.
194 MWh/p.a.	180 MWh/p.a.	194 MWh/p.a.	204 MWh/p.a.
<b>1.9 %</b>	<b>21.9 %</b>	<b>1.9 %</b>	<b>11.3 %</b>
<b>8.0 %</b>	<b>0.0 %</b>	<b>8.0 %</b>	<b>8.0 %</b>
<b>50.0 °C</b>	<b>44.8 °C</b>	<b>50.0 °C</b>	<b>48.6 °C</b>
115 kg/m	65 kg/m	115 kg/m	75 kg/m
38.3 m	43.9 m	38.3 m	38.3 m
4.4 Tn	2.9 Tn	4.4 Tn	2.9 Tn

## 2.8 Small Size Pipes - Low Temperature

### Hot Water Pipe - Pipe section



A heat pipe consists of a sealed pipe or tube made of a material that is compatible with the working fluid such as copper for water heat pipes. Although the temperature inside these kinds of pipes is not very high, if the length is long, a large amount of heat can be lost along its way if they are not correctly insulated.

	System 1 Standard Solution	System 2 ISOVER Standard Solution
	<b>PS-AGI-Q-132: 50-80 kg/m<sup>3</sup></b>	<b>TECH PS MT 4.0</b>
		
<b>Pipe total surface</b>	28.7 m <sup>2</sup>	28.7 m <sup>2</sup>
<b>Thickness L1</b>	0.09 m	0.09 m
<b>F</b>	1	1
	0 W/(mK)	0 W/(mK)
<b>Total thickness</b>	<b>90 mm</b>	<b>90 mm</b>
<b>Total insulation surface</b>	74.0 m <sup>2</sup>	74.0 m <sup>2</sup>
<b>Surface cladding</b>	74.0 m	74.0 m
<b>Thermal losses</b>	19.46 W/lm	18.58 W/lm
<b>Working time</b>	8,500 h/p.a.	8,500 h/p.a.
<b>Total energy loss</b>	13.2 MWh/p.a.	12.6 MWh/p.a.
<b>Heat loss savings</b>		<b>4.5 %</b>
<b>Thickness reduction</b>		<b>0.0 %</b>
<b>Surface temperature</b>	<b>24.6 °C</b>	<b>24.4 °C</b>
<b>Insulation density</b>	75 kg/m <sup>3</sup>	65 kg/m <sup>3</sup>
<b>Total insulation volume</b>	6.7 m <sup>3</sup>	6.7 m <sup>3</sup>
<b>Total weight</b>	0.5 Tn	0.4 Tn

## Calculation hypothesis

### Thermal Losses < 20 W/lm water pipe

Diameter = 4"  
 $T_i = 70\text{ }^\circ\text{C}$   
 $T_e = 20\text{ }^\circ\text{C}$   
 Indoor  
 Length = 80 m  
 Indoor hangers ( $Z_x$ ): 0.15  
 Cladding: bright aluminium ( $\epsilon = 0.05$ )  
 Reference project: Hotel Accor, France  
 (not in the database)

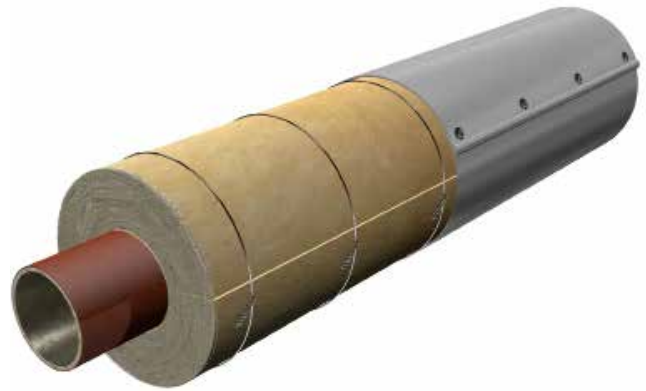

 <b>System 3</b> Energy Efficiency	 <b>System 4</b> Space Saving
<b>U TECH PS MT 4.0</b>	<b>U TECH PS MT 4.0</b>
	
28.7 m <sup>2</sup>	28.7 m <sup>2</sup>
0.12 m	0.08 m
1	1
0 W/(mK)	0 W/(mK)
<b>120 mm</b>	<b>80 mm</b>
89.0 m <sup>2</sup>	68.9 m <sup>2</sup>
89.0 m	68.9 m
17.02 W/lm	19.44 W/lm
8,500 h/p.a.	8,500 h/p.a.
11.6 MWh/p.a.	13.2 MWh/p.a.
<b>12.5 %</b>	<b>0.1 %</b>
<b>-33.3 %</b>	<b>11.1 %</b>
<b>24.4 °C</b>	<b>24.8 °C</b>
65 kg/m <sup>3</sup>	65 kg/m <sup>3</sup>
10.7 m <sup>3</sup>	5.5 m <sup>3</sup>
0.7 Tn	0.4 Tn

## 2.9 Valve insulation – Mid Temperature Oil process – Mattresses



An insulation mattress is a removable tailor-made insulation for elements that need periodical maintenance checks. It has a thermo-resistant textile covering the insulation material stuffed in it.



	System 1 Uninsulated	System 2 Standard Solution
		<b>Box</b> <b>WM-AGI-Q-132: 70-90 kg/m<sup>3</sup></b>
<b>Thickness L1</b>		0.09 m
<b>F</b>		1,1
<b>Total thickness</b>	<b>0 mm</b>	<b>90 mm</b>
<b>Insulation time savings</b>		<b>0.0 %</b>
<b>Thermal losses</b>	3278.17 W	160.49 W
<b>Working time</b>	8,500 h/p.a.	8,500 h/p.a.
<b>Total energy loss</b>	27.9 MWh/p.a.	1.4 MWh/p.a.
<b>Heat loss savings</b>		<b>95.1 %</b>
<b>Surface temperature</b>	<b>249.8 °C</b>	<b>46.6 °C</b>

## Calculation hypothesis

### Thermal Losses Valve process oil pipe

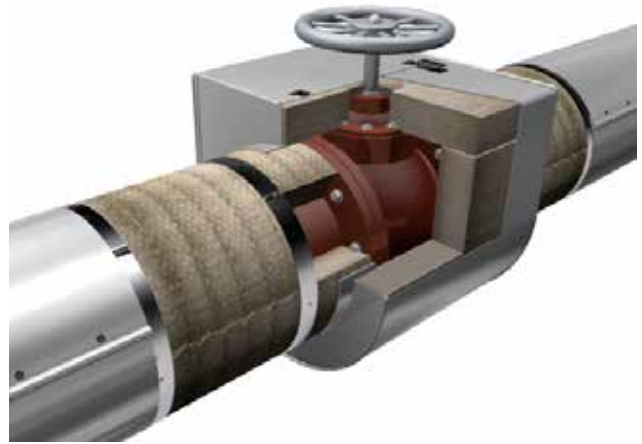
Diameter = 8"  
 $T_i = 250\text{ °C}$   
 $T_e = 15\text{ °C}$   
 Indoor  
 Eq. length = 1 m  
 Cladding box: bright aluminium ( $\epsilon = 0.05$ )  
 Cladding mattress: textile ( $\epsilon = 0.94$ )  
 Reference project: Ecluse project, Netherlands



System 3 ISOVER Standard Solution	System 4 Installation Saving	System 5 Energy Efficiency
<b>Box</b> TECH WM MT 4.1	<b>Mattress</b> U TECH Roll MT 4.0	<b>Box</b> U TECH WM MT 6.0
		
0.09 m	0.09 m	0.09 m
1.1	1.1	1.1
0.01 W/(mK)	0.08 W/(mK)	0.01 W/(mK)
<b>90 mm</b>	<b>90 mm</b>	<b>90 mm</b>
<b>0.0 %</b>	<b>90.0 %</b>	<b>0.0 %</b>
153.91 W	300.15 W	133.24 W
8,500 h/p.a.	8,500 h/p.a.	8,500 h/p.a.
1.3 MWh/p.a.	2.6 MWh/p.a.	1.1 MWh/p.a.
<b>95.3 %</b>	<b>90.8 %</b>	<b>95.9 %</b>
<b>45.6 °C</b>	<b>40.2 °C</b>	<b>4.,2 °C</b>

## 2.10 Flange insulation – Mid Temperature Oil process – Mattresses



An insulation mattress is a removable tailor made insulation for elements that needs periodical maintenance checks. It has a thermo-resistant textile covering the insulation material stuffed in it.



	System 1 Uninsulated	System 2 Standard Solution
		<b>Box WM-AGI-Q-132: 70-90 kg/m<sup>3</sup></b>
<b>Thickness L1</b>		0.09 m
<b>F</b>		1.1
		0.01 W/(mK)
<b>Total thickness</b>	<b>0 mm</b>	<b>90 mm</b>
<b>Insulation time savings</b>		<b>0.0 %</b>
<b>Thermal losses</b>	1639.09 W	80.245 W
<b>Working time</b>	8,500 h/p.a.	8,500 h/p.a.
<b>Total energy loss</b>	13.9 MWh/p.a.	0.7 MWh/p.a.
<b>Heat loss savings</b>		<b>95.1 %</b>
<b>Surface temperature</b>	<b>249.8 °C</b>	<b>46.6 °C</b>

## Calculation hypothesis

### Thermal Losses Flange process oil pipe

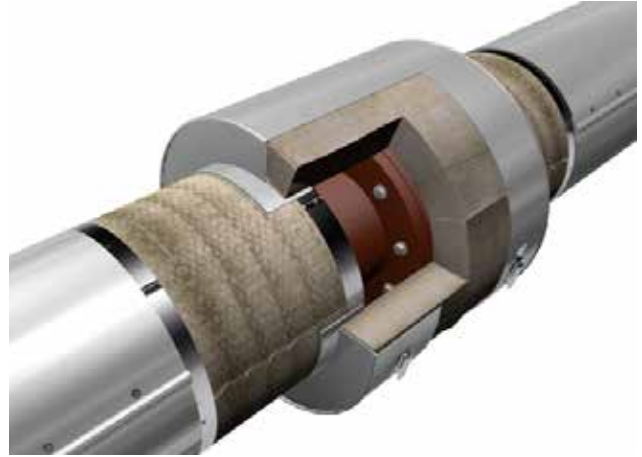
Diameter = 8"  
 Ti = 250 °C  
 Te = 15 °C  
 Indoor  
 Eq. length = 1 m  
 Cladding box: bright aluminium ( $\lambda = 0.05$ )  
 Cladding mattress: textile ( $\lambda = 0.94$ )  
 Reference project: Ecluse project, Netherlands



System 3 ISOVER Standard Solution	System 4 Installation Saving	System 5 Energy Efficiency
<b>Box</b> TECH WM MT 4.1	<b>Mattress</b> U TECH Roll MT 4.0	<b>Box</b> U TECH WM MT 6.0
		
0.09 m	0.09 m	0.09 m
1.1	1.1	1.1
0.01 W/(mK)	0.08 W/(mK)	0.01 W/(mK)
<b>90 mm</b>	<b>90 mm</b>	<b>90 mm</b>
<b>0.0 %</b>	<b>90.0 %</b>	<b>0.0 %</b>
76.96 W	150.08 W	66.62 W
8,500 h/p.a.	8,500 h/p.a.	8,500 h/p.a.
0.7 MWh/p.a.	1.3 MWh/p.a.	0.6 MWh/p.a.
<b>95.3 %</b>	<b>90.8 %</b>	<b>95.9 %</b>
<b>45.6 °C</b>	<b>40.2 °C</b>	<b>42.2 °C</b>

## 3 Installation Guidelines

### 3.1 Introduction

Thermal Insulation is required for safety and security, to reduce heat loss and to increase the sustainability of industrial processes.

Thermal insulation is intended to reduce major thermal losses through the surface of equipment, tanks, pipes..., which, because of the mechanical requirements and/or the high operating temperatures, are constructed from metallic materials with high thermal conductivity. Optimizing the initial insulation will reduce installation costs and will provide maximum energy savings throughout the lifetime of the installation. The reduction in heat losses achieved by the insulation means a significant saving when it comes to energy costs, but it also enables a proper functioning of the different industrial processes. Insulation contributes to maintaining temperature limits in processes for transported or stored liquid or gaseous media, to preventing corrosion due to high humidity levels or temperatures below the dew point, as well as to preventing pipework and equipment from freezing in low ambient temperatures.

Another important aspect where insulation has an important role is the control of the temperature of the outer surface, protecting personnel from contact injuries and skin burns when working close to hot pipe and equipment surfaces.

Last but not least, insulation is key in reducing environmental impact. Optimising the insulation efficiency will maximise the potential for CO<sub>2</sub>-saving, providing a buffer against future rising energy costs. ISOVER offers a wide range of products in different forms depending on the application, operating temperature specific requirements or adaptability to the insulation surface: pipe sections, wired mats, lamella mats, rolls, crimped rolls, slabs, loose wool....

It is important to note that the following is a general description of the most common insulation systems used in industry with the sole intention of providing some practical guidelines and recommendations based on our experience and mainly focused on the installation of the insulating materials. The Thermal Insulation Standards and more specifically the Thermal Insulation Specification approved for each project is the one that should prevail, as it is the one describing in detail the insulation procedures and requirements to better fit the particularities of the project.

Any detailed description of the metallic jacketing and associated support systems, flexible finishing materials, as well as auxiliary materials are intentionally excluded from the scope of these guidelines except when necessary.

### 3.2 Occupational health, safety and risk prevention

Before installation of thermal insulation starts, all contractors must comply with the requirements expressed by the customer in terms of EHS (environment, health and safety). Therefore, the contractor should meet all of the requirements relating to the health and safety of the workers included in the contract, and those of current legislation in each country, for the whole insulation system, including the materials, surface preparation, installation of the insulation, waste management, etc. All of the products supplied will have a Safety Data Sheet. Before the work or any activity starts, the contractor will hand over to its client, for approval, the health and safety plan or a prevention plan that contains at least the following:

- Organisation of on-site prevention, organisational structure and responsibilities.
- Risk assessment for the health and safety of the workers for all of the activities to be completed, taking into account the environmental conditions and the information contained in the safety data sheets of each of the materials to be used.
- Protective and preventive measures and activities applicable to the risks indicated.
- Emergency plan envisaged for first aid, fire-fighting and the evacuation of workers.
- Periodic inspection programme for working conditions and the activities to detect and correct potentially dangerous situations.

With regard to the environment, the contractor should meet the requirements of the client's environmental policy, such as:

- Environmental specifications for suppliers and contractors.
- Industrial waste management procedures.
- Instructions for the collection, handling, packaging, storage and internal management of waste.
- Environmental policy of the client.

### 3.3 Preliminary and general observations

All insulation and finishing materials shall be new, free of damage, conform to the requirements and protected from moisture during transport, storage and installation. In wet weather conditions, installed insulation should be protected temporarily until the final application of the permanent jacketing by means of temporary polyethylene sheeting. Irrespective of whether a temporary enclosure is being employed, the insulation should be protected against ingress of water at all times.

Insulation works will not begin until all necessary coatings and system pressure, welding and leak tests for the pipe or equipment has been completed.

An authorization document for each element to be insulated should be issued by the client prior to start the insulation works

Corrosion under insulation continues to be a major issue, and in order to minimise the effects of CUI, it is imperative that sufficient, detailed consideration is given, firstly, to surface preparation, secondly, to proper installation minimising the risk of water ingress and thirdly, to routine inspection, visual or otherwise, of insulation once installed.

Since Corrosion Under Insulation is basically the corrosion of the metal lying under the insulation, the first solution to prevent it is to protect this metal from liquid water and/or oxygen. This is done usually with corrosion protective paintings or coatings. Therefore, before the application of any insulation, it is recommended that all carbon, low alloy and stainless steel piping and equipment be protected against corrosion, in the event that the insulation becomes wet, by appropriate coating application, paying special attention to the pipe inlet/outlet areas, connections, flanges, manholes, supports, lifting lugs or areas where a break in the insulation is anticipated and therefore where there is a possibility of water or moisture being present.

The next step will be to verify that the surface is, insofar as is possible, fully dry and free from oil, grease, scales and loose particles originated from other assembly processes (burrs, weld spatter, dust, etc.) prior to insulation being applied.

Even if the protective coating of the metal is not part of the insulation contractor's job, it is strongly advisable to check if it has been applied properly and inform the process owner if risks are detected.

Additionally, to prevent corrosion under insulation from occurring, as well as keep a good thermal performance, the insulation system should always be designed and installed in order to minimise the risk of water ingress and liquid water accumulation, keeping the whole system as dry as possible. As in the long term the absence of water ingress cannot be fully guaranteed and considering the hygroscopic properties of mineral wools, prevention of water accumulation solutions (like drainage plugs and holes) but also maintenance and control should be planned.

Insulation and cladding should be properly supported and secured, and specific attention should be given to relevant methods at the process equipment design stage. Individual pieces of insulating material should fit closely together and to the surfaces being insulated. Metal cladding should normally be secured using metal banding, self tapping screws and/or blind pop rivets.

Metal sheets for cladding should be as large as practicable to minimise the number of joints. Cladding should be fabricated from the selected type of flat or profiled sheet metal cut and assembled to contour, always being applied so as to shed water, and where weatherproofing is required, all these joints should be sealed and have sufficient overlap. Gaps or cavities should be avoided as far as possible.

The type of supporting systems for the cladding when necessary, will be determined by the size, geometry and specific requirements of the component to insulate. In all cases it is highly recommended the installation of pieces of ceramic board or glass fabric in the joints between the spacer pins and support rings to minimize thermal bridges.

When installing the insulation and associated supports or spacers if any, damages to the protective coating must be avoided.

### 3.4 Insulation systems for pipes

Depending on the size, geometry and type of material of the pipe, the type of insulation, the type of cladding and also the particular specifications for thermal insulation, there are several specific details to take into account in the installation process

ISOVER offers a wide range of Glass Wool, Stone Wool and ULTIMATE solutions specially designed for industrial pipes in the form of pipe sections or mats: TECH Pipe Sections, TECH Wired Mats, U TECH Pipe Sections, U TECH Wired Mats and U TECH Pipe Section Mats.

The best choice will depend on each particular case and will be subjected to several factors including the working temperature, size of the pipe or ease of assembly among others.

Further on, some practical recommendations for installing mineral wool on pipes are described.

#### 3.4.1 Straight sections. One layer of insulation

##### 3.4.1.1 Pipe Section Solution

ISOVER TECH Pipe Sections are preformed concentric-rolled elements, pre-slit to facilitate the opening and fitting over the pipes. They can be used without support structures and have a beneficial length of 1.2 m what makes the installation fast and efficient reducing also significantly the thermal bridges.

The first step is slightly open the longitudinal cut of the pipe section to fit it on the pipe. For horizontal pipes the longitudinal cuts should be located at the bottom. For vertical pipes they should be staggered between pieces around 30 degrees.

Later the pipe section must be secured in place by placing steel wire lacings (0.5 mm diameter) around the perimeter of the pipe and tightly intertwining and embedding the ends in the insulation itself. The maximum recommended spacing between wire lacings will be 300 mm, leaving at least 3 lacings per linear meter

Figure 1. PIPING – Straight Pipe (Pipe Section), small diameter

1. Pipe
2. Pipe section
3. Binding wire
4. Cladding
5. Screws, selftappers or blind rivets

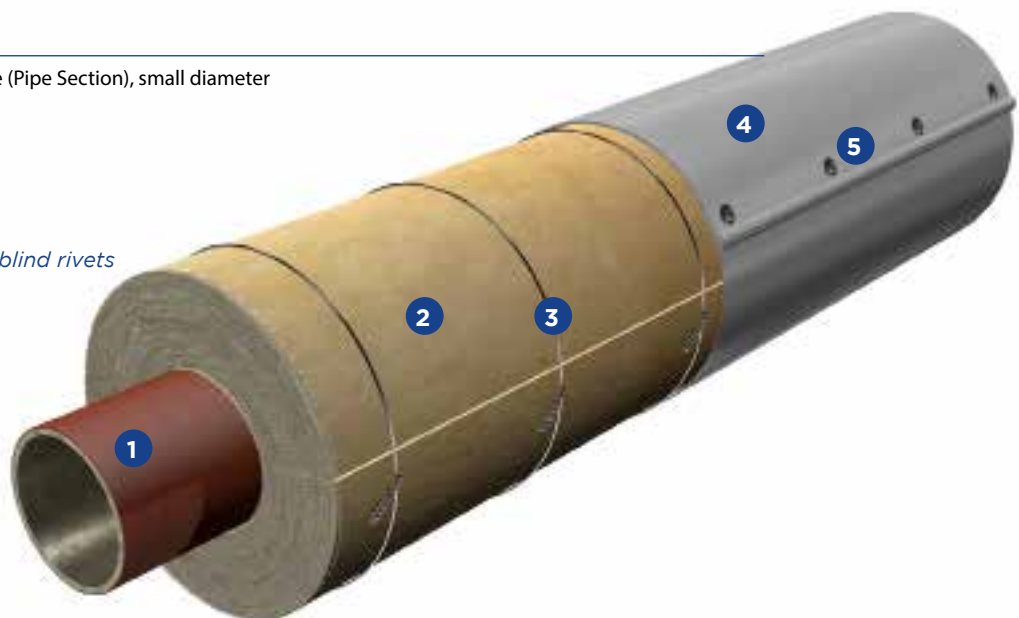

### 3.4.1.2 Wired Mat Solution

Prior to the insulation, spacer rings will be placed when necessary as supporting structure for the insulation and mechanical protection and to keep a uniform distance between the cladding and the pipe surface.

When applying brackets or welded supports the insulation system shall be applied after installation and shall be adapted to the type of support.

The standard method used for flexible insulation of medium and big diameter process pipes is usually the installation of wired mats. ISOVER's mineral wool mat solutions, TECH Wired Mat and U TECH Wired Mat, are stitched with galvanized wire on hexagonal galvanized wire mesh for flexible and ease installation especially on big diameter pipes. On request they are also available with reinforced aluminium facing as well as with stainless steel wire and wire mesh (recommended for pipes operating at  $> 400\text{ }^{\circ}\text{C}$ ).

The wired mats shall be previously cut to a size equal to the "outer diameter of the pipe + 2 x insulation thickness" and subsequently placed on the pipe.

For a tight insulation system, individual sections will be butt-jointed, the joints shall be applied staggered and shall be tacked with a 0,5-1 mm diameter stainless steel wire or stainless steel blanket hooks at a pitch of 50 mm. In the case of galvanized wire blankets, galvanized blanket hooks shall be used.

For fastening of wired mats stainless steel bands shall be used with minimum dimensions 12 mm x 0.5 mm and at intervals of  $\leq 300\text{ mm}$

Figure 2. PIPING – Straight Pipe (Wired Mat)

1. Thick gasket or glass fabric
2. Spacer
3. Supporting ring
4. Pipe
5. Tacking thread
6. Wired mat
7. Cladding
8. Screws, selftappers or blind rivets

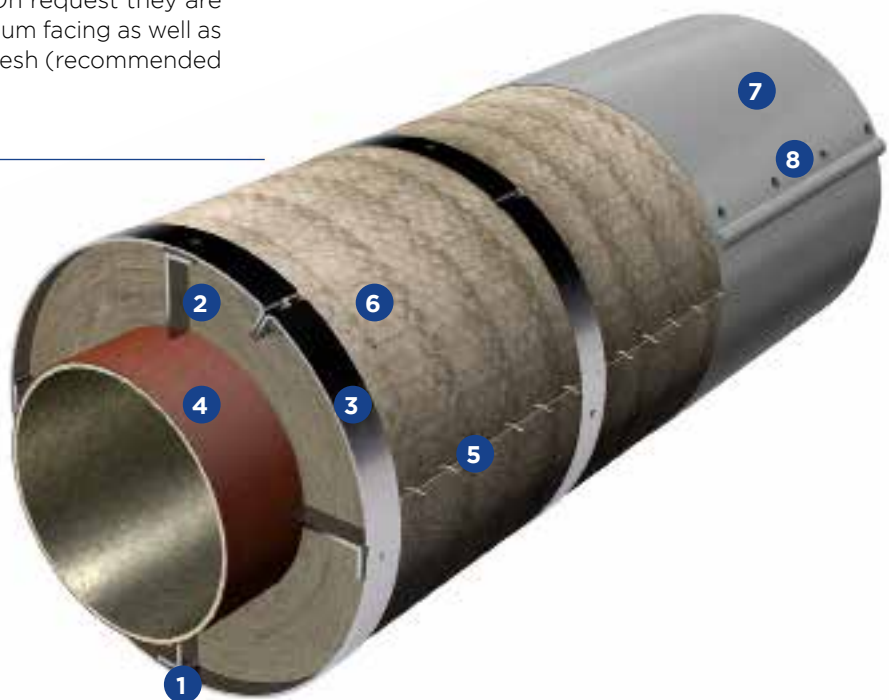

### 3.4.1.3 Pipe Section Mat Solution

As the standard method used for flexible insulation of big diameter process pipes ISOVER offers two flexible pipe insulation alternatives that do not require installation with support structures due to their exceptional compressive strength.

- Compression-resistant Lamella Mats in glass and stone wool can be used irrespective of the pipe diameter.
- ULTIMATE Pipe Section Mats (PSM), the extra-efficient and fast solution to insulate large-diameter pipelines. The length and the V-shaped cuts of the PSM are factory adapted to the final diameter and thickness

of the pipe insulation, leaving no thermal bridges once installed. This is a major benefit as the product is delivered flat-packed to save transport costs and space, and ready to install, not being necessary any kind of cutting process on site. The glass woven fabric facing improves the mechanical resistance during and after installation. Pre-cutted parts to form elbows and connections are also available on request.

The mat is easily placed around the pipe, adapting quickly to it. Pipe Section Mats are normally secured using steel wire lacings around the perimeter of the pipe. This solution is highly recommended for large diameters for its lightness, compressive strength and ease of installation.



Figure 3. PIPING – Straight Pipe (PSM)

1. Pipe
2. Pipe section mat
3. Binding wire
4. Cladding
5. Screws, selftappers or blind rivets

### 3.4.2 Straight sections. Two or more layers of insulation

Prior to the insulation, spacer rings will be placed when necessary as supporting structure for the insulation and mechanical protection and to keep a uniform distance between the cladding and the pipe surface.

When applying brackets or welded supports the insulation system shall be applied after installation and shall be adapted to the type of support.

When the required thickness of the insulation is greater than 100mm or when the operating temperatures are above 300°C, it is normally recommended to use several layers of insulation which number will depend on the final thickness required. The total insulation thickness will be obtained by three possible combinations:

- several layers of **Pipe Sections**, TECH Pipe Section/U TECH Pipe Section/U TECH Pipe Section Mat
- several layers of **Wired Mats**, TECH Wired Mat/U TECH Wired Mat
- several layers of **Pipe Sections** and **Wired Mats**

The insulation shall be placed in two or more layers making sure that the longitudinal and horizontal joints are staggered between layers to avoid thermal bridges

Assembly and fastening of any of the proposed solutions, should be done in the same way as in the previous section, on the basis of the characteristics of each format (pipe section, pipe section mat and wired mat).

For pipes with a diameter greater than 250 mm, fastening of the outer layer of insulation should be reinforced by way of galvanised or stainless steel bands with minimum dimensions 12 mm x 0.5 mm and at intervals of  $\leq 300$  mm.

Figure 4. PIPING – Straight Pipe  
(Pipe Section + Wired Mat)

1. Thick gasket or glass fabric
2. Spacer
3. Supporting ring
4. Pipe
5. Tacking thread
6. Wired mat
7. Cladding
8. Screws, selftappers or blind rivets
9. Pipe section
10. Binding wire

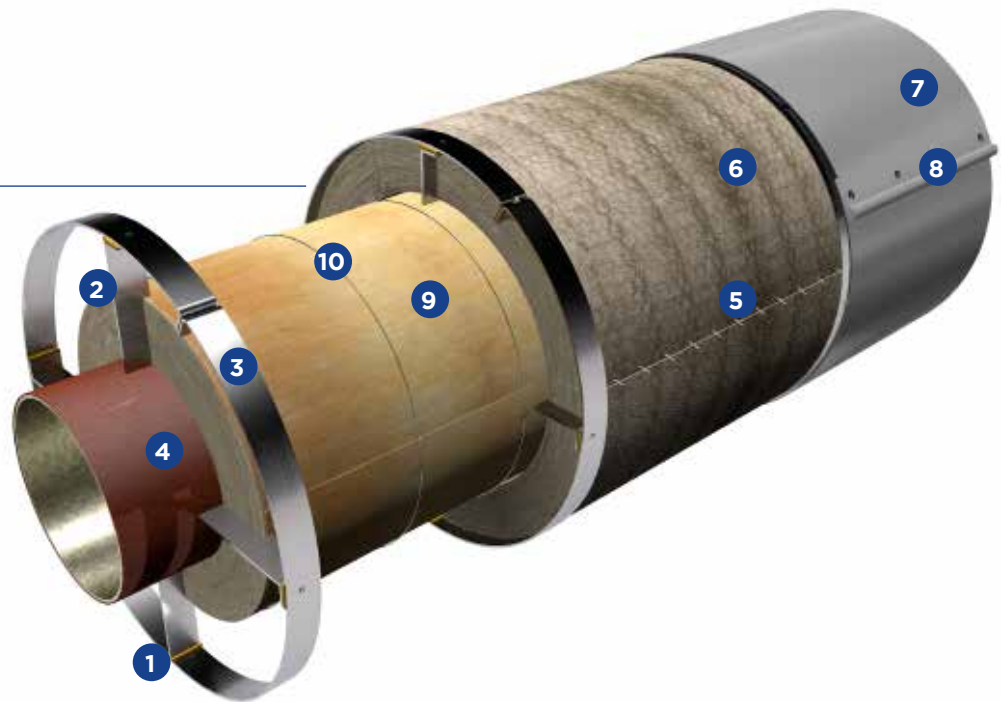

### 3.4.3 Curved sections

When pipes are insulated with ISOVER TECH Pipe Sections, elbows are insulated by cutting the pipe sections into segments adapted to the size and surface of the elbow, to then proceed to slightly open the longitudinal cut of the pipe section to fit it on the pipe, positioning the longitudinal cuts at the bottom.

The cutting angle for the segments will be determined by the elbow radius of curvature

Then each segment will be secured in place by at least one wire lacing around the perimeter of the elbow and tightly intertwining and embedding the ends of the wire in the insulation itself.

For pipes insulated with ISOVER TECH Wired Mat solutions, elbow insulation must be done by means of pieces of wired mat (in the shape of a fish) properly cut using templates.

For a tight insulation system, individual wired mat sections will be butt-jointed, the joints shall be applied staggered and shall be tacked with a 0,5-1 mm diameter stainless steel wire or stainless steel blanket hooks at a pitch of 50 mm. In the case of galvanized wire blankets, galvanized blanket hooks shall be used.

For fastening of wired mats stainless steel bands shall be used with minimum dimensions 12 mm x 0.5 mm and at intervals of  $\leq 300$  mm

For elbows of diameter greater than 24" fastening of the pipe sections or wired mats pieces should be reinforced by way of galvanised or stainless steel straps at each end of the elbow at least.

The insulation thickness shall be the same as that on the adjoining piping.

Figure 5. PIPING – Elbow  
(Wired Mat)

1. Thick gasket or glass fabric
2. Spacer
3. Supporting ring
4. Pipe
5. Tacking thread
6. Wired mat
7. Cladding
8. Screws, selftappers or blind rivets



### 3.4.4 Flanges and valves

It is important to note that leaving valves, flanges and other fittings uninsulated, leads to an increase in heat losses and compromises the maintenance of temperature limits affecting negatively the proper functioning of the different industrial processes.

Box covers shall normally be used to insulate flanges and valves. Such boxes may also be constructed to insulate several small items of equipment confined within a small space. Box covers shall be built in at least two parts using the same grade of metal specified for the cladding of the adjacent pipework.

The inner side of the box will be covered with TECH Wired Mat/U TECH Wired Mat, which is secured using pins, Z-shaped steel pieces or landing collars. Both parts of the box will be secured using quick-release fasteners (the number of fasteners will be subject to the size of the casing). For a better thermal performance, and before installing the box with the attached insulation mat, it is recommended to use loose wool to fill the inner space and remaining gaps.

The insulation thickness shall be the same as that on the adjoining piping.

Covers shall be installed after the adjacent pipework insulation has been completed

Insulation on pipe work shall be stopped short of flanges and valve joints (30mm minimum) to facilitate the withdrawal of flange bolts without disturbing the existing insulation on the adjacent pipework. At such points, adequate provision should be provided to prevent the ingress of moisture, by weatherproofing and sealing. Especially for external pipework, watertight seals may be required at the termination of the pipework insulation/cladding, between the cover and the pipework cladding and on the box closure seams.

When weatherproofing is required, box covers should be designed such that the top plate sheds water, and joints should be of a lockform design.

Boxes having a drain hole at the lowest point could normally be used to allow drainage of liquids preventing corrosion under insulation issues among others.

Removable insulation boxes shall overlap the adjacent pipeline insulation over a distance of at least the pipe insulation thickness with a minimum of 50 mm. Removal of the cover should not compromise integrity of adjacent insulation

Figure 6. PIPING – Valve

1. *Wired mat*
2. *Metal box*
3. *Valve*
4. *Quick release fasteners*

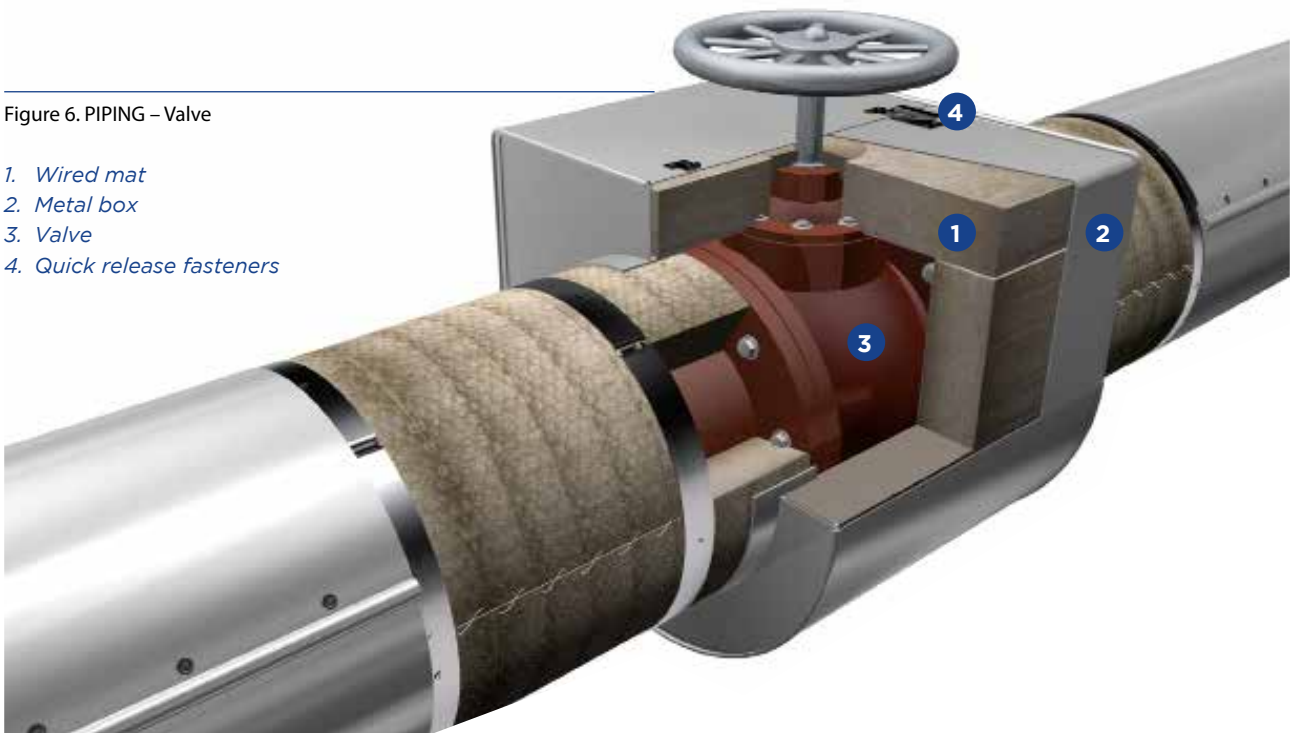

Figure 7. PIPING – Flange

1. Wired mat
2. Metal box
3. Flange
4. Quick release fasteners



### 3.4.5 Pipes with traced lines

For externally steam traced lines, the set formed by the main pipe and the traced line shall be completely encircled with a galvanised or stainless steel electro-welded mesh, with the joints stitched with galvanised or stainless steel wire. In those cases, where there are several traced lines, the steel mesh could be replaced by an inner metal cladding.

For electrical heat tracing systems, the set formed by the main pipe and the traced lines should be completely encircled with an aluminum foil before placing the insulation.

The main purpose of these protection systems is to avoid having insulation material in the gap between the main pipe and the traced lines, with a consequent reduction in the required heat transmission of the heat tracing system.

The standard method used for flexible insulation of medium and big diameter tracing systems is usually the installation of wired mats. ISOVER's mineral wool mat solutions, TECH Wired Mat and U TECH Wired Mat, are stitched with galvanized wire on hexagonal galvanized wire mesh for flexible and ease installation especially on big diameter pipes. On request they are also available with reinforced aluminium facing as well as with stainless steel wire and wire mesh (recommended for pipes operating at > 400 °C).

The wired mats shall be previously cut to a size equal to the "outer diameter of the set formed by the main pipe and the traced lines + 2 x insulation thickness" and subsequently placed on the pipe.

For a tight insulation system, individual sections will be butt-jointed, the joints shall be applied staggered and shall be tacked with a 0,5-1 mm diameter stainless steel wire or stainless steel blanket hooks at a pitch of 50 mm. In the case of galvanized wire blankets, galvanized blanket hooks shall be used. The longitudinal joints of the insulation will be positioned in the opposing side of the traced line.

For fastening of wired mats stainless steel bands shall be used with minimum dimensions 12 mm x 0.5 mm and at intervals of  $\leq 300$  mm.

In case steam traced piping will be insulated with pipe sections, oversized pipe sections shall be used with diameters equal to the diameters of the pipe plus the traced lines.

The first step is slightly open the longitudinal cut of the pipe section to fit it on the traced system and then each piece must be secured in place by placing steel wire lacings (0.5 mm diameter) around the perimeter of the pipe section and tightly intertwining and embedding the ends in the insulation itself. The maximum recommended spacing between wire lacings will be 300 mm, leaving at least 3 lacings per linear meter.

Figure 8. PIPING – Straight Pipe – Tracing 1 element

1. Main pipe
2. Heat tracing
3. Wired stretched mesh
4. Wired mat
5. Stainless steel bangs
6. Tacking thread
7. Cladding
8. Screws, selftappers or blind rivets

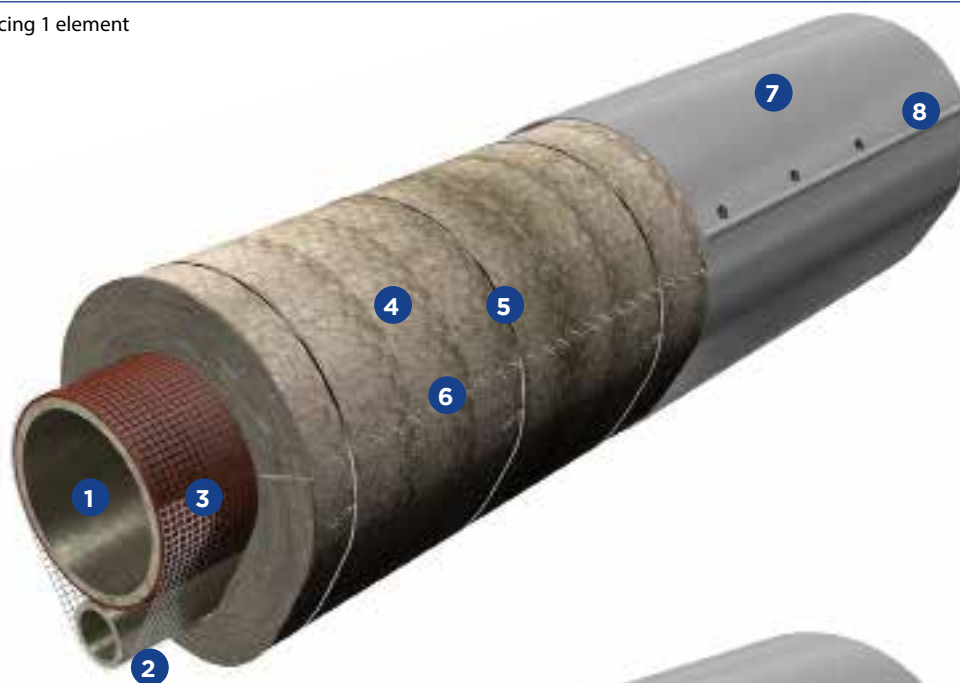
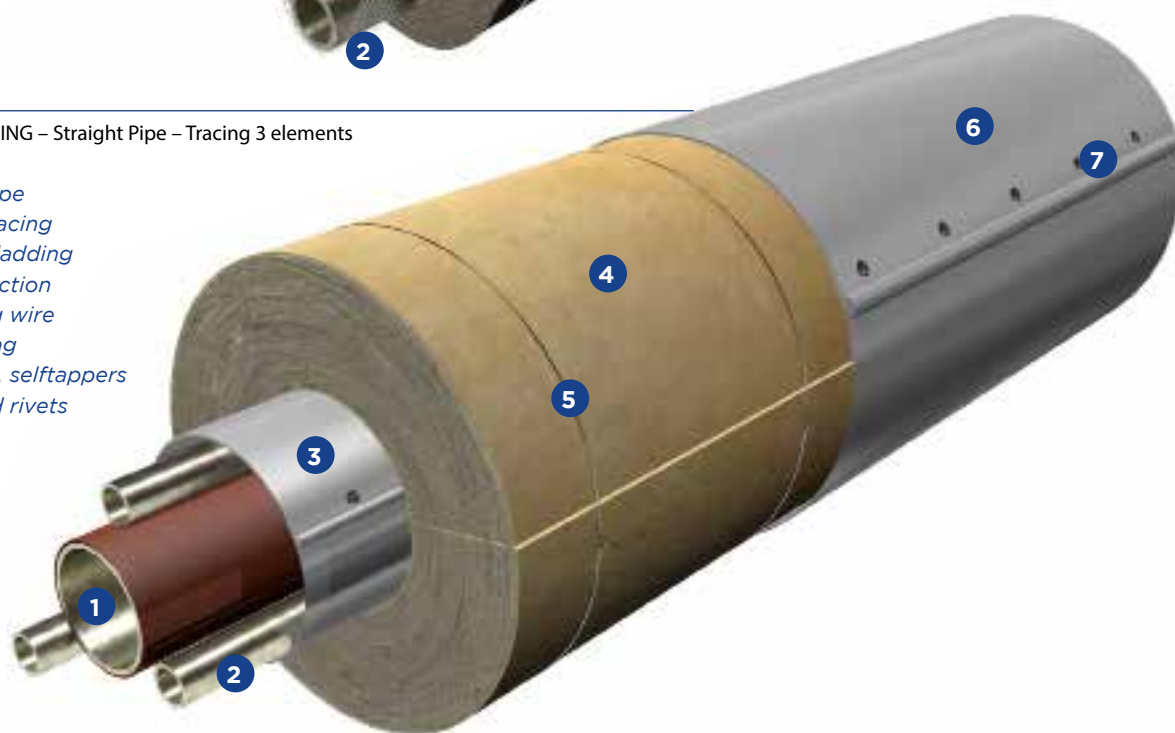

Figure 9. PIPING – Straight Pipe – Tracing 3 elements

1. Main pipe
2. Heat tracing
3. Inner cladding
4. Pipe section
5. Binding wire
6. Cladding
7. Screws, selftappers or blind rivets



### 3.4.6 Other pipe components

In industrial installations, there are other components on which thermal insulation needs to be installed. These include tees, pipe supports, concentric reducers and expansion joints. To install mineral wool insulation on these components, previous guidance given for pipes should be followed.

As a general rule the insulation thickness shall be the same as that on the adjoining piping.

Below some drawings are shown by way of example:

Figure 10. PIPING – T-Piece

1. Pipe
2. Spacer
3. Supporting ring
4. Thick gasket or glass fabric
5. Wired mat
6. Tacking thread
7. Cladding
8. Screws, selftappers or blind rivets

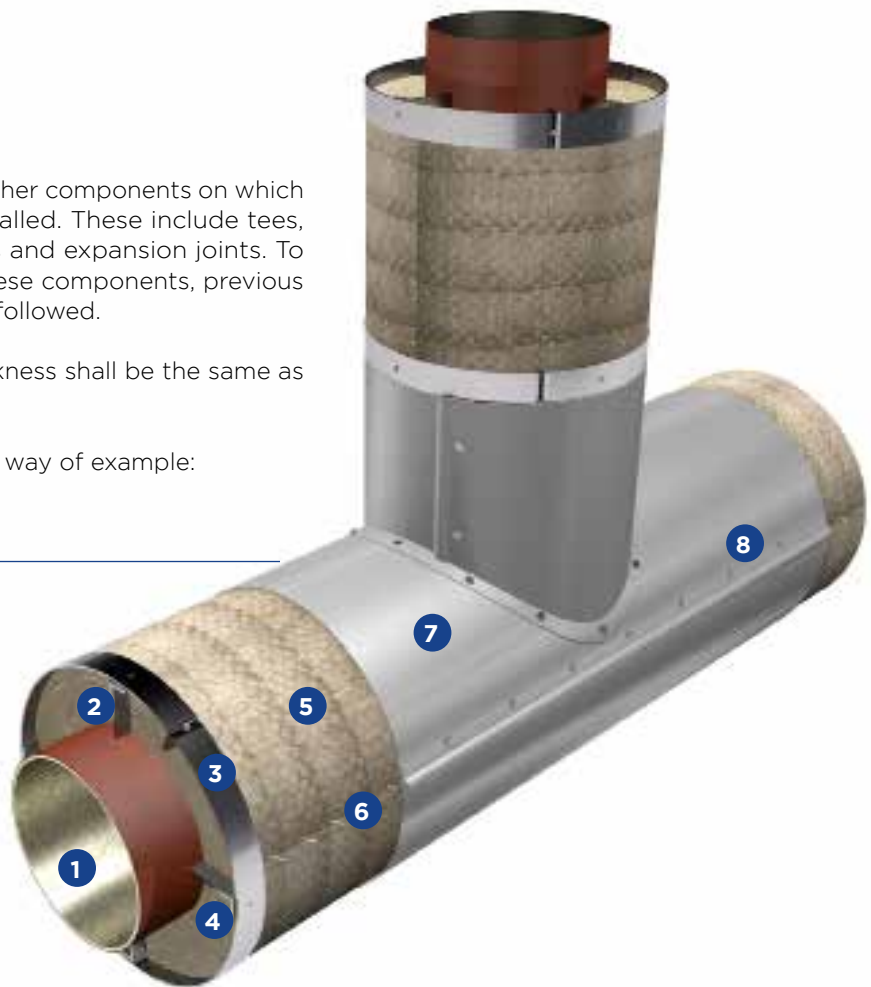

Figure 11. PIPING – Support

1. Pipe
2. Spacer
3. Supporting ring
4. Thick gasket or glass fabric
5. Wired mat
6. Tacking thread
7. Cladding
8. Screws, selftappers or blind rivets

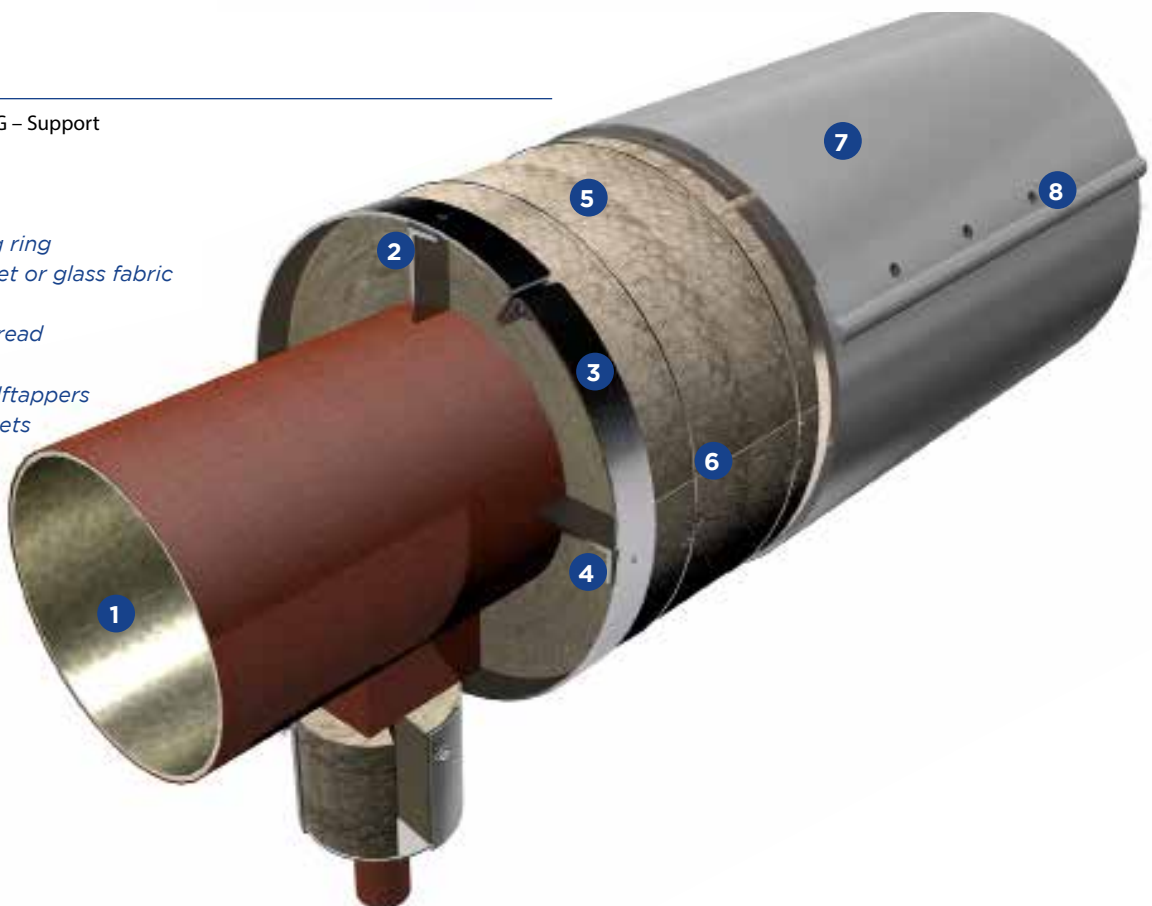

Figure 12. PIPING – Concentric Reducer Bellow

1. Pipe
2. Spacer
3. Supporting ring
4. Thick gasket or glass fabric
5. Wired mat
6. Tacking thread
7. Cladding
8. Screws, selftappers or blind rivets

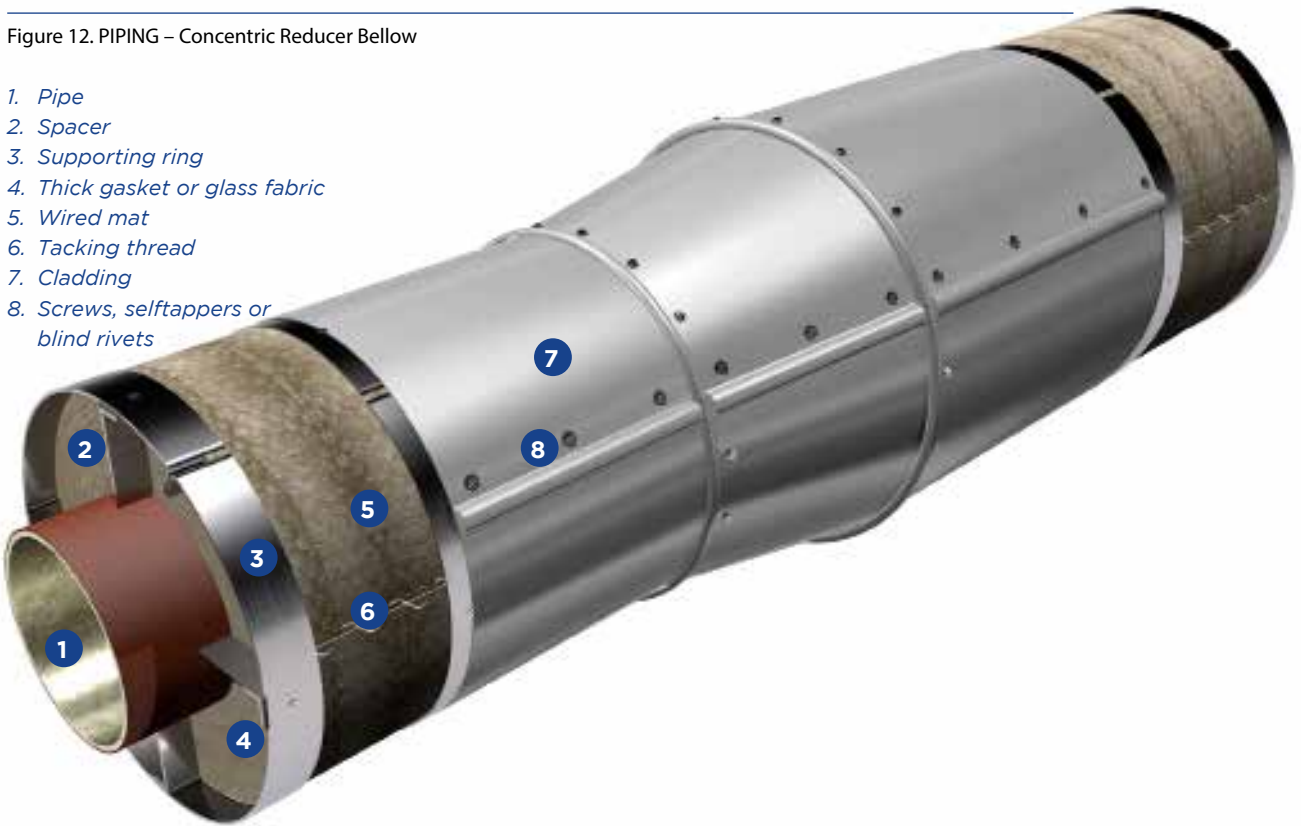
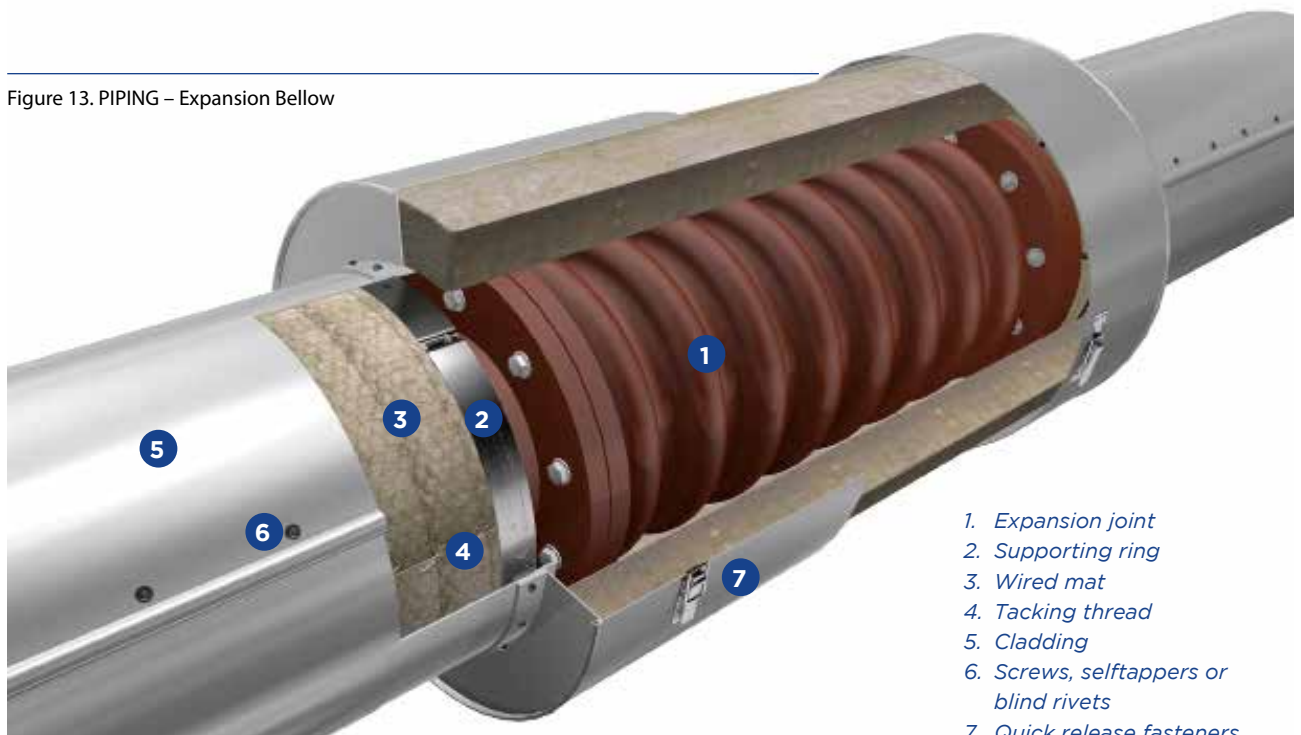

Figure 13. PIPING – Expansion Bellow



1. Expansion joint
2. Supporting ring
3. Wired mat
4. Tacking thread
5. Cladding
6. Screws, selftappers or blind rivets
7. Quick release fasteners

### 3.5 Insulation systems for equipment and tanks

Depending on the size, geometry and type of material of the equipment, the type of insulation, the type of cladding and also the particular specifications for thermal insulation, there are several specific details to take into account in the installation process.

ISOVER offers a wide range of Glass Wool, Stone Wool and ULTIMATE solutions specially designed for industrial equipment and tanks in the form of mats, rolls and slabs.

The best choice will depend on each particular case and will be subjected to several factors including the working temperature, size of the equipment or ease of assembly among others.

Prior to the insulation, spacer rings will be placed when necessary as supporting structure for the insulation and mechanical protection and to keep a uniform distance between the cladding and the pipe surface.

When applying brackets or welded supports the insulation system shall be applied after installation and shall be adapted to the type of support.

When the required thickness of the insulation is greater than 100mm or when the operating temperatures are above 300°C, it is normally recommended to use several layers of insulation which number will depend on the final thickness required. In multi-layer insulation systems, the circumferential joints layers shall be staggered with an overlap of at least 150 mm at the joints.

As a general rule at equipment mats shall be applied horizontally with staggered vertical joints and slabs shall be installed vertically with staggered circumferential joints.

It is recommended to install slabs preferably on components with flat surfaces or curved surfaces with large radius of curvature, and wired mats on smaller components where the existence of stiffeners, supports or other components makes installation easier. For applications with high demands in terms of compressive strength such as in tank roofs slabs are also recommended.

For a tight insulation system, individual sections will be butt-jointed and all the joints shall be applied staggered. ISOVER's mineral wool mat solutions are stitched with galvanized wire on hexagonal galvanized wire mesh for flexible and ease installation, the joints shall be tacked with a 0,5-1 mm diameter stainless steel wire or stainless steel blanket hooks at a pitch of 50 mm. In the case of galvanized wire blankets, galvanized blanket hooks shall be used.

For insulation of heads of vessels, whether they are conical or domed the mats or panels will be cut to fit the surface to be insulated. Insulation will be held in

place with binding wire and secured by radial bands fixed to a floating ring at the center of the head, and a fixed support ring on the shell around the perimeter of the head. Spacing of the bands at the support ring should not exceed 150 mm. Metal cladding on heads of vessels should be fabricated with an overlapped, orange peel design, with overlaps arranged to shed water. In the case of external locations, the cladding should be sealed to prevent moisture entering under the vertical cladding.

When the fixed roofs of hot tanks require insulation, a framework should be erected on the roof to provide a positive means of attachment for the cladding material. The transition from the shell to the roof should be designed to be weatherproof.

In many cases, the insulation is attached using spikes previously welded to the shell of the component to be insulated, driving the different insulating layers onto these spikes and placing a metallic spring washer on the last insulating layer.

For fastening of wired mats and slabs stainless steel bands should be used with minimum dimensions 19 mm x 0.5 mm and at intervals of  $\leq 300$  mm.

On equipment with skirts, the insulation will be extended by a length at least four times the required insulation thickness.

For large diameter equipment, steel strapping with springs is recommended to prevent the fall of metallic sheets in the event of strong wind or storms, and also enable expansion of the tank. The cladding should be fully weatherproofed and allowances made for expansion and contraction of each vessel in service.

In the case of pipe inlets/outlets, connections, inspection ports, manholes, supports, lifting lugs or areas where a break in the insulation is anticipated, special care will be taken to ensure the continuity of the insulation, that there are no thermal bridges and all surfaces and joints in the cladding are arranged to shed water.

Removable boxes should normally be used to insulate inspection ports, drains, manholes, blind flanges, etc.. Box covers are built in at least two parts using the same grade of metal specified for the cladding of the adjacent component. The inner side of the box will be covered with TECH Wired Mat/U TECH Wired Mat, which is secured using pins, Z-shaped steel pieces or landing collars. Both parts of the box will be secured using quick-release fasteners (the number of fasteners will be subject to the size of the casing). For a better thermal performance, and before installing the box with the attached insulation mat, it is recommended to use loose wool to fill the inner space and remaining gaps.

Some detailed illustrations of horizontal and vertical vessels, columns, tanks, boilers and exhaust ducts and stacks are presented below.

Figure 14. HORIZONTAL VESSEL

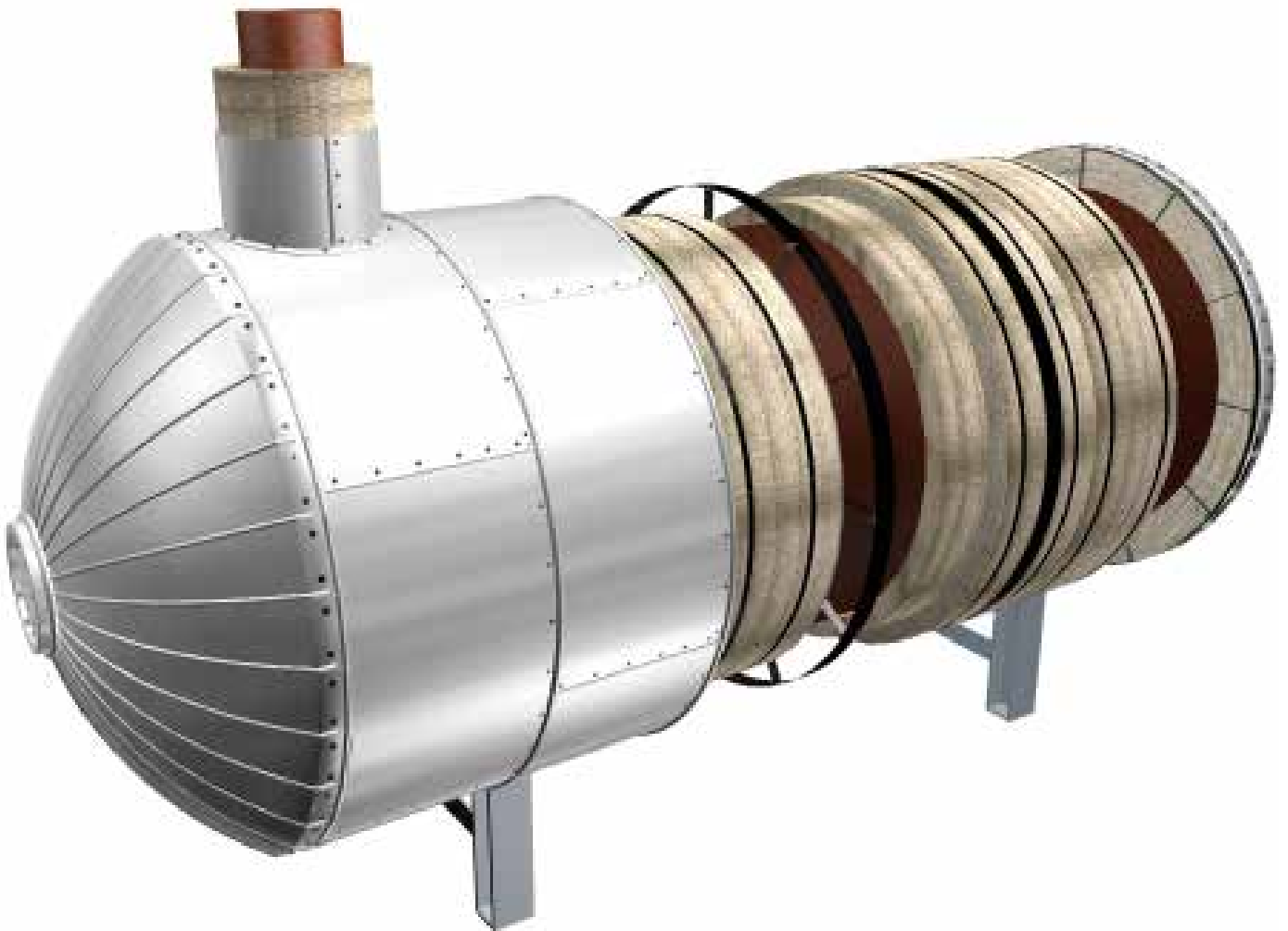

Figure 15. VERTICAL VESSEL



Figure 16. VERTICAL VESSEL DETAIL 1



Figure 17. VERTICAL VESSEL DETAIL 2



Figure 18. COLUMN



Figure 19. COLUMN DETAIL 1

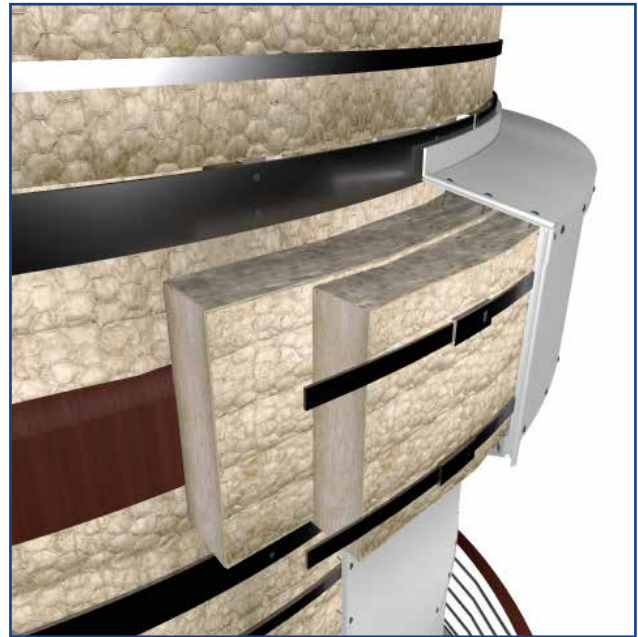

Figure 20. COLUMN DETAIL 2

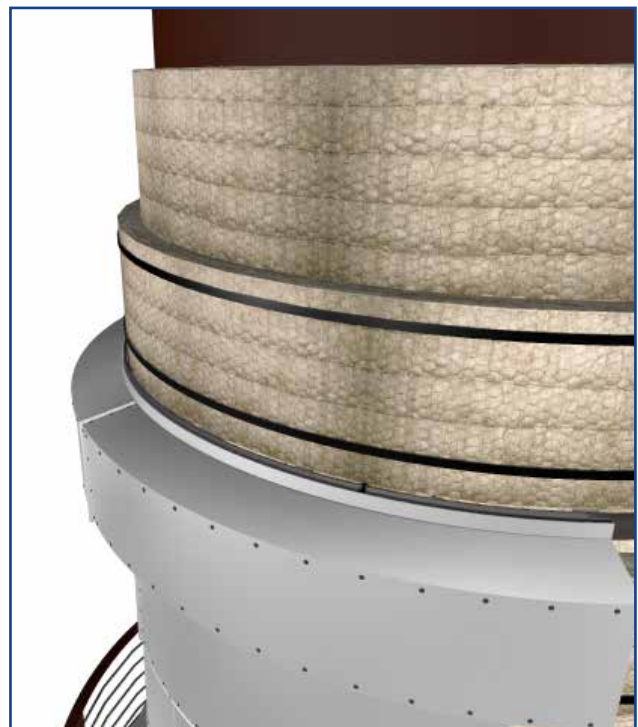

Figure 21. STORAGE TANK (Wired Mats)

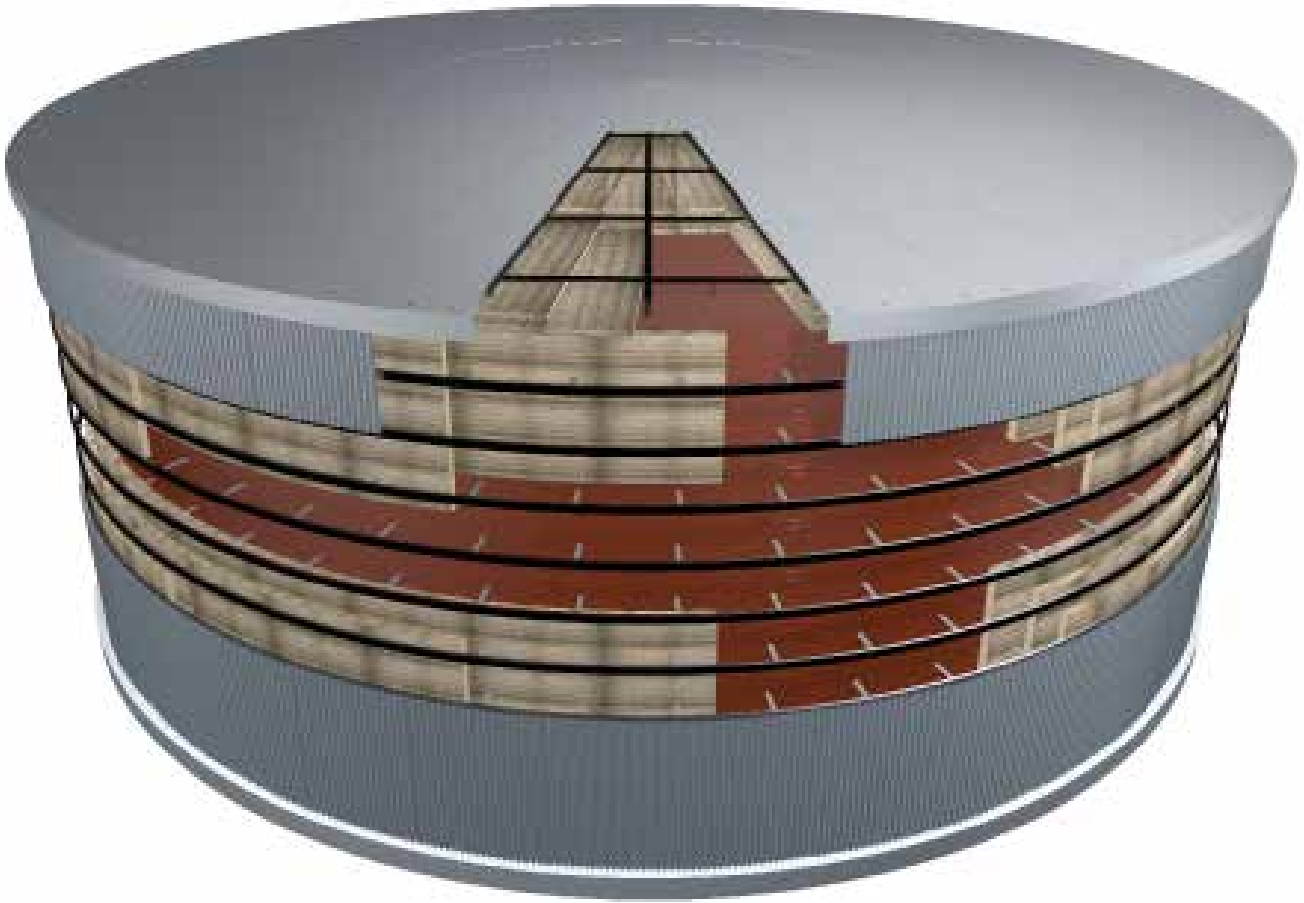

Figure 22. STORAGE TANK DETAIL 1 (Wired Mats)

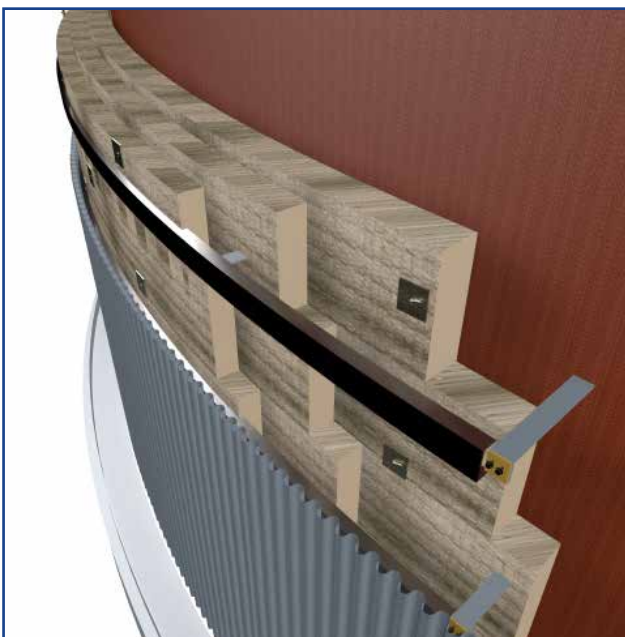

Figure 23. STORAGE TANK DETAIL 2 (Wired Mats)

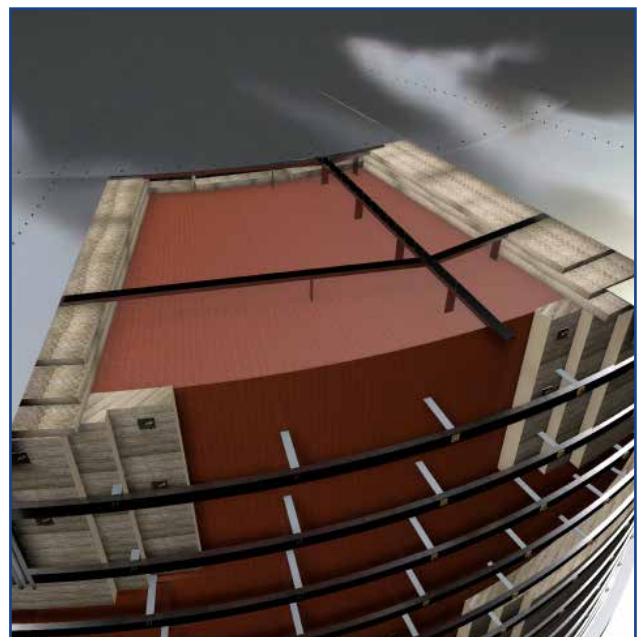

Figure 24. STORAGE TANK (Panels)

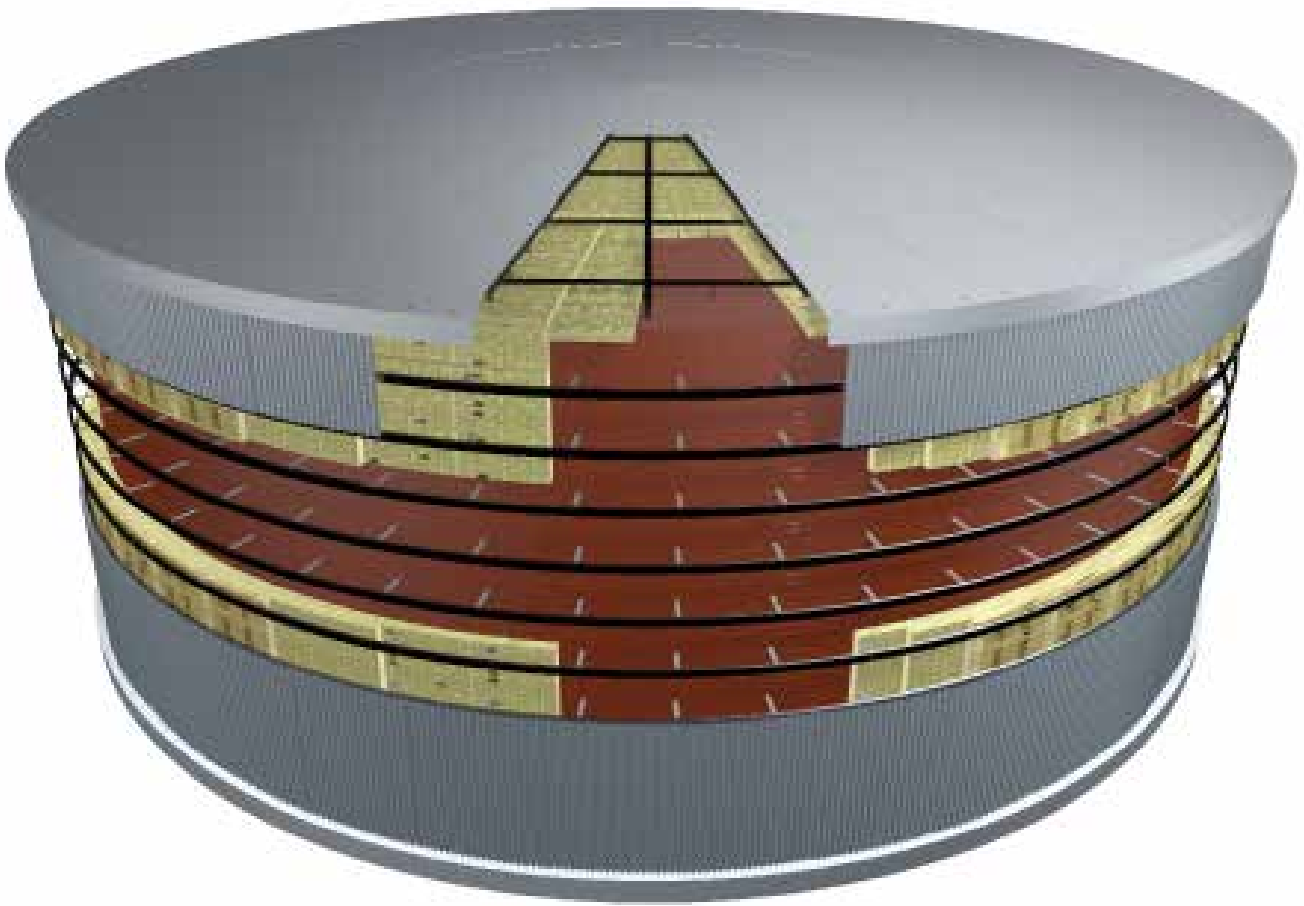

Figure 25. STORAGE TANK DETAIL 1 (Panels)

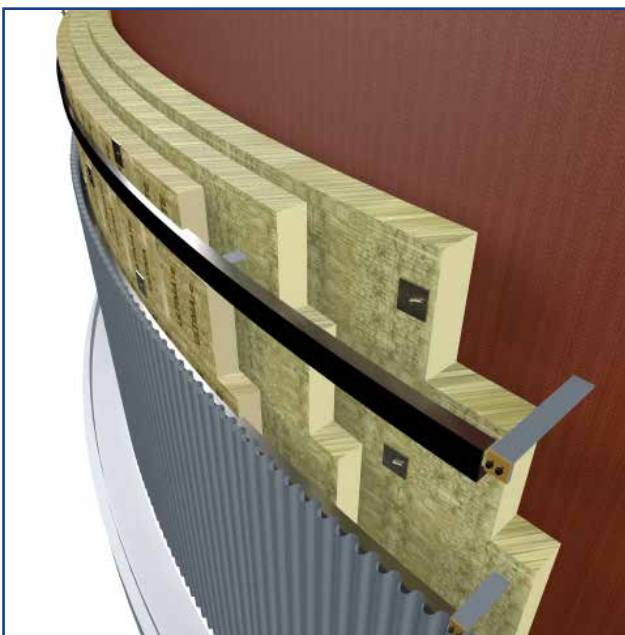

Figure 26. STORAGE TANK DETAIL 2 (Panels)

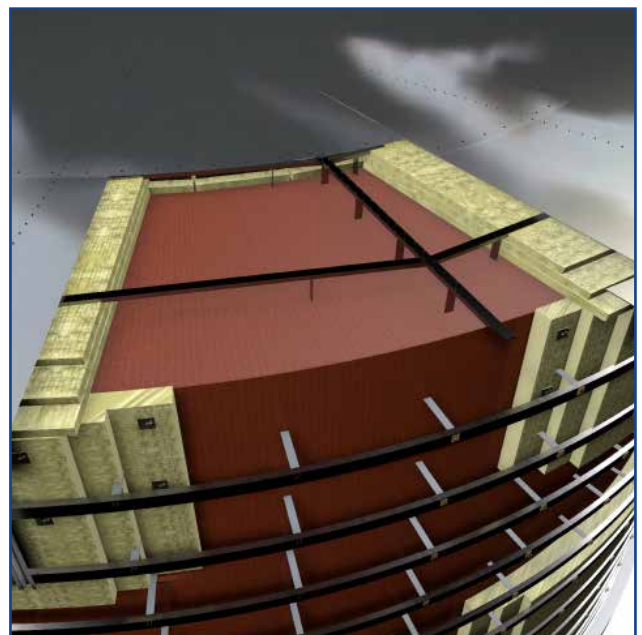



Figure 27. BOILER

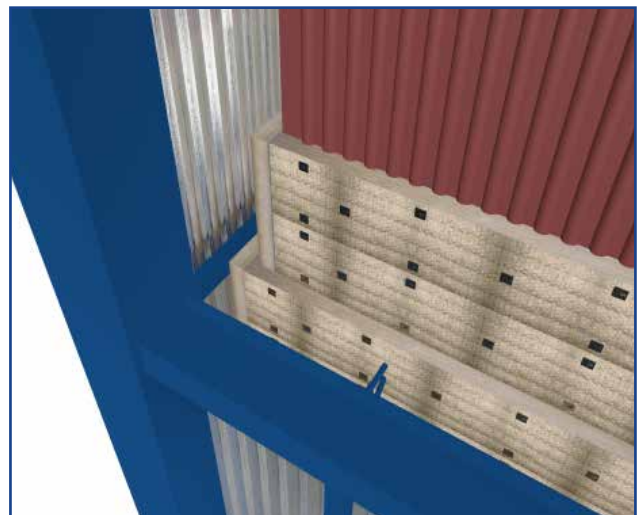

Figure 28. BOILER DETAIL 1

Figure 29. EXHAUST DUCT

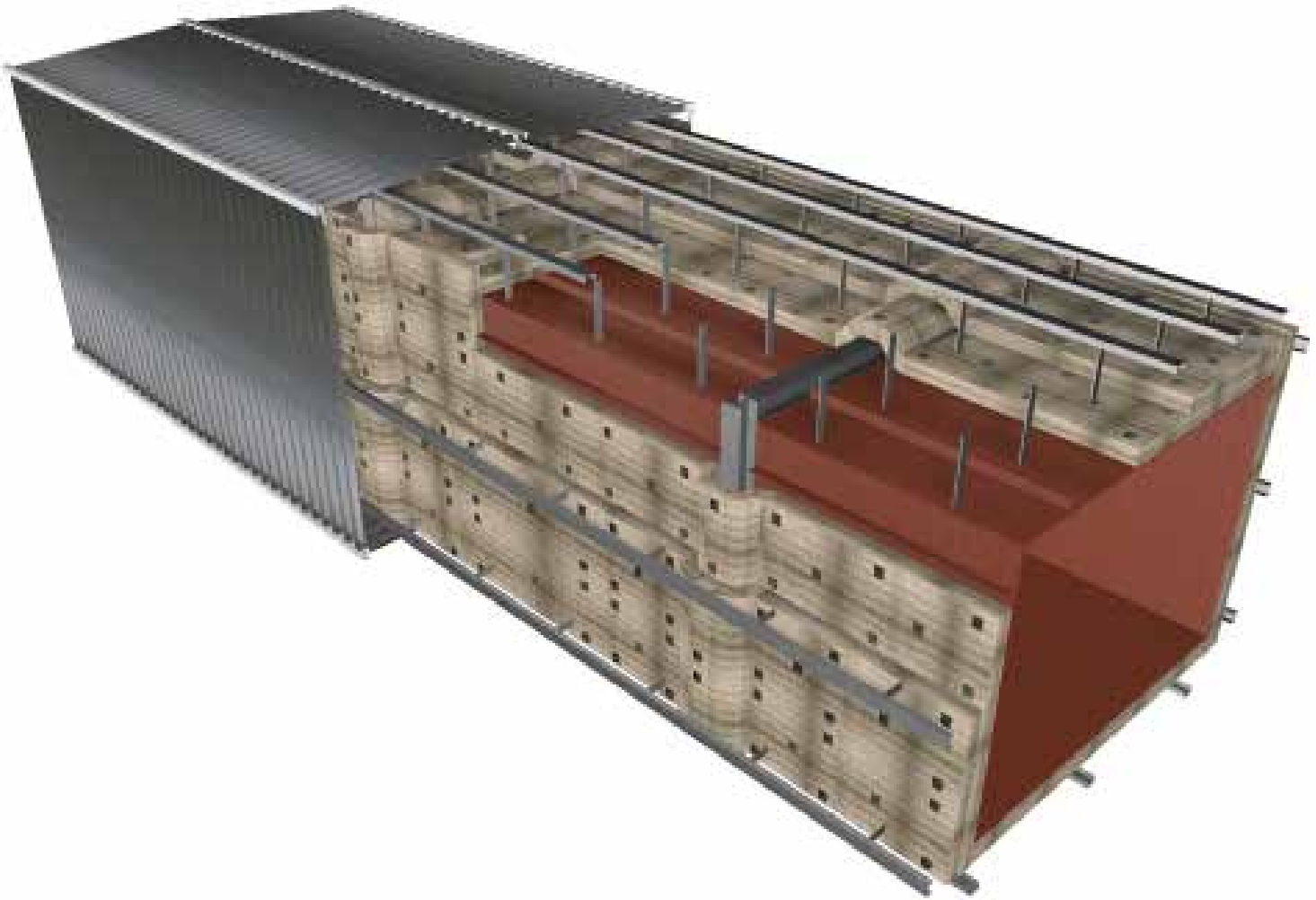

Figure 30. EXHAUST DUCT DETAIL 1

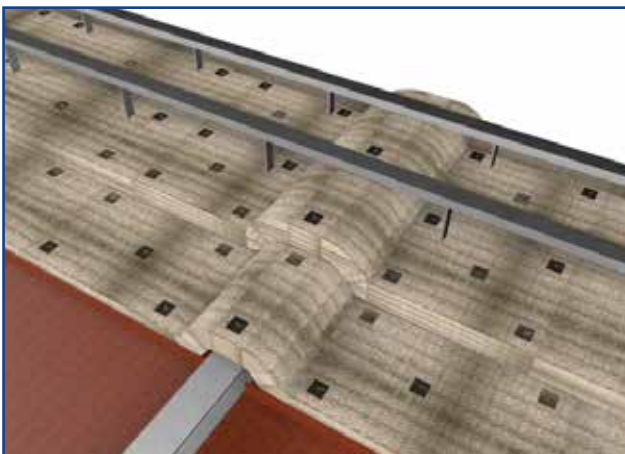

Figure 31. EXHAUST DUCT DETAIL 2

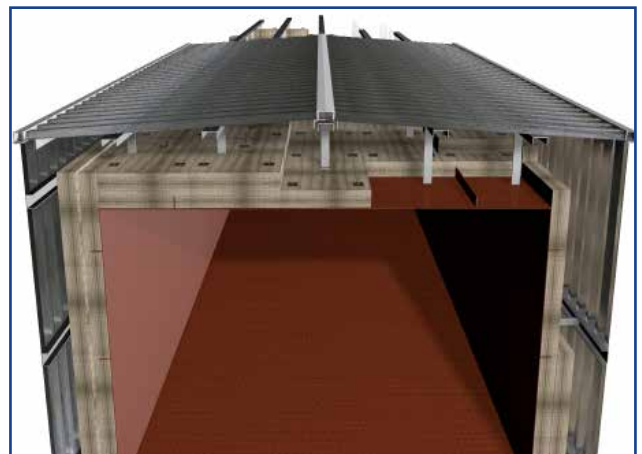
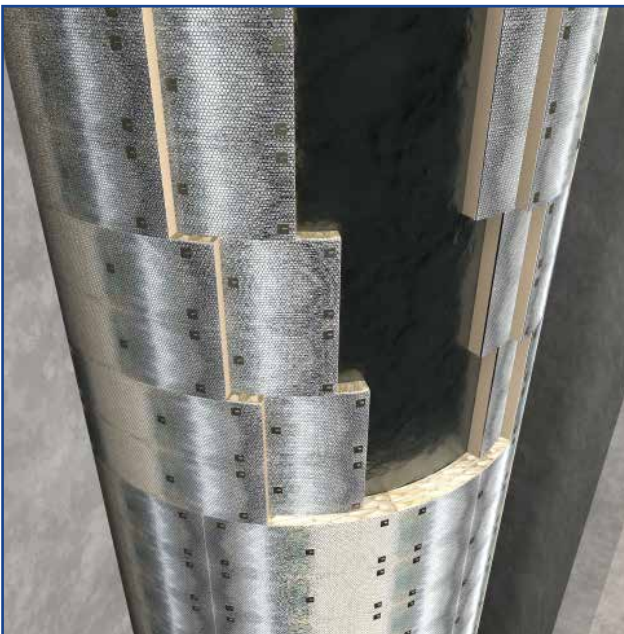

Figure 32. EXHAUST STACK



FIGURE 33. EXHAUST STACK DETAIL 1



## 3.6 Quality Inspection Plan

It is important to draw up a work quality plan to be approved by the client, in which the minimum requirements to be met by the contractor are laid down. As a minimum, assembly procedures, inspection points and a quality certificate for the materials used should be incorporated. For quality control of the installation and to guarantee correct installation of the thermal insulation, at least the following check points and acceptance criteria will be used for the thermal insulation of pipes and equipment.

Some examples of acceptance criteria and check points are presented below

### 3.6.1. Piping

#### a) Spacer rings

Installation of spacers where appropriate. Dimension check. Height 33 mm and 310 mm apart.

#### b) Insulating material

- Type and thickness of theoretical insulation. Dimension check. Corresponds to the specifications.
- Final thickness of the insulation. Dimension check. Installed thickness = thickness specified (0, +10 mm)
- Fastening of wire lacing. Visual inspection. Maximum distance 300 mm.

#### c) Metallic protection

- Type and thickness of the material. Execution of beads and overlaps. Dimension check. As per specification.
- Secured using screws/rivets. Visual inspection.

#### d) General finish. Visual inspection. No impact or damage.

Criteria:

	CHECK POINTS	ACCEPTANCE CRITERIA
<b>Insulation support</b>	Positioning of spacers where appropriate (height and separation)	As per specifications
<b>Insulating material</b>	Type and thickness of theoretical insulation	As per specifications
	Final thickness of the insulation	Installed thickness = thickness specified (0, +10 mm)
	Fastening will be wire clamped	Maximum distance 300 mm
<b>Metallic protection</b>	Type and thickness of the material. Execution of beads and overlaps	As per specifications
	Secured using screws/rivets	Approx. every 250 mm
<b>Final finish</b>	No impact or damage	

All of these criteria will be recorded in the corresponding check point record. As a minimum, each type of insulation system, each pipe diameter for each type of insulation and at least 40% of all of the insulation installed will be inspected. The figure below shows a standard format for pipe check points.

ISOMETRIC/FLAT:		IDENTIFICATION:			ACCEPTANCE CRITERIA
CHECK POINT	INSPECTION TYPE	PA/PE	DATE	RESULT	REVIEWED / OBSERVATIONS
Initial state of the pipe	Visual				
Positioning of spacers (height and separation)	Dimensional				
Type and thickness of theoretical insulation	Dimensional				
Securing of insulation (wire)	Visual				
Insulation butt joints	Visual				
Type and thickness of the material. Execution of beads and overlaps	Dimensional				
Securing of metallic layer with screws/rivets	Visual				
General inspection	Visual				
OBSERVATIONS:			INSPECTION D:	INSPECTION BY:	
			Date:	Date:	

### 3.6.2. Equipment

#### a) Spacers

Installation of spacers where appropriate. Dimension check. Height 33 mm and 310 mm apart. Distance between separators (e.g. every 950 mm, depending on specification).

#### b) Insulating material

- Type and thickness of theoretical insulation. Dimension check. Corresponds to the specifications.
- Final thickness of the insulation. Dimension check. Installed thickness = thickness specified (0, +10 mm)
- Securing of the wired mat, stitching the mesh and attaching the spacers. Visual inspection. There are no spaces without insulation.

#### c) Metallic protection

- Type and thickness of the material. Execution of beads and overlaps. Dimension check. As per specification.
- Secured using screws/rivets. Visual inspection. Approx. every 300 mm.

#### d) General finish. Visual inspection. No impact or damage

Criteria:

	CHECK POINTS	ACCEPTANCE CRITERIA
<b>Insulation support</b>	Positioning of spacers (height and separation)	950 mm $\pm$ 10 mm; Depending on specification
<b>Insulating material</b>	Type and thickness of theoretical insulation	As per specifications
	Final thickness of the insulation is that specified	Installed thickness = thickness specified (0, +10 mm)
	Securing of the mat, stitching the mesh and attaching the spacers	There are no spaces without insulation
<b>Metallic protection</b>	Type and thickness of the material as per specification	As per specifications
	Secured using screws/POP rivets	Approx. every 300 mm
<b>Final finish</b>	No impact or damage	

All of these criteria will be recorded in the corresponding check point record. 100% of the thermal insulation of equipment will be inspected. The figure below shows a standard format for pipe check points.

ISOMETRIC/FLAT:		IDENTIFICATION:			ACCEPTANCE CRITERIA
CHECK POINT	INSPECTION TYPE	PA/PE	DATE	RESULT	REVIEWED / OBSERVATIONS
<b>Initial state of the pipe</b>	Visual				
<b>Positioning of spacers (height and separation)</b>	Dimensional				
<b>Type and thickness of theoretical insulation</b>	Dimensional				
<b>Securing of the mat, stitching the mesh and attaching the spacers</b>	Visual				
<b>Insulation butt joints</b>	Visual				
<b>Type and thickness of the material. Execution of beads and overlaps</b>	Dimensional				
<b>Securing of metallic layer with screws/POP rivets</b>	Visual				
<b>General inspection</b>	Visual				

<b>OBSERVATIONS:</b>	<b>INSPECTION D:</b>	<b>INSPECTION BY:</b>
	<b>Date:</b>	<b>Date:</b>

### 3.6.3. Works Supervision

Works Supervision (external company or end user) may ask for the tests that it deems necessary in accordance with the Project Specifications and the Codes, Regulations and Standards that it considers applicable.

It may ask the Contractor during performance of the works for the official certificates of the materials that prove the compliance of these with the technical specifications of the materials installed. All of the certificates of conformity should be included in the Quality Guarantee Documentation. However, it will be necessary to produce a Quality Plan for installation of thermal insulation, which includes all of the procedures listed, acceptance criteria, list of check points, material certificates and any other documentation that the end user or customer deems necessary.



## 4 Corrosion Under Insulation (CUI)

### 4.1 Definitions

#### 4.1.1 Humidity, moisture

On earth, water can be in solid (ice), liquid or gaseous (vapour) state.

Due to thermodynamic equilibrium, there is always some water vapour in the air. It is important to take into account the level of moisture in and around the insulated system when designing insulation systems, both for insulation performance and to prevent corrosion (see section 4.3 "Corrosion Under Insulation").

#### 4.1.2 Absolute and relative humidity

When talking of the gaseous state of water (i.e. water vapour), two main values are often referred to: absolute humidity and relative humidity.

**Absolute humidity** is the numerical measurement of the amount of water vapour or moisture in a given atmospheric environment, irrespective of temperature. It is expressed as grammes of moisture per cubic metre of air ( $\text{g}/\text{m}^3$ ).

Absolute humidity is a vital factor impacting the occurrence of corrosion in a metal. Atmospheric corrosion is a chemical reaction that requires water to take place. The absolute humidity is directly proportional to the likelihood and severity of corrosion.

**Relative humidity** may be defined as the ratio of the water vapour density (mass per unit volume) to the saturation water vapour density at a given temperature and is usually expressed in percentage. The relative humidity of air depends on temperature and the pressure of the system of interest. Relative humidity does not tell us how much water vapour is in the air, but what percentage of the maximum vapour pressure has been reached.

Corrosion can be accelerated by high relative humidity. Corrosion is slowed down significantly when the relative humidity is below 50 %. Relative humidity is useful only when measured at the surface.

#### 4.1.3 Water vapour transmission

The water vapour transmission rate (WVTR) measures the passage of water vapour through a substance of a given unit area and unit time. Controlling the water vapour transmission rate is important because varying working temperatures may lead to condensation and the formation of moisture, which can cause corrosion.

The water vapour transmission rate is also known as the moisture vapour transmission rate (MVTR). Controlling moisture is important in many industries.

The moisture vapour transmission rate is a key measurement unit used to determine the degree to which a film layer can resist moisture infiltration. This is of particular importance when selecting a coating or lining for corrosion prevention on a metallic surface.

Standards (ISO 12572 and EN 12086) provide methods in order to determine under isothermal conditions the water vapour permeance, the vapour permeability and the water vapour transmission properties.

#### 4.1.4 Condensation and dew point

In the normal atmosphere, there is some water vapour inside the air (atmospheric moisture).

While the absolute humidity in the air mainly depends on the surrounding conditions (for instance, it will rise in the bathroom after taking a shower), the relative humidity will also depend on the air temperature and barometric air pressure.

When the relative humidity equals 100 %, it means the air is saturated with vapour, and then it is not possible to add any more gaseous water vapour, so liquid vapour will appear. In the atmosphere this is what happens in clouds, or in fog. On the ground or on objects, condensation appears.

Condensation exposure refers to an exposure where the surface is almost constantly exposed to saturated air, accompanied by repeated or continuous condensation. Continuous exposure of surfaces to condensation environments promotes the corrosion of surfaces.



The dew point is the temperature where air is no longer capable of holding the water vapour that is contained within it. At the dew point temperature, water vapour condenses into liquid water. At all times, the dew point temperature is equal to or less than the air temperature.

Since moisture is produced at the dew point, knowledge of this weather element helps in the selection of metals.

Dew point corrosion is corrosion damage that occurs when the air reaches a temperature at which the evaporating and condensing rate of its moisture content are the same at a constant pressure. This is experienced when the air is humid, foggy, moist, sticky and misty.

## 4.2 Insulation products behaviour

### 4.2.1 Wet insulation performance

The performances of insulation products are usually declared for products in "dry" conditions, with a relative humidity of around 50 %.

But what happens when the insulation is in contact (accidentally) with liquid water?

Determination of the thermal performance of a "wet" insulation product is complex, because it implies not only "simple" heat transfer but also mass flow (liquid and gaseous water inside the insulation) and phase changes (condensation or evaporation of water involves latent heat releases).

Depending on the ambient conditions, the porosity and the permeability of the material, the standard ISO 23993 gives a conversion factor established for the different influences for the thermal performance applicable for building equipment and for industrial applications.

An important parameter is the hygroscopic properties of insulation.

Considering the hygroscopic properties of mineral wools, the design of an insulation system is done accordingly, keeping the whole system as dry as possible in order to avoid corrosion under insulation and keep a good thermal performance.

But looking at this single product parameter is not enough, since water can get inside the insulation system through installation weak points.

If there is moisture in the insulation system, the causes of this moisture must be found and corrected.

### 4.2.2 Water ingress

There are many reasons for water ingress inside an insulation system:

- liquid water can come from rain water, fire deluge systems, wash water, leaks in the installation, etc.
- liquid water can also come from water vapour that finally condenses on the insulated equipment.

In order to limit such water ingress, it is recommended to design an insulation system to be as waterproof as possible, by installing weather protective cladding, a moisture barrier, caulking (sealing of areas where there are penetrations through the insulation, such as ladder supports, gauge connections, nozzles, and so forth).

But one has to keep in mind that, in real life, completely avoiding water ingress is almost impossible. Even with a watertight product like cellular glass, water can find a way into the small spaces between the insulated equipment (pipes, boilers, valves etc.) and the insulation. Such air cavities can be even bigger when the insulation is not well adjusted to the equipment size, or when heat tracing is also installed.

When liquid water finds its way into this in-between space, because there is a drilled hole somewhere or a crack in the insulation (due to ageing or mechanical impact), this is even more problematic when the insulation is watertight, because this seeped water will not be able to exit easily.

In addition to corrosion under insulation issues, as will be exposed in the next chapter, water ingress can be a dramatic problem when it comes to temperatures below 0 °C (due to process or due to outside temperatures when installation is stopped during winter), since this water will turn into ice, increasing its volume by 10 %, and therefore damaging the insulation system.

**ISOVER advice:** *"Designing damp-proof insulation systems is important, but it is also important to implement solutions to let the liquid water exit in order to avoid water accumulation during lifetime of the installation"*

## 4.3 Corrosion Under Insulation (CUI)

### 4.3.1 What is CUI?

CUI is basically corrosion of the metallic ground (pipe, vessel, chimney, etc.) on which insulation is applied. So when talking of CUI, we first talk of metal corrosion.

Because corrosion is an oxidation reaction, almost every metal can corrode under some circumstances (gold is among the few that do not corrode), but some behaves differently to others.

For instance, aluminium is fairly resistant to damaging corrosion, because it forms a thin oxide layer very quickly, which makes a hard barrier to prevent further oxygen from coming in to interact with the remaining aluminium.

In our jobs, most of the metals that will be insulated are made of steel, and there are many different kinds of steels, some of which corrode more easily than others.

The common mechanism of steel corrosion can be summarised as follows:

---

Electrochemical cell action driven by the energy of oxidation continues the corrosion process

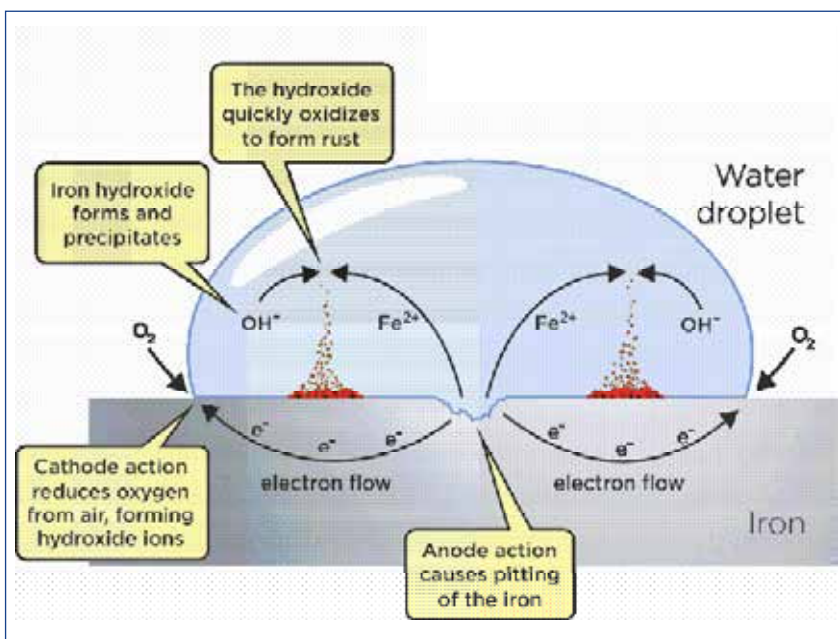

So in order to have such a reaction appearing, you need to have: oxygen (found in the air), liquid water (where both the oxygen and the metallic ions will dissolve), and a metal.



When this metal is iron, the result is commonly called "rust". The main problem of "rust" is that it is not water or oxygen diffusion proof (unlike aluminium oxide for instance). So the corrosion will continue through the thickness of the metal.

All carbon steel, and low quality steel alloys, are subject to this kind of corrosion. And even if the insulation material is usually not the main cause of it, the fact that it hides it (under both the cladding and the insulation material) could lead to very hazardous situations when the pipe or the vessel will leak through the damage done by corroded metal.

**Note:** even stainless steel (austenitic steel) can corrode under specific circumstances!

In this case, we do not talk of "rust", but of another kind of corrosion, called "External Stress Corrosion Cracking" (ESCC). It is less visible but as dangerous as carbon steel CUI. ESCC usually appears when the stainless steel is placed under thermal and/or mechanical stress (high temperature, temperature variations, pressure), and when some chemicals are present on the surface (like chloride).

Ignoring the CUI problem could lead to situations where personal safety, environmental impact and revenue or production loss are at stake.

#### 4.3.2 Critical conditions and what to do

It is almost impossible, in the long run, to avoid corrosion of steel. But the rate of corrosion, and its speed, depends on many environmental parameters.

The critical situations, where CUI will appear fast, are as follows:

- Cyclic temperature process (with temperatures regularly going above and below 100 °C, or with regular “stop and start” of the process);
- Exposure of the insulated system to regular bad weather conditions, with heavy rain;
- High moisture climate (tropical, coastal);
- Chemically aggressive environment (saline mist, high relative humidity, exposure to cleaning agents, etc.).

When all those factors are present, CUI could cause serious problems within less than a year.

In order to mitigate those problems, some solutions exist. They can be combined, and can be used after a CUI risk-based analysis of the system to be insulated: the more risky the situation, the more mitigation solutions should be implemented.

**ISOVER advice:** *The important thing to avoid catastrophic failures due to CUI is always to keep a “system” approach, since no “miracle single solution” exists.*

#### 4.3.3 Protection of the metal

Since CUI is basically the corrosion of the metal lying under the insulation, the first solution to prevent it is to protect this metal from liquid water and/or oxygen. This is done usually with corrosion protective paintings or coatings.

The selection of those coatings will be based on:

- the maximum/minimum operating service temperature of the underlying metal;
- the corrosivity of the atmosphere where the system is installed;
- the kind of metal to be coated (carbon, low-alloy, austenitic steels).

Guidance on those aspects can be found in the document AGI Q151 “Corrosion protection under insulation”, which complements the ISO 12944 “Paints and varnishes – Corrosion protection of steel structures by protective paint systems” series.

Similar guidance also exists in CINI Manual Part 7.

**ISOVER advice:** *Even if the protective coating of the metal is not part of the insulation contractor’s job, the contractor should check if it has been done properly, and inform the process owner if risks are detected.*

*When installing the insulation and associated supports or spacers if any, the contractor shall avoid damaging the coating.*

*Some of the protective solutions are based on aluminium (Thermal Sprayed Aluminium) or zinc. The contractor shall check that the insulation system (including supports, or tracing elements) is compatible with them (no chemical or galvanic corrosion risks, or abrasion due to differential dilatation values).*

#### 4.3.4 Installation of the insulation system

The insulation system should always be designed and installed in order to minimise the risk of water ingress, and liquid water accumulation.

But depending on the CUI risk analysis (including consideration of the operating temperature, the geometrical constraints), more or less radical solutions will be implemented, such as:

- whether sealing discs should be welded to parts of the object or flashings / rain deflectors should be used as part of the cladding;
- whether water shed cover should be installed above all pipe hangers...

Common best practices can be found in the FESI document N°10 and in the CINI Manual Parts 1, 3 and 4.

*ISOVER advice: Never forget that, in the long term, the absence of water ingress cannot be guaranteed. In such cases, prevention of water accumulation solutions (like drainage plugs and holes) but also maintenance and control shall be planned.*

*Non-metallic cladding material can be considered an option, particularly where there may be complexity of the equipment, an aggressive chemical environment or to avoid galvanic corrosion.*

#### 4.3.5 Maintenance

All insulation systems should be regularly inspected for damage to the cladding and for "points of weakness" that could eventually allow water ingress into the insulation system. The results and dates of these inspections should be recorded.

Damaged cladding on outdoor installations should be rectified immediately to prevent water penetration of the insulation system, which would reduce the insulation's properties and initiate corrosion under the insulation.

Damaged vapour barriers must be sealed as soon as possible or else water vapour will enter the insulation through the damaged area. In areas where the cladding is damaged, the insulation should be removed to allow *inspection of the substrate for corrosion*.

As part of the inspection programme, "high risk" areas for corrosion should have the insulation system removed on a regular basis to detect any possible corrosion under insulation as early as possible to reduce maintenance costs.

Consideration should be given to preparing inspection points that will cause minimum disruption to the cladding and therefore make the resealing of the system more effective.

Another option is to use moisture, water accumulation, or corrosion detection systems. Those early detection systems could help better manage the CUI risk and in the end reduce the inspection costs.



## 5. Industrial Noise Control



1.	Basic concepts.....	164	3.6.	Silencers.....	216
1.1.	Acoustics.....	164	3.6.1.	Definitions .....	216
1.2.	Concept of sound .....	164	3.6.2.	Types of silencers, selection and general principles .....	217
1.3.	Physical properties of sound .....	164	3.6.3.	Absorption silencers .....	217
1.3.1.	Propagation speed .....	164	3.6.4.	Reactive silencers .....	219
1.3.2.	Amplitude.....	164	3.6.5.	Discharge or blow-off silencers.....	219
1.3.3.	Frequency .....	164	3.6.6.	Calculations.....	220
1.4.	Other physical magnitudes .....	165	3.6.7.	Regenerated noise or flow noise .....	222
1.4.1.	Sound intensity.....	165	3.6.8.	Pressure losses.....	223
1.4.2.	Sound power.....	165	3.7.	Vibration control.....	224
1.4.3.	Acoustic impedance.....	165	3.7.1.	Introduction.....	224
1.4.4.	Noise level scale .....	166	3.7.2.	Controlling the natural frequencies ...	225
1.4.5.	Loudness and masking .....	167	3.7.4.	Insulation of vibrations: transmissibility .....	225
1.4.6.	Noise .....	168	3.7.5.	Types of anti-vibration elements .....	227
1.4.7.	Airborne and structure-borne sound ...	168	3.8.	Noise in pipes .....	228
1.4.8.	Transversal and longitudinal waves.....	168	3.9.	Personal protection cabins.....	230
1.4.9.	Weighting scales curve A.....	168	3.10.	Hearing protection .....	232
1.4.10.	Octave band level: third-octave level....	169	3.11.	Active noise control .....	234
1.4.11.	Combination of levels.....	170	3.11.1.	Principles of noise control.....	234
1.4.12.	NR valuation curves.....	170	3.11.2.	What is active noise control?.....	235
1.4.13.	Reflection, absorption and transmission of sound .....	172	3.11.3.	Active noise control systems in ducts.....	236
1.4.14.	Diffraction and refraction. ....	172	3.11.4.	Applications of active noise control systems.....	239
1.4.15.	Vibrations .....	173	4.	Comfort, safety and measurements.....	240
2.	Sound propagation .....	174	4.1.	Comfort and safety aspects of industrial noise.....	240
2.1.	Types of sound sources.....	174	4.2.	Acoustic magnitudes for measurements and verification methods.....	241
2.2.	Sound propagation in open spaces.....	174	4.2.1.	Measuring acoustic variables.....	241
2.2.1.	Point sources .....	174	4.2.2.	Verification methods.....	244
2.2.2.	Line sources.....	176	5.	Examples of noise control.....	246
2.2.3.	Environmental factors .....	177	5.1.	Absorbent treatments .....	246
2.2.4.	Radiation field of a source .....	182	5.2.	Noise control in ducts.....	249
2.3.	Sound propagation in enclosures .....	186	5.3.	Silencers.....	252
2.3.1.	Direct field and reverberated field .....	186	5.4.	Acoustic barriers.....	254
2.3.2.	Absorption coefficients.....	187	5.5.	Acoustic enclosures .....	256
2.3.3.	Reverberation.....	188	5.6.	Noise control in pipes.....	258
2.3.4.	Acoustic conditioning.....	192			
2.3.5.	Sound absorbing materials.....	194			
2.3.6.	Acoustic properties of mineral wool.....	196			
2.3.7.	Acoustic insulation.....	198			
3.	Noise control .....	204			
3.1.	Principles of noise control.....	204			
3.1.1.	Noise control at the source .....	205			
3.1.2.	Noise control in the propagation path .....	207			
3.1.3.	Noise control at the receiver.....	207			
3.2.	Absorbent treatments .....	208			
3.3.	Noise in ducts .....	210			
3.4.	Acoustic enclosures .....	211			
3.5.	Acoustic screens .....	214			

# Industrial Noise Control

## 1. Basic concepts

### 1.1. Acoustics

Acoustics is the science that studies the various aspects related to sound, particularly the phenomena of the generation, propagation and reception of sound waves in various media, as well as its transduction, its perception and its varied technological applications. Acoustics has a strongly multidisciplinary character, covering issues ranging from pure physics to biology and social sciences.

### 1.2. Concept of sound

Sound can be described as a disturbance that propagates through an elastic medium (solid, liquid or gas) at a certain speed that is characteristic of the medium in which it propagates. In the atmosphere, this disturbance is manifested in the form of small periodic fluctuations of pressure above and below the static atmospheric pressure. Once we have seen the physical definition of sound, we can also define sound as the auditory sensation generated by this physical disturbance, and here is the main reason why we need to study these disturbances; the human species, as with many other animal species, has a very developed sense that reacts to these physical disturbances.

### 1.3. Physical properties of sound

The physical properties with which we can characterise the sound are mainly given by the speed of propagation, amplitude and frequency, among other things.

#### 1.3.1. Propagation speed

The speed of sound is the speed at which sound waves propagate in an elastic medium. This speed depends on the mass and elasticity of the medium where they propagate. In the air, sound reaches a speed of 340 m/s at a temperature of 20 °C and 1 atm of pressure.

#### 1.3.2. Amplitude

The amplitude of the sound pressure is defined as the difference at a certain spatial point between the instantaneous pressure and the static atmospheric pressure. This physical value determines a subjective sensation that is associated with a greater or lesser intensity of the sound.

#### 1.3.3. Frequency

The frequency of a sound is the number of fluctuations per second of the air pressure expressed in hertz [Hz]. This physical value determines a subjective sensation that is associated with a low or high tone. The lower the frequency, the lower the sound will appear, and the higher this frequency, the higher the sound will appear to us. There is another way of characterising this physical magnitude, and it is through the period of sound  $T$ . This value is the inverse of the frequency  $f = 1/T$ , meaning that the higher the frequency, the shorter the period, while the lower the frequency, the higher the period. The relation is between the frequency of the wave  $f$  and its speed of propagation  $c$ :

$$c = \lambda f \quad c = \lambda / T$$

= the wave or space travelled by the wave in a complete cycle.

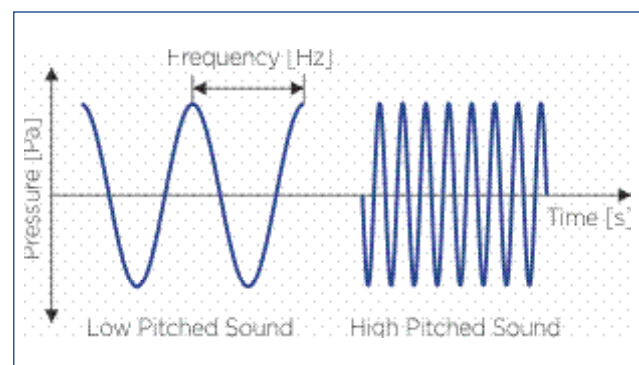

## 1.4. Other physical magnitudes

It is important to know other physical magnitudes related to sound, such as sound intensity, sound pressure, acoustic impedance and other parameters or magnitudes of daily use.

### 1.4.1. Sound intensity

As we have seen, the two fundamental sensations that the ear gives us are frequency and intensity. Intensity is a magnitude that is partly subjective. It is related to sound pressure, which can be measured objectively; however, two sounds of equal sound pressure and different frequency do not produce the same sensation of intensity. It is defined as energy per area unit and is measured in  $W/m^2$ . For the ear to start perceiving a sound, the acoustic pressure must be at least 20 QPa. This is what is called the auditory threshold. In the scale of intensities, the auditory threshold is 10 to 12  $W/m^2$  and the painful threshold is 25  $W/m^2$ . To see how our ear perceives sound, we refer to the Weber-Fechner law: "Our sound impressions vary according to an arithmetic progression, while the physical excitations that cause them vary according to a geometric progression". That is, if the excitation varies from 10 to 100, our sound impression varies from 1 to 2. To simplify the calculations, and for what was said in the previous paragraph, we use a mathematical process where we represent the acoustic measurements in a logarithmic scale. The sound level produced by a sound pressure  $P$  is measured using the formula:

$$L_p = 20 \log \frac{P}{P_0}$$

$P$  = sound pressure produced, [Pa]

$P_0$  = 20 QPa, sound pressure of auditory threshold

$L_p$  = sound pressure level, [dB]

It is observed that the dB unit is dimensionless and has no physical sense. On the other hand, since the sound intensities are proportional to the square of the pressures, the above formula can be written:

$$L_I = 10 \log \frac{I}{I_0}$$

$I$  = sound intensity produced, [ $W/m^2$ ]

$I_0$  = 10 (to 12)  $W/m^2$  is the sound intensity of the auditory threshold

$L_I$  = sound intensity level, [dB]

### 1.4.2. Sound power

The sound power of a source is expressed in watts. It is more convenient to express the sound power in a logarithmic scale, and it would, therefore, give us the level of sound power. The sound power level of a source is expressed by the following:

$$L_w = 10 \log \frac{W}{W_0}$$

$W$  = sound power source, [W]

$W_0$  = 10 to 12 W is the reference power in watts

$L_w$  = sound power level, [dB]

### 1.4.3. Acoustic impedance

Each medium - solid, liquid or gaseous - offers a more or less large facility for the propagation of sound. Similar to electric current, it is said that the medium has an acoustic impedance ( $Z$ ). Impedance is defined as the quotient between the acoustic pressure ( $P$ ) and the velocity of the vibratory movement, which is defined above as the velocity of sound ( $v$ ). That is to say:

$$Z = P/v$$

and for the case of flat waves, it can also be expressed by:

$$Z = \rho c$$

where  $\rho$  is the volumetric mass (density) and  $c$  is the velocity of propagation. It is measured in acoustic Ohms,  $g/(s \cdot cm^2)$ , or in Rayls,  $(Pa \cdot s)/m$ .

#### 1.4.4. Noise level scale

Sound sources of high volume respectively in large numbers frequently generate sound that is in the danger area of the human ear ( $L_r > 80$  to  $85$  dB(A)).

The limit values of the human hearing range are at about  $0.00001$  Pa and  $100$  Pa ( $10$  QPa and  $100$  Pa), thus extending over  $10^7$  in the pressure range. The sensation of hearing does not increase with the sound pressure, but with the sound intensity, which in turn is proportionate to the second power of the sound pressure. If one decided to describe a sound occurrence in a way adjusted to the human ear with the help of the most readily available measuring value, this would lead to a scale embracing  $10^{14}$ , a very ungainly procedure for practical purposes. A different procedure, which is also used in other engineering areas, reduces this

vast area of figures quite considerably: one divides the value just sought ( $P^2$  through the reference value at the lower end of the scale  $P^2_0$  and finds the tenth logarithm of this reference value) (see 1.4.1). Such logarithmic energy relations are identified with the letters Bel (after Alexander Graham Bell, the inventor of the electro-magnetic telephone). The compression of the range thus achieved from  $10^{14}$  to a scale between  $0$  and  $14$  Bel, however, means too rough a scale for practical application. Therefore, the tenth part of the unit Bel, the decibel (dB), has been chosen as the measuring value and the logarithmic energy relations obtained through the procedure described are called level  $L$ . The decibel (symbol: dB) is a logarithmic unit used to express the ratio of one value of a physical property to another, and may be used to express a change in value or an absolute value.

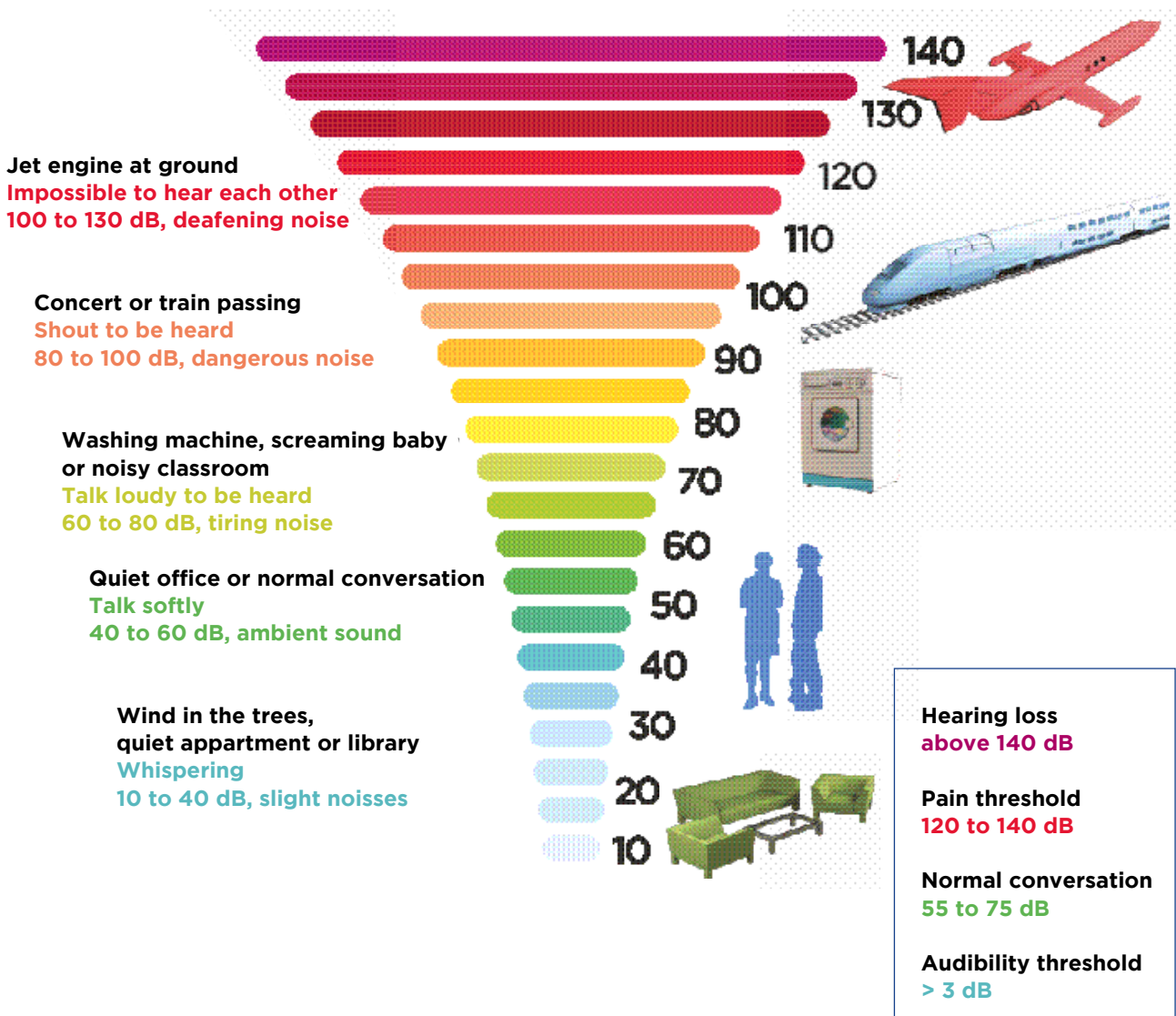

### Human audible range: from 20 Hz to 20,000 Hz

The range of hearing of a young, healthy human being ranges from 16 Hz (lower audibility limit) up to 20,000 Hz (upper audibility limit; for 60-year-old 5,000 Hz); this embraces 10 octaves. The ranges of importance for us are the range for building acoustics from 50 Hz to 5,000 Hz and the range for technical acoustics from 25 Hz to 10,000 Hz. The audible range is limited for low sound pressures through audibility and to high sound pressures through pain. The sensitivity of the human ear at the threshold of audibility is just beyond the recognisability of one's own organic sound (heartbeat, breathing).

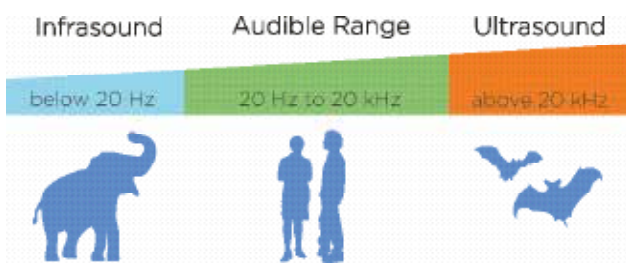

Below the human audible range is the infrasound area. As in application practice, infrasound is used in bearing vibrations, structure-borne sound, building vibration analysis, earthquake waves, etc. Above the human audible range is the ultrasound area. As in application practice, ultrasound is used in cleaning, degassing, dispersing, emulsifying, polymerisation control, ultrasonic sound treatment (drilling, cutting), damage-free material testing ultrasonic diagnostics (pregnancy), urinary calculus pulverisation, model acoustics theft protection, etc.

### 1.4.5. Loudness and masking

The human ear is not equally sensitive to all frequencies. Fletcher and Munson studied the variation of ear sensitivity with sound pressure (the acoustic level) and summarised their study in curves that show this variation of sensitivity as a function of frequency.

As we can see, sensitivity is maximum for 1 kHz, it is somewhat lower for higher frequencies, and it decreases a lot for low frequencies. This effect of sensitivity depends on the person and age; hearing acuity decreases with age for frequencies above 5 kHz.

The sensitivity of the human ear to pure tones is not the same in the case of sounds and noise consisting of various tones. This is what is known as the "masking effect". This phenomenon is very important in everyday life, and its effect can be advantageous or disturbing. For example, in a house, you can sometimes not hear the noise of the neighbours' conversation or radio, and it is not because the walls or floor slabs reduce the noise to below the auditory threshold, but that there is a "masking" noise, which can be traffic noise or some activity in the house. When these "background noises" disappear, such as at night, the disturbing noises that were previously inaudible are perceived.

### 1.4.6. Noise

Noise is an inarticulate or confusing sound that often causes an unpleasant auditory sensation. Because of its physiological effects, noise can be a source of discomfort. The sudden appearance of an unusual noise brings about a modification of the physiological activity - increase in heart rate, modification of breathing rate, variation of arterial pressure, ... Unfortunately, the disturbance of a noise that should be considered as annoying is not only influenced by the physiological laws of sound sensitivity, but also by the psychological, subjective and very variable disposition with time of each particular observer.

**1.4.7. Airborne and structure-borne sound**

Vibrations of solid, liquid or gaseous media, which are caused by forces changing over time, or by accelerating movements, are called sound. Dependent upon the character of the medium, one discerns between airborne, structure-borne and waterborne sound.

**Structure-borne sound** describes sound vibrations in solid bodies. Longitudinal and bending waves, transverse, torsion, quasi-longitudinal and Rayleigh waves (surface waves) exist. In building acoustics and technical acoustics, structure-borne sound has great importance for the airborne sound as a cause and an intermediate stage.

**Airborne sound** describes sound vibrations in air that are longitudinal waves.

**1.4.8. Transverse and longitudinal waves**

Longitudinal waves are waves in which the displacement of the medium is in the same direction as, or the opposite direction to, the direction of propagation of the wave. Mechanical longitudinal waves are also called compressional or compression waves, because they produce compression and rarefaction when travelling through a medium, and pressure waves, because they produce increases and decreases in pressure. The other main type of wave is the transverse wave, in which the displacements of the medium are at right angles to the direction of propagation. Some transverse waves are mechanical, meaning that the wave needs a medium to travel through. Transverse mechanical waves are also called "shear waves".

**1.4.9. Weighting scales curve A**

The weighting scales allow us to estimate the ear's behaviour according to the characteristics of the noise to which it is exposed, since it can attenuate or amplify it depending on the level of sound pressure and its frequency spectrum. The curves of equal loudness of Fletcher and Munson estimate the corresponding relationship between frequency and intensity (in dB), so that any point of the curve has the same sound sensation. Below is an example of their interpretation, where a sound pressure level of 30 dB at 1,000 Hz is equivalent to 50 dB at a frequency of 60 Hz.

Fletcher-Munson equal loudness curve

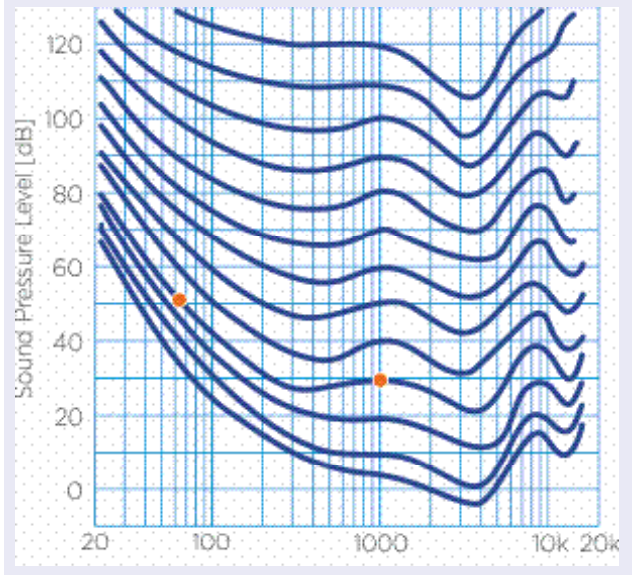

From the equal loudness curves, the weighting scales "A" and "C" were established, which are used to approximate the response of the measuring instruments to the attenuation or amplification characteristics of the human ear at different sound pressure levels. The rule establishes that it applies:

- The weighting scale "A" for the equivalent, continuous sound pressure level.
- The weight scale "C" for the peak level.

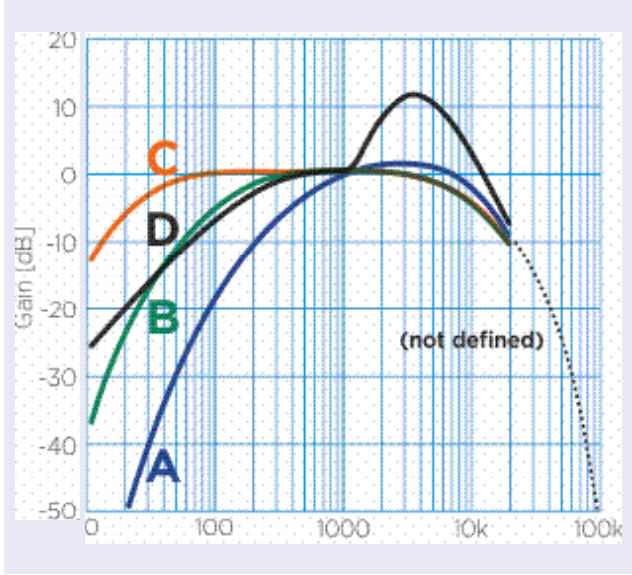

**1.4.10. Octave band level: third-octave level**

To know a noise, its distribution in frequencies is important. Normally the audible frequency range is divided into bands with a width of one octave. An octave band is a frequency interval between two sounds whose frequency ratio is 2 (e.g. from 707 Hz to 1414 Hz).

The octave centre frequencies have been standardised by international agreement. When it is necessary to know more details about the analysis of the octave bands, a third-octave band analysis is used, which involves dividing each octave band into three intervals. An octave is a collection of frequencies (1/1, 1/3, 1/12, 1/24).

Octave				Third-octave			
f <sub>1</sub>	f <sub>m</sub>	f <sub>2</sub>	A curve	f <sub>1</sub>	f <sub>m</sub>	f <sub>2</sub>	A curve
Hz	Hz	Hz	dB	Hz	Hz	Hz	dB
11	<b>16</b>	22	-56.7	11.0 14.1 17.8	<b>12.5</b> <b>16.0</b> <b>20.0</b>	14.0 17.8 22.4	-63.4 -56.7 -50.5
22	<b>31.5</b>	44	-39.4	22.4 28.2 35.5	<b>25.0</b> <b>31.5</b> <b>40.0</b>	28.2 35.5 44.7	-44.7 -39.4 -34.6
44	<b>63</b>	88	-26.2	44.7 56.2 70.7	<b>50.0</b> <b>63.0</b> <b>80.0</b>	56.2 70.7 89.1	-30.2 -26.2 -22.5
88	<b>125</b>	177	-16.1	89.1 112.0 141.0	<b>100.0</b> <b>125.0</b> <b>160.0</b>	112.0 141.0 178.0	-19.1 -16.1 -13.4
177	<b>250</b>	355	-8.6	178.0 224.0 282.0	<b>200.0</b> <b>250.0</b> <b>315.0</b>	224.0 282.0 355.0	-10.9 -8.6 -6.6
355	<b>500</b>	710	-3.2	355.0 447.0 562.0	<b>400.0</b> <b>500.0</b> <b>630.0</b>	447.0 562.0 708.0	-4.8 -3.2 -1.9
710	<b>1,000</b>	1,420	0	708.0 891.0 1,122.0	<b>800.0</b> <b>1,000.0</b> <b>1,250.0</b>	891.0 1,122.0 1,413.0	-0.8 0 +0.6
1,420	<b>2,000</b>	2,840	+1.2	1,413.0 1,778.0 2,239.0	<b>1,600.0</b> <b>2,000.0</b> <b>2,500.0</b>	1,778.0 2,239.0 2,818.0	+1.0 +1.2 +1.3
2,840	<b>4,000</b>	5,680	+1.0	2,818.0 3,548.0 4,467.0	<b>3,150.0</b> <b>4,000.0</b> <b>5,000.0</b>	3,548.0 4,467.0 5,623.0	+1.2 +1.0 +0.5
5,680	<b>8,000</b>	11,360	-1.1	5,623.0 7,079.0 8,913.0	<b>6,300.0</b> <b>8,000.0</b> <b>10,000.0</b>	7,079.0 8,913.0 11,220.0	-0.1 -1.1 -2.5
11,360	<b>16,000</b>	22,720	-6.6	11,220.0 14,130.0 17,780.0	<b>12,500.0</b> <b>16,000.0</b> <b>20,000.0</b>	14,130.0 17,780.0 22,390.0	-4.3 -6.6 -9.3

### 1.4.11. Combination of levels

It is often necessary to combine levels, such as for calculating the sound level resulting from several sound sources, and take into account that the sum of levels is not the sum of the individual levels, but it is a logarithmic sum. The general formula for adding decibels is:

$$dB_T = 10 \log \sum 10^{\frac{dB_i}{10}}$$

There are graphs to combine sound levels that easy to apply, as the one shown below.

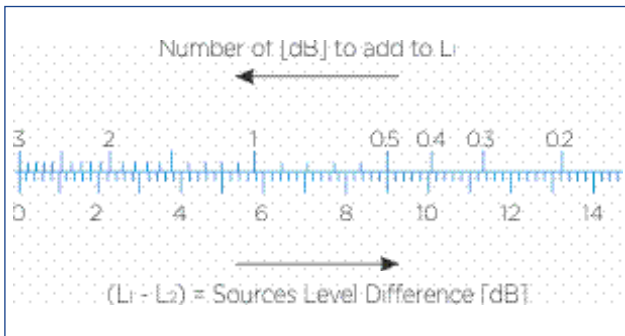

Example:

Sum of L<sub>1</sub> = 87 dB and L<sub>2</sub> = 80 dB. The right side of the graph searches for L<sub>1</sub> - L<sub>2</sub> = 7 dB, and A = 0.8 dB is determined for adding to L<sub>1</sub> (the highest level), giving L<sub>1</sub> + L<sub>2</sub> = 87.8 dB.

### 1.4.12. NR valuation curves

In Europe, NR curves (noise rating curves) are used to classify noise levels. These curves make it possible to assign a single NR number (ISO R-1996) to the spectrum in frequencies of a noise, measured in octave bands, and which corresponds to the curve that remains above the said noise level values in each band.

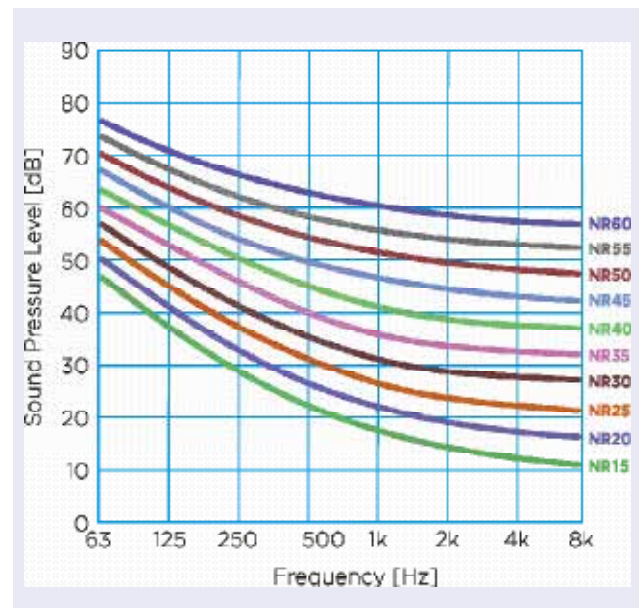

NR	Sound pressure levels in octave bands (dB)								
	Central frequencies (Hz)								
	31.5	63	125	250	500	1,000	2,000	4,000	8,000
0	55.4	35.5	22.0	12.0	4.8	0.0	-3.5	-6.1	-8.0
5	58.8	39.4	26.3	16.6	9.7	5.0	1.6	-1.0	-2.8
10	62.2	43.4	30.7	21.3	14.5	10.0	6.6	4.2	2.3
15	65.6	47.3	35.0	25.9	19.4	15.0	11.7	9.3	7.4
20	69.0	51.3	39.4	30.6	24.3	20.0	16.8	14.4	12.6
25	72.4	55.2	43.7	35.2	29.2	25.0	21.9	19.5	17.7
30	75.8	59.2	48.1	39.9	34.0	30.0	26.9	24.7	22.9
35	79.2	63.1	52.4	44.5	38.9	35.0	32.0	29.8	28.0
40	82.6	67.1	56.8	49.2	43.8	40.0	37.1	34.9	33.2
45	86.0	71.0	61.1	53.6	48.6	45.0	42.2	40.0	38.3
50	92.9	75.0	65.5	58.5	53.5	50.0	47.2	45.2	43.5
55	89.4	78.9	69.8	63.1	58.4	55.0	52.3	50.3	48.6
60	96.6	82.9	74.2	67.8	63.2	60.0	57.4	55.4	53.8
65	99.7	86.8	78.5	72.4	68.1	65.0	62.5	60.5	58.9
70	103.1	90.8	82.9	77.1	73.0	70.0	67.5	65.7	64.1
75	106.5	94.7	87.2	81.7	77.9	75.0	72.6	70.8	69.2
80	109.9	98.7	91.6	86.4	82.7	80.0	77.7	75.9	74.4
85	113.3	102.6	95.9	91.0	87.6	85.0	82.8	81.0	79.5
90	116.7	106.6	100.3	95.7	92.5	90.0	87.8	86.2	84.7
95	120.1	110.5	104.6	100.3	97.3	95.0	92.9	91.3	89.8
100	123.5	114.5	109.0	105.0	102.2	100.0	98.0	96.4	95.0
105	126.9	118.4	113.3	109.6	107.1	105.0	103.1	101.5	100.1
110	130.3	122.4	117.7	114.3	111.9	110.0	108.1	106.7	105.3
115	133.7	126.3	122.0	118.9	116.8	115.0	113.2	111.8	110.4
120	137.1	130.3	126.4	123.6	121.7	120.0	118.3	116.9	115.6
125	140.5	134.2	130.7	128.2	126.6	125.0	123.4	122.0	120.7
130	143.9	138.2	135.1	132.9	131.4	130.0	128.4	127.2	125.9

### 1.4.13. Reflection, absorption and transmission of sound

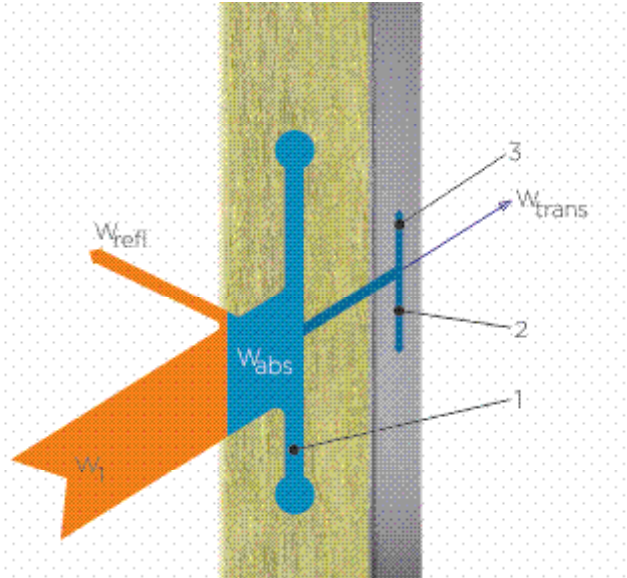

- $W_1$  = incident acoustic energy
- $W_{refl}$  = reflected acoustic energy
- $W_{abs}$  = absorbed acoustic energy
- 1 = acoustic absorption of the material
- 2 = attenuation of the sound transmitted by the structure (dissipation - heat transformation)
- 3 = decline with distance
- $W_{trans}$  = transmitted acoustic energy

When a sound wave hits a boundary surface, part of the incident energy is reflected, part is absorbed and part is transmitted to the other side of this surface, which results in the reflection, absorption and transmission of sound.

### 1.4.14. Diffraction and refraction

There are other phenomena in the propagation of sound waves that are important to know, such as diffraction, refraction and diffusion.

**Diffraction:** when a wave hits an opening or an obstacle that prevents its propagation, all points of its plane become secondary sources of waves, emitting new waves that are called diffracted waves. This phenomenon is based on the Huygens principle.

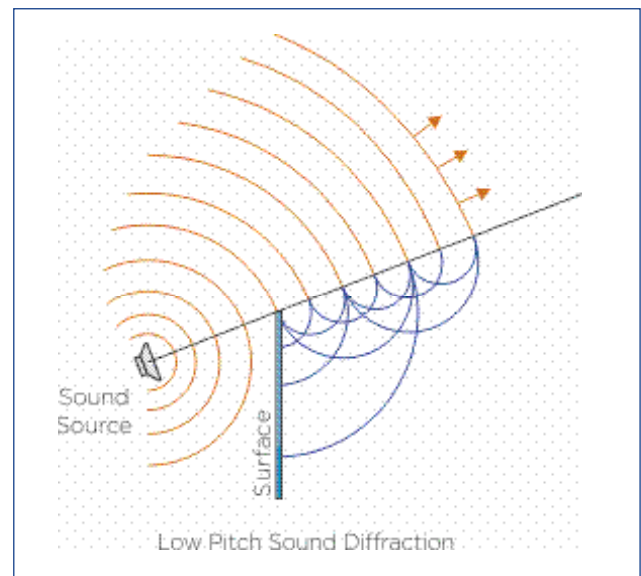
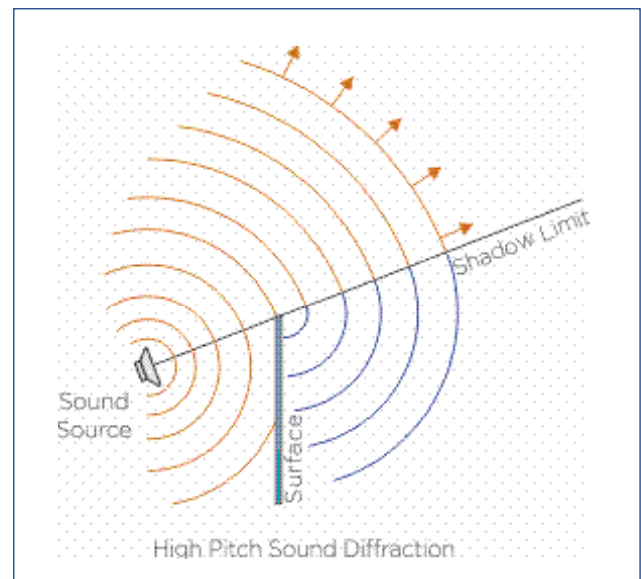

**Refraction:** is the phenomenon that occurs when a sound wave passes from one medium to another, changing its direction and is produced by the variation of the sound wave's speed between one medium and another.

#### 1.4.15. Vibrations

The sensation of vibration is generally understood as the sensation of vibrating excitation that is produced by direct contact of the human body with a solid, vibrating body. As there is no specific organ that perceives this type of vibration, it is not possible to make a clear separation between sound and vibration sensation, unless we limit the expression of vibration to vibrations below 16 Hz (or 20 Hz); that is, infrasound that cannot be perceived as sound. However, this limitation is not reasonable, either physically or physiologically, since the ear can perceive the sounds that reach and excite the eardrum, as well as the vibrations of the skull bones that directly excite the inner ear (hearing by bone conduction, hearing aids). The sensory cells of the skin can also feel the vibrations and, when these are strong, they can cover the whole body and extend this sensation to the internal organs, mainly to the lungs and stomach, since the air pockets that contain these organs act as amplifiers of vibrations.



## 2. Sound propagation

### 2.1. Types of sound sources

The different types of sound sources are defined according to the way the energy is propagated to the environment. The first case we can consider is the sound source whose wave front propagates in all possible directions in the same way. This is the case of a point source whose propagation can be spherical if the source is suspended in space, or hemispherical if it is supported on a reflective surface or in a quarter sphere if the source is resting on two reflecting surfaces. In most real cases, sound sources must approach this type of point source.

When the sound source has larger magnitudes in one dimension than in the rest, we call this a linear source. Its wave front will not propagate spherically, but cylindrically to the environment.

Let's see how we can parametrise this type of source. Let's take, for example, a street with road traffic. In a first approximation, this source of sound can be modelled as  $n$  sources separated by a distance  $b$ . Obviously, this is not a very realistic approach, but it allows us to start studying the problem. We can call this type of source a Discrete Online Sources. Within this type of source, we can consider those whose number of sources is finite, and those whose number of sources is infinite.

The second type of line source that we can consider is one that has finite dimensions but an infinite number of sound sources. With this type of source, we can parametrise the traffic of a railroad or that of a motorway during rush hour.

### 2.2. Sound propagation in open spaces

In this section, we will study the propagation in open spaces of the sound generated by the different sources mentioned in the previous section. For this, we will study the propagation of sound in a homogeneous medium and then study what happens in real propagation in open spaces.

#### 2.2.1. Point sources

If we consider a homogeneous propagation medium without absorption, the wave front of a power point source of sound  $W$  is a spherical front, whereby the intensity of the wave will decrease with the square of the distance according to the equation:

$$|I| = \frac{W}{4\pi r^2}$$

where we can obtain the relationship of the intensities at two distances  $r_1$  and  $r_2$ .

$$\frac{|I_1|}{|I_2|} = \frac{r_2^2}{r_1^2}$$

If we transform it into pressure levels, we will obtain that the loss of energy by geometric divergence of a point source is given by:

$$L_1 - L_2 = 10 \log \frac{I_1}{I_2} = 10 \log \frac{r_2^2}{r_1^2} = 20 \log \frac{r_2}{r_1}$$

where, considering  $r_1 = 2r_2$ , we obtain the relation:

$$L_1 - L_2 = 6 \text{ dB}$$

It is verified that when doubling the distance, the sound pressure level drops by 6 dB. It is verified with the previous expressions that in the case of an omnidirectional and point sound source in a free field without obstacles, the sound pressure level depends on the distance from the source.

The sound pressure level of a point source can generally be expressed as follows:

$$L_p = L_w - 20 \log(r) - 10 \log(4\pi / Q)$$

$L_w$  being the power level of the source,  $Q$  the directivity factor of the source (see 2.2.4), and  $r$  the distance from the centre of the sound source.

When this omnidirectional point source is far from any reflective plane, the sound energy propagates as spherical waves, and all points located at the same distance from the sound source have the same sound level. For spherical propagation, the directivity factor is 1, so the previous expression remains as:

$$L_p = L_w - 20 \log(r) - 11 \text{ dB}$$

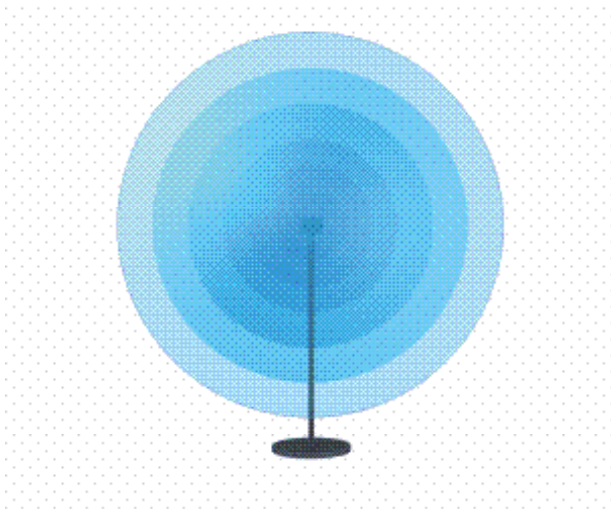

**Sound level of a point source near a reflective plane**

When a point source is close to the ground, the sound energy extends over a hemisphere due to the reflections from the ground. As a result, the sound intensity doubles at a given distance compared to the distribution in an entire sphere. In this case, the directivity factor  $Q$  is 2 and the sound pressure level is determined by the equation:

$$L_p = L_w - 20 \log(r) - 8 \text{ dB}$$

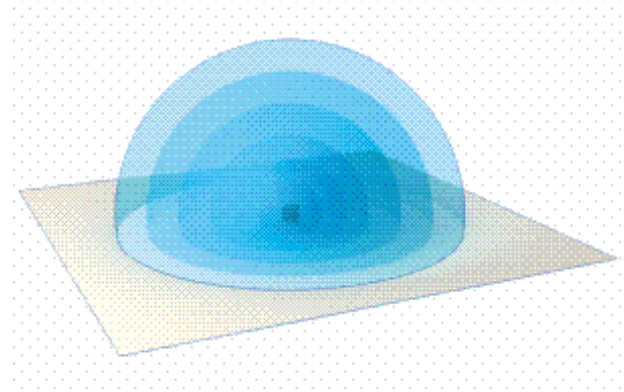

**Sound level of a point source near two reflective planes**

When a point source is near the ground and near a wall, the sound energy extends over a quarter sphere due to the reflections from the two surfaces. As a result, the sound intensity doubles at a given distance compared to the distribution in a hemisphere. The directivity factor  $Q$  is 4 and the sound pressure level is determined by the equation:

$$L_p = L_w - 20 \log(r) - 5 \text{ dB}$$

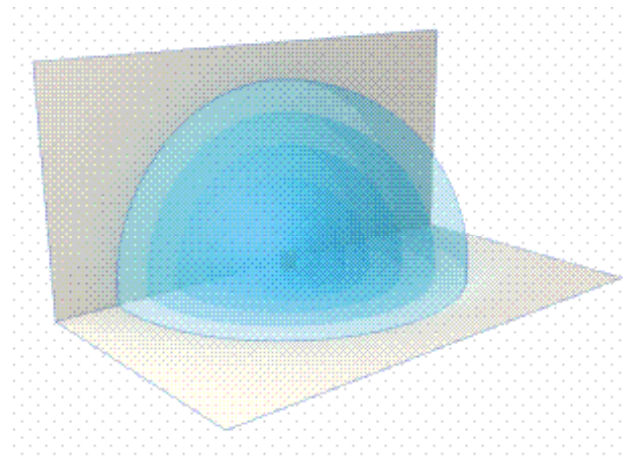

### 2.2.2. Line sources

#### Infinite line sources

For a line source emitting in a homogeneous medium without absorption, the wave front is not spherical, but cylindrical, with which the intensity of the wave will decrease following the ratio:

$$|I| = \frac{W}{4\pi r}$$

If we repeat the procedure performed with the point sources, we will obtain that the loss of energy by geometric divergence if a line source is given by the equation:

$$L_1 - L_2 = 10 \log \frac{r_2}{r_1}$$

where, considering  $r_1 = 2r_2$ , we obtain the relation:

$$L_1 - L_2 = 3 \text{ dB}$$

#### Finite line sources

Assuming a finite line source at a distance of  $r_0$  and a length of  $d$

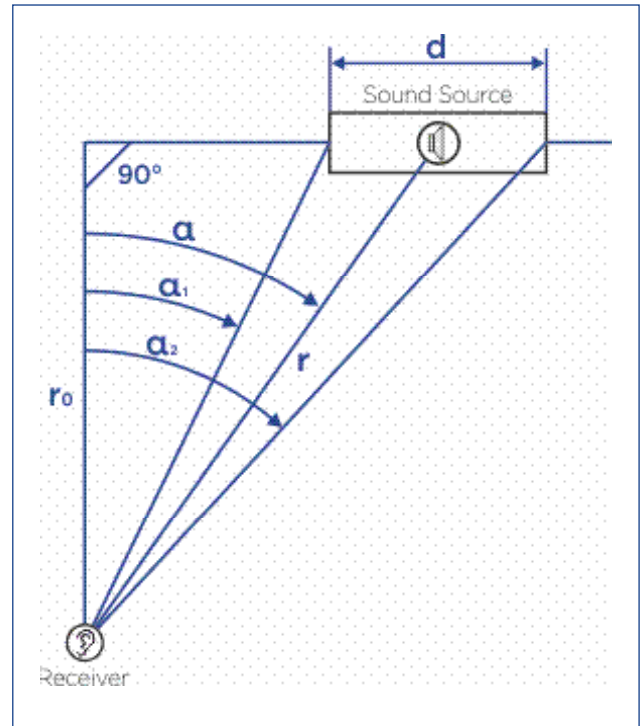

In this case, the sound pressure level is determined by:

$$L_p = L_{WL} + 10 \log \left( \frac{\alpha_2 - \alpha_1}{r_0 d} \right) - 8$$

$L_{WL}$  = sound power per unit of length

$\alpha_1$  = angle from the start of the source

$\alpha_2$  = angle from the end of the source

**2.2.3. Environmental factors**

Previously, we assumed a homogeneous medium without absorption, but the propagation of sound in the atmosphere evidently involves the loss of energy in the form of heat, and the pressure is exponentially reduced during propagation. For a spherical wave, this decrease can be quantified as

$$\Delta L = 20 \log e^{-\alpha_a(r_1-r_2)}$$

$\alpha_a$  = a constant that characterises the attenuation of the propagation medium

If we apply logarithms, we obtain

$$\Delta L = 8.7 \alpha_a (r_1 - r_2)$$

From here, we can obtain that  $8.7 \alpha_a$  are the decibels lost per metre travelled due to absorption of the medium.

**Temperature and humidity influence**

In the case of air, the parameters that influence absorption are its temperature and humidity. Atmospheric attenuation at 20 °C can be calculated as

$$\Delta L = 7.4 \frac{f^2 r}{\phi} 10^{-9}$$

- f = frequency of the band, [Hz]
- $\phi$  = relative humidity, [%]
- r = distance between the source and the observer in metres

For other temperatures, the approximation used for the calculation of the attenuation is given by

$$\Delta L(T, \phi = 50\%) = \frac{\Delta L(20^\circ C, \phi = 50\%)}{1 + \beta f \Delta T}$$

- T = difference in temperature with respect to the reference temperature of 20 °C
- $\beta$  = a constant of value  $4 \cdot 10^{-6}$  for T, [°C]

**Temperature gradient influence**

The speed of sound in the air, or that which is the same as the speed with which the disturbances propagate, depends on the atmospheric pressure  $P_0$  and the density  $\rho_0$  of the air according to the formula of Laplace.

$$c = \sqrt{\frac{1.4 p_0}{\rho_0}}$$

The density  $\rho_0$  of the air is a function of the temperature of the air, so at 22 °C and a pressure of 10 Pa (ffi 1 atm), the parameter  $\rho_0$  has a value of 1.18 kg/m<sup>3</sup> and the speed of sound is 345 m/s. At the usual ambient temperatures, we can assume that approximately

$$c = 331.4 + 0.607 \phi \text{ m/seg}$$

$\phi$  = temperature, [°C]

The real atmosphere is not a uniform medium, so the temperature is variable at each point of the medium. Although more complex situations are possible, we will simplify the study to two cases where there is a unique relationship between temperature and height. Let's take a first case in which the temperature decreases with height; this is the usual behaviour of the atmosphere, which we will call a situation with negative gradient. In the second case, the temperature increases with height, a behaviour known as thermal inversion or a positive gradient.

To understand what happens in these cases, let's take a homogeneous atmosphere in all directions; the temperature will be the same in any direction and, consequently, the speed of sound too. This causes spherical wave fronts and the sound ray perpendicular to the wave front will be straight lines that leave the source. With this the wave front reaches the equidistant points of the source at the same time instant, having travelled this wave front the same distance in all the equidistant points, and having lost the same energy in all of them.

If, on the other hand, the temperature is not constant, the speed of the sound will not be either, there being privileged directions where the speed will be higher than in others. This fact causes the wave front to deform and the sound rays (perpendicular to the wave front) to curve and stop being straight lines.

This means that the wave front travels a greater distance to reach some points than others, even though all these points are equidistant from the source. This can cause so-called shadow areas where the sound level is lower than at other points equidistant from the source.

In the case of a negative gradient

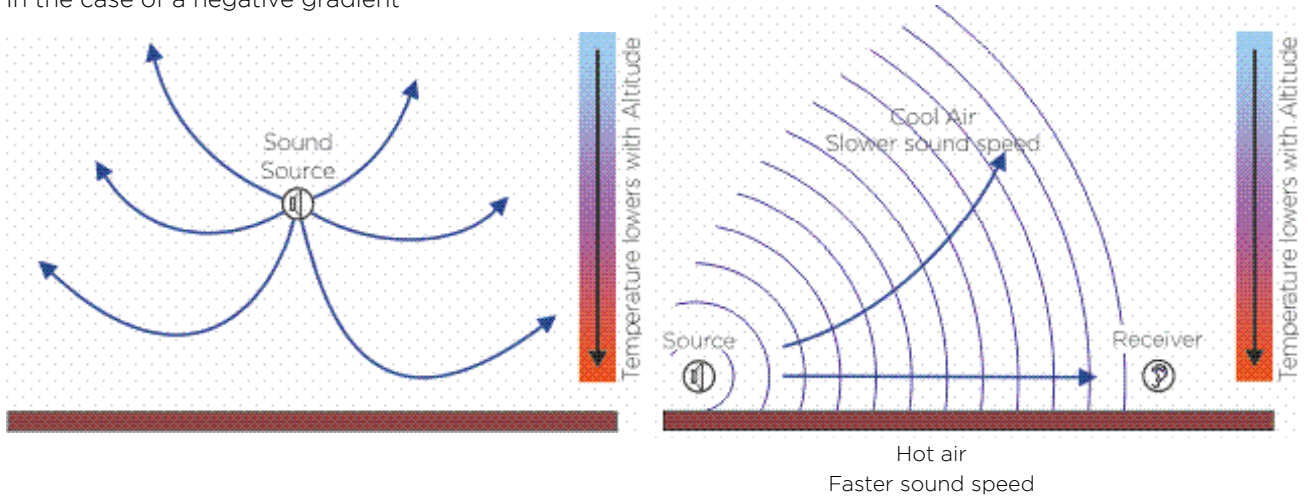

In the case of thermal inversion, the sound rays take the following form:

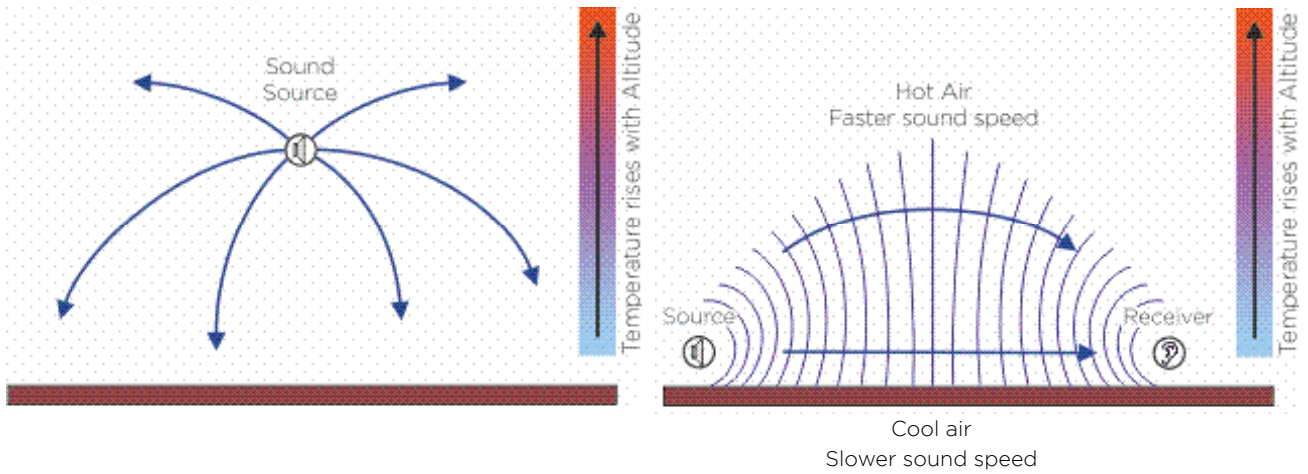

**Influence of wind**

The behaviour of wind in the atmosphere is as variable as the behaviour of temperature, so that, although it is theoretically possible to study it, we need to start from grand simplifications. The influence of wind on propagation has the same origin as the influence of temperature. The presence of a wind gradient modifies the speed of sound in each of the directions of propagation, as would happen when the temperature modifies the trajectory of the sound rays.

If we assume that wind speed increases with height, the curvature of the sound rays causes a shadow zone to be generated on the side where the wind blows. This is why it is difficult for us to listen to a source when the wind is blowing in the opposite direction to the sound propagation.

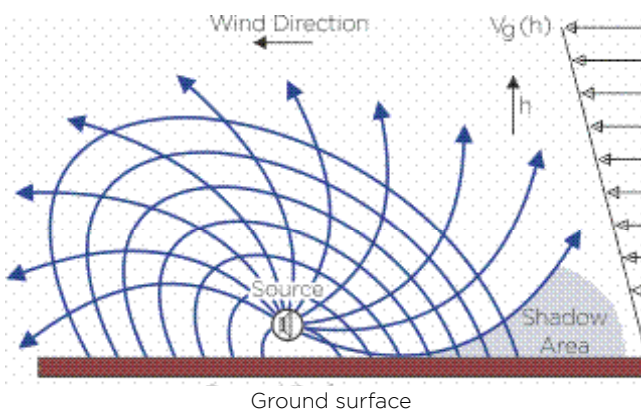
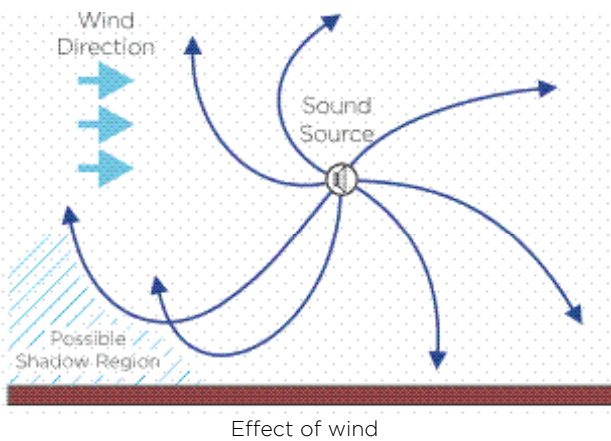

### Influence of the soil

Absorption due to the soil is a function of the structure and its acoustic characteristics thereof. Although it is extremely complicated to theoretically study the behaviour of the soil in the propagation of sound, in a first approximation, we can suppose that its influence is negligible at short distances (between 30 to 70 m), while at greater distances, (70 to 700 m) the attenuation can be expressed in terms of dB/100 m as long as the total attenuation does not exceed 30 dB.

There are semi-empirical laws that try to simulate the propagation in different types of soil, although their approximate values can give us an idea of the order of magnitude of this absorption.

$$\Delta L_{\text{terrain}} = (0.18 \log f - 0.31)r$$

$$\Delta L_{\text{soil}} = 0.01 f^{1/4} r$$

f = frequency of sound in Hz  
r = path of ground

There are tables that indicate the attenuation depending on the type of soil.

### Propagation near the ground

When the path of propagation is close to the ground, there are factors that increase the absorption with respect to that which occurs in the higher path. This extra-attenuation zone comprises a few centimetres to several metres. In this strip, the movements of terrestrial objects, the vegetation and natural barriers near the ground increase the attenuation.

### Influence of barriers

The placement of non-porous walls of a sufficient density (minimum of 20 kg/m<sup>2</sup>) can generate considerable energy losses in the path of propagation between the source and an observer. However, we will return to this subject in more detail in specific applications in later chapters, where we will introduce some concepts.

The analysis of this influence is carried out analytically based on experimental results and the consistency of these data with the Fresnel optical diffraction theory. This analysis is carried out separately for point and line sources (Maekawa study) (see Chapter 3.5).

For point sources, the attenuation produced by a barrier is given by:

$$\Delta L = 20 \log \frac{\sqrt{2\pi N}}{\tanh \sqrt{2\pi N}} + 5 \quad N \geq -0.2$$

$$\Delta L = 0 \quad N < -0.2$$

N = Fresnel number

$$N = \pm \frac{2}{\lambda} (A + B - d)$$

= wavelength of the sound  
d = straight path between source and observer  
A + B = path travelled by saving the barrier between source and observer, + if the observer is in the shadow zone and - if the observer is in the area of light

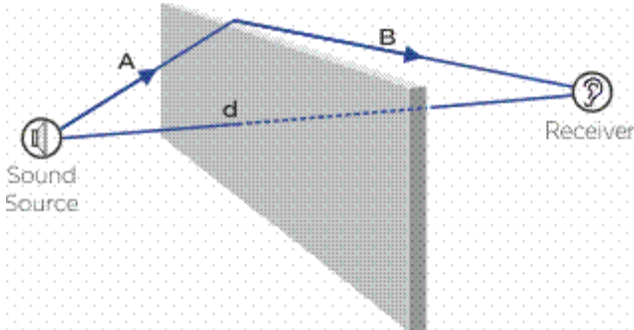

In the light area  $N < -0.2$ , the attenuation can be assumed as negligible, while in the transition zone to the shadow zone, the attenuation can be assumed to be from 0 to 5 dB.

In the shadow zone, the attenuation can oscillate in a range of values between 5 dB and 24 dB. This practical limit is the result of a large number of experiments.

For line sound sources parallel to the axis of the barrier, the attenuation can be calculated with the same equation, but substituting  $N$  with  $N_{max}$ , where:

$$N_{max} = \pm \frac{2}{\lambda} (A + B - d)$$

$d$  = distance between source and observer in the projection plane that is perpendicular to the barrier

$A + B$  = path travelled between source and observer in this propagation plane that is perpendicular to the barrier

If the source and observer are close to the barrier, we need to increase the attenuation with a term:

$$10 \log \left( \frac{A + B}{d} \right)$$

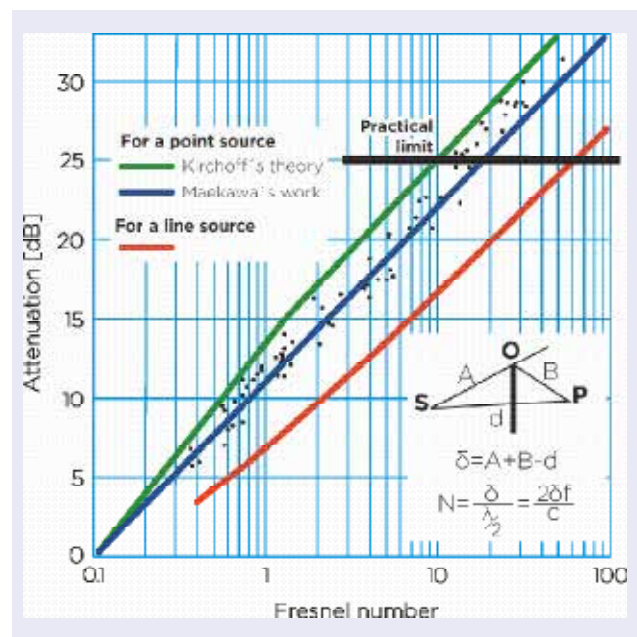
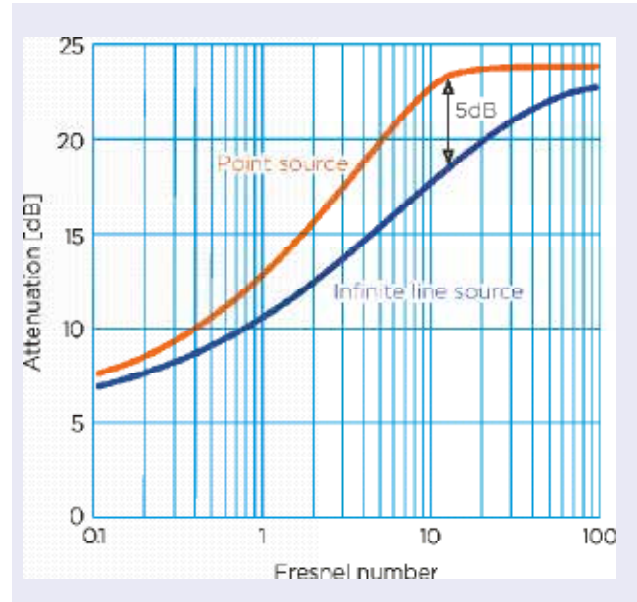

### 2.2.4. Radiation field of a source

#### Near field and far field

The characteristics of the radiation field of a sound source depend on the distance from the source. In the vicinity of the sound source, the velocity of the particles of the medium does not necessarily have to be in the direction of wave propagation, with which a tangential velocity component appears at each point of the space. We will call this area a near field and it is characterised by an appreciable variation of sound pressure levels along a sphere surrounding the source.

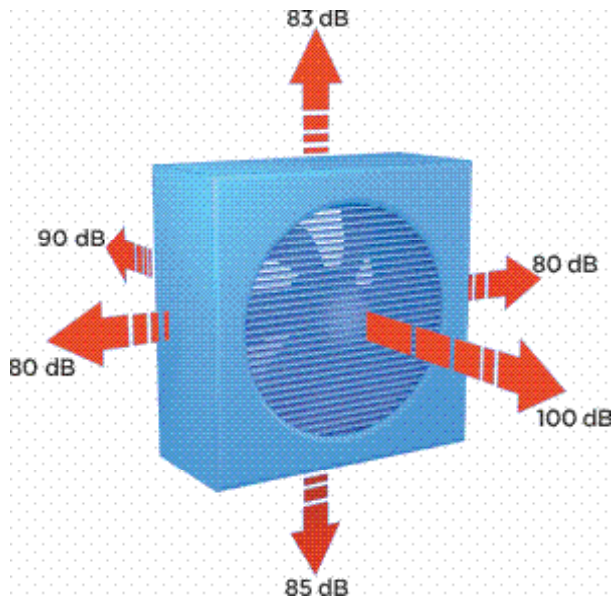

The extension of this near field is a function of the frequency and the dimensions of the source. Theoretically, it is difficult to delimit the near field; an experimental exploration for this is required.

In what we will call the far field, the sound pressure level of a point source decreases 6 dB each time the transmitter distance is doubled (if the source emits in the free field radiating in all directions of a sphere).

#### Directivity of a source.

A measure of a sound source's directivity is the directivity factor  $Q$ . To understand the meaning of this parameter, we will compare the sound propagation of two sources in a free field; one being non-directional and the other being directional.

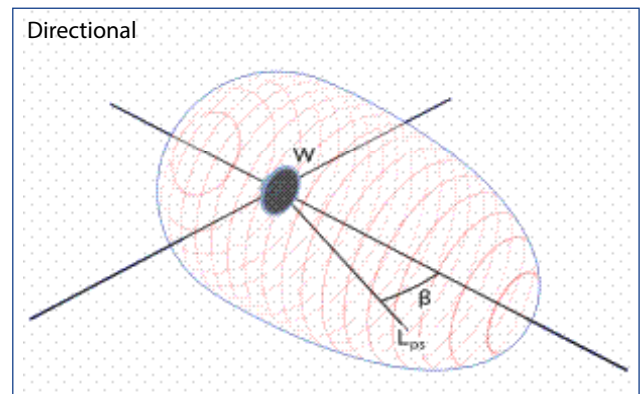
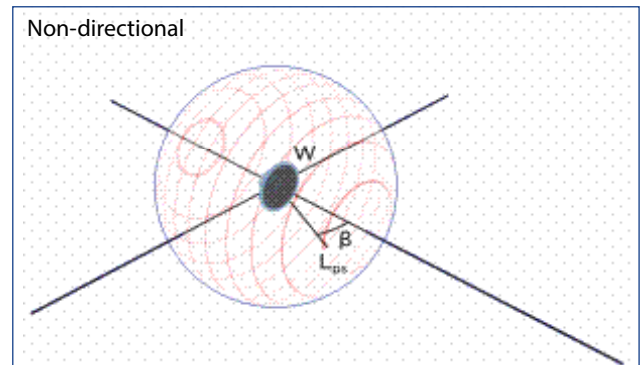

In the non-directional one, the sound pressure level is the same at any point equidistant from the source, while in the directional one, the sound pressure level values are a function of the angle between the source-observer direction and reference axes.

The directivity factor  $Q$  is defined as the ratio between the square of the sound pressure measured at a distance  $r$  and angle  $\theta$  of a sound source of power  $W$  and the square of the sound pressure measured for the same distance  $r$  from a non-directive source radiating the same power  $W$ . This definition can be rewritten as the relation between the intensity measured at a distance  $r$  and angle  $\theta$  of a sound source of power  $W$  and the intensity measured at the same distance for a source of equal power  $W$  and non-directional

$$Q_\theta = \frac{p_\theta^2}{p_r^2} = \frac{I_\theta}{I_r}$$

$$Q_\theta = \frac{10^{\frac{L_{p\theta}}{10}}}{10^{\frac{L_{pr}}{10}}}$$

$$Q_\theta = 10^{\frac{L_{p\theta} - L_{pr}}{10}}$$

$$L_{p\theta} - L_{pr} = 10 \log Q_\theta$$

$L_p$  = sound pressure level measured at a distance  $r$  and angle  $\theta$  of a sound source of power  $W$  in a free field  
 $L_{ps}$  = sound pressure level measured at a distance  $r$  from a non-directional source of sound power  $W$  in a free field

**Directivity index DI**

The directivity index DI is defined as

$$DI_\theta = 10 \log Q_\theta$$

or

$$DI_\theta = L_{p\theta} - L_{pr}$$

In the case of a non-directive source radiating spherically, it has a value of  $Q = 1$  and a  $DI = 0$  for all angles.

**Sound pressure level and directivity**

The sound pressure level for a non-directional source is

$$L_{pr} = 10 \log \frac{p^2}{4 \cdot 10^{-10}}$$

if we consider

$$I = \frac{p^2}{\rho c}$$

$\rho$  = density  
 $c$  = speed of sound

assuming that  $c = 400$ , the area of a sphere  $4\pi r^2$  and that  $I = W/\text{area}$ , we have

$$L_{pr} = 10 \log \left( \frac{W 10^{12}}{4\pi r^2} \right)$$

where we find that

$$L_{pr} = 10 \log \frac{W Q_\theta 10^{12}}{4\pi r^2}$$

that logarithmically results in

$$L_{p\theta} = L_w + DI_\theta - 20 \log r - 11$$

### Determination of the directivity

Below, we will determine the way of finding out the directivity of a source in different emission cases. The same source has different ways of propagating its sound to the environment; these forms depend on the way in which this source is placed with respect to the environment. It can be suspended so that the radiation of the source is spherical, or it can be supported on a reflective surface with which the radiation is only possible in a hemisphere, or it can be supported on two surfaces, whereby the propagation is only possible in a quarter sphere.

### In spherical propagation

The directivity index of a free field (spherical) source at a given angle  $\theta$  and a given band is calculated as

$$DI_{\theta} = L_{p\theta} - \langle L_{p\Omega} \rangle$$

$L_p$  = sound pressure level measured at a distance  $r$  and angle  $\theta$  from a sound source of power  $W$

$L_{p\Omega}$  = level of average sound pressure level in a sphere with radius  $r$

### In hemispherical propagation

The directivity index of a source emitting on a rigid plane at a certain angle  $\theta$  and at a certain band is calculated as

$$DI_{\theta} = L_{p\theta} - \langle L_{p\Omega} \rangle + 3$$

$L_p$  = sound pressure level measured at a distance  $r$  and angle  $\theta$  from a sound source of power  $W$

$L_{pH}$  = level of average sound pressure level in a hemisphere with radius  $r$

The 3 dB added to  $L_{pH}$  is due to the fact that the radiated intensity in a hemisphere is double than that in a complete sphere. This fact means that the directivity index of a non-directional source emitting on a rigid plane has a value of  $DI = DI = 3$  dB.

### In quarter spherical propagation

Many sound sources in their final location have more than one associated reflective surface (wall-ceiling, floor-wall) with which the propagation does not occur in a hemisphere but in  $\frac{1}{4}$  of a sphere.

In these cases, the directivity index will be calculated as

$$DI_{\theta} = L_{p\theta} - \langle L_{p\Omega} \rangle + 6$$

$L_p$  = sound pressure level measured at a distance  $r$  and angle  $\theta$  from a sound source of power  $W$

$L_{pQ}$  = level of average sound pressure level in a quarter sphere with radius  $r$

### In 1/8 spherical propagation

Many sound sources in their final location have more than two associated reflective surface with which the propagation does not occur in a  $\frac{1}{8}$  of a sphere but in  $\frac{1}{8}$  of a sphere.

In these cases, the directivity index will be calculated as

$$DI_{\theta} = L_{p\theta} - \langle L_{p\Omega} \rangle + 9$$

$L_p$  = sound pressure level measured at a distance  $r$  and angle  $\theta$  from a sound source of power  $W$

$L_{pQ}$  = level of average sound pressure level in a quarter sphere with radius  $r$

**Sound propagation directivity**

Directivity factor (Q)

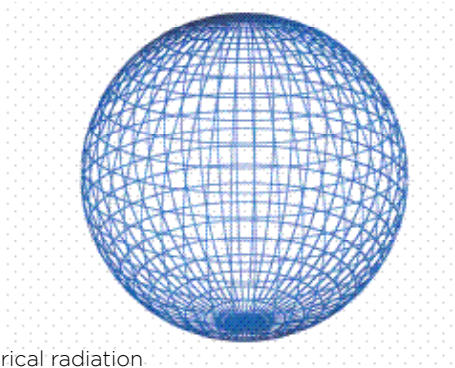

a Spherical radiation  
Q = 1

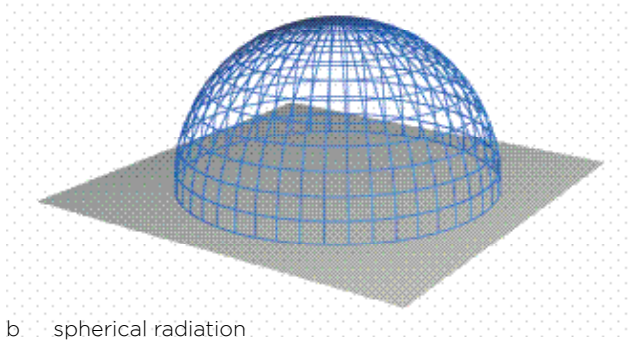

b Spherical radiation  
Q = 2

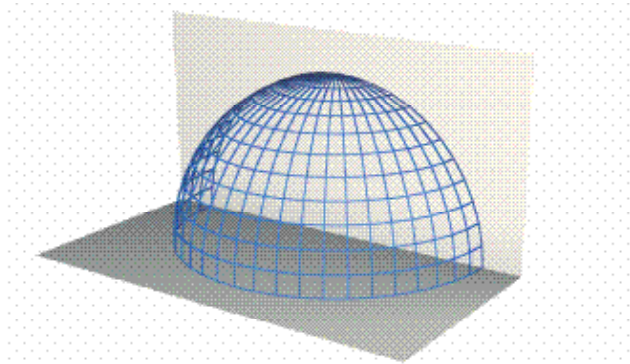

c Spherical radiation  
Q = 4

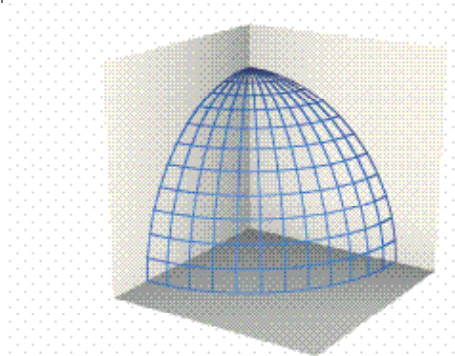

d Spherical radiation  
Q = 8

## 2.3. Sound propagation in enclosures

### 2.3.1. Direct field and reverberant field

The sound waves radiated by a source located in a closed room suffer by propagating a series of reflections against the surfaces of the enclosure inside, losing part of their energy through them being absorbed by them. The number of these reflections will depend inversely on the acoustic absorption of the enclosure.

In most practical situations, there is a homogeneous distribution of the sound energy and directions of origin of the waves inside the premises, which fulfils the conditions of the reverberant field. In addition, and overlapping with the previous one, a direct field is generated by the sound energy radiated by the source and which propagates in the air from the source to the observer.

The sound pressure level at any indoor point of a closed enclosure will be the result of the contributions of the direct and reverberant fields. This level of sound pressure can be expressed by the following:

$$L_p = L_w + 10 \log \left( \frac{Q}{4\pi r^2} + \frac{4}{R} \right)$$

- $L_p$  = sound pressure level at the position considered
- $L_w$  = sound power level of the source
- $r$  = distance between the sound source and the considered position
- $Q$  = directionality factor of the source
- $R$  = constant of the enclosure, defined as:

$$R = \frac{S\alpha}{1-\alpha}$$

- $S$  = total surface of the enclosure
- $\alpha$  = average absorption of the enclosure calculated as:

$$\alpha = \frac{\sum_{i=1}^N \alpha_i s_i}{\sum_{i=1}^N s_i}$$

- $\alpha_i$  = absorption coefficient of the surface material
- $s_i$  = surface of each absorbent material

This equation describes in a simple form the sound field in any interior point of the enclosure, and enables us to identify the relative importance of the contributions of the direct and reverberant fields. In effect:

- If the acoustic absorption of the premises is minimal or null ( $R$  is small), the  $4/R$  term predominates in the parenthesis of the previous equation. In this case, the sound level  $L_p$  is constant in any position of the enclosure and of the sound sources. In this case, we will be in the reverberant field conditions.
- If there is a high level of acoustic absorption in the room ( $R$  is high), the term  $Q/4\pi r^2$  predominates in the parenthesis of the previous equation. In this case, the sound level  $L_p$  decreases with the distance between the source and position of the enclosure. In this case, we will be in the direct field conditions.

The following figure shows the characteristic variation of the sound pressure level with the distance from the sound source for enclosed spaces.

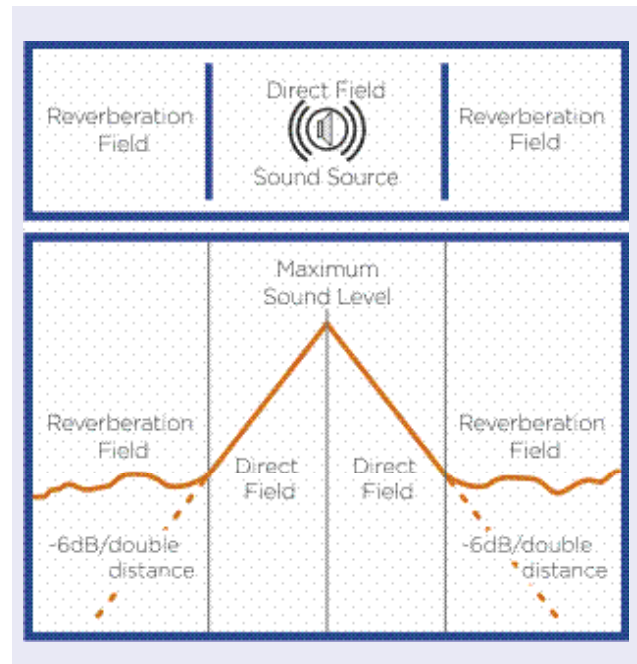

In this figure, it can be seen that in the vicinity of the machine there is a clear predominance of the direct field with drops of 6 dB each time the distance doubles in the case of point sources, while from a certain distance the sound level remains constant with the prevalence of the reverberant field. This is in the area where there is a predominance of the reverberant field where, by increasing the acoustic absorption of the enclosure, the sound levels can be reduced.

**2.3.2. Absorption coefficients**

The absorption coefficient, which is defined as the quotient between the energy absorbed and the incident, depends on both the type of material and on its assembly form, influencing the type of absorption mechanism that is developed.

$$\alpha = \frac{E_a}{E_i}$$

Summarising the considerations detailed previously, it can be concluded that:

- Absorption increases with frequency.
- For high frequencies, absorption does not depend on the thickness of the material.
- For low frequencies, absorption increases with thickness.

The following figures show the acoustic absorption of a mineral wool type material for different types of assemblies, thicknesses, densities and distances to a rigid wall.

The increase at low frequencies of the absorption can be noticed when separating the material from the rigid wall.

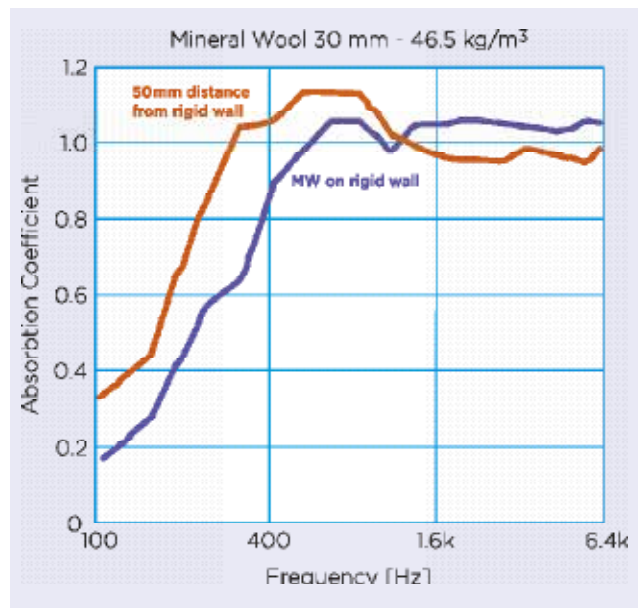
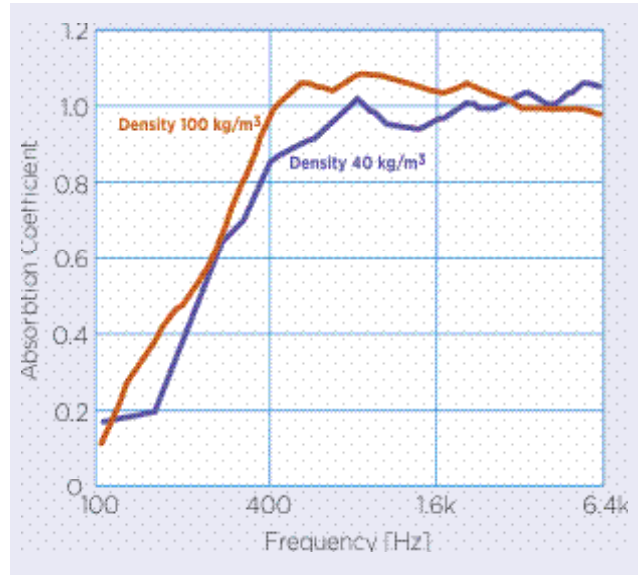

### 2.3.3. Reverberation

The propagation of sound in enclosed spaces is influenced by the presence of the surfaces that limit it and by the elements inside it. The sound waves hitting the walls lose some of their energy by being absorbed by the walls.

In the ideal case in which the materials that make up the walls of an enclosure are totally absorbent, there would be no reflections and the propagation would be similar to that which occurs in free-field or anechoic situations. If, on the contrary, the walls were totally reflective, the sound waves would suffer a great number of reflections and we would define the field as reverberant. In practice, situations are never totally anechoic or reverberant since there is always a certain amount of acoustic absorption in the enclosures.

The phenomenon of reverberation can be understood as the prolonged extinction of the sound due to the multiple reflections that occur in the enclosure and the absorption of the air that this encloses. In other words, reverberation can be understood as the existence of a sound in a room after its emission has ceased, motivated by multiple reflections on the surfaces of the premises. The reverberation time of an enclosure is a measure of the permanence of the sound energy in the enclosure once the sound source that produced it has ceased. Although there are a large number of parameters to partially define the acoustic quality of an enclosure, the reverberation time is undoubtedly the parameter that best characterises the acoustic quality of an enclosure.

A reverberation is perceived when the reflected sound wave reaches your ear in less than 0.1 second after the original sound wave. Since the original sound wave is still held in memory, there is no time delay between the perception of the reflected sound wave and the original sound wave. In the case that the difference is greater than 0.1 second, it is known as echo.

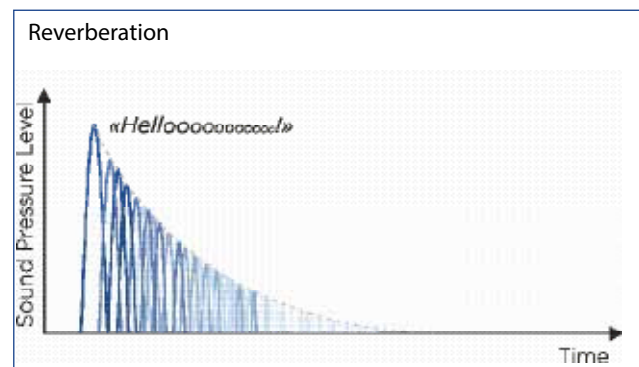
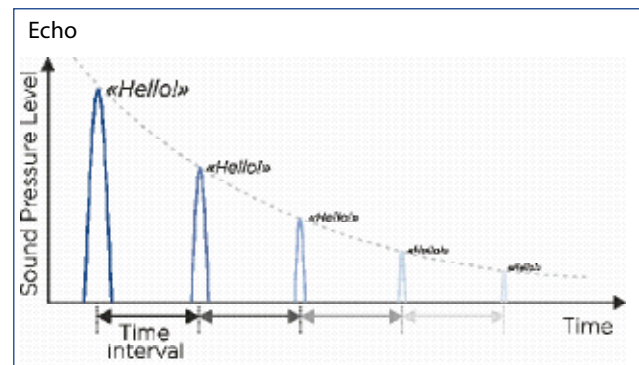

**Measurement of reverberation**

The reverberation time, by agreement, is considered the time necessary for the intensity of the sound that is extinguished to be reduced to one millionth of the initial intensity of emission. This translated into sound pressure levels means that the reverberation time is the time necessary for the sound pressure level to drop 60 dB following the cessation of a sound emission.

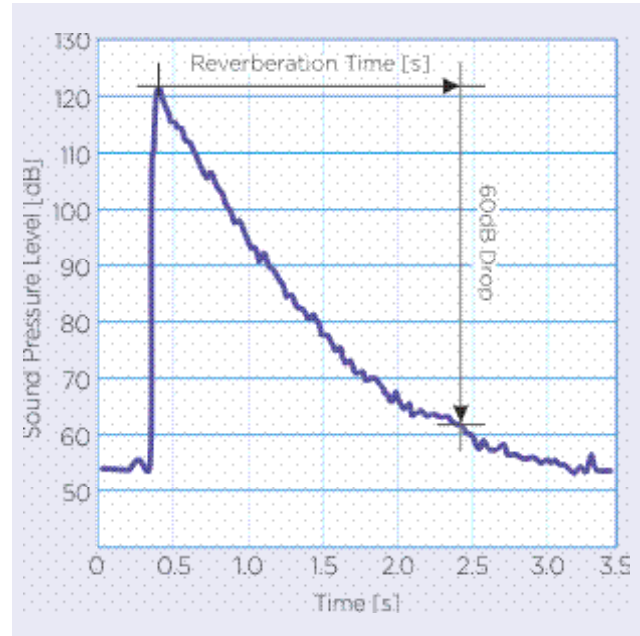
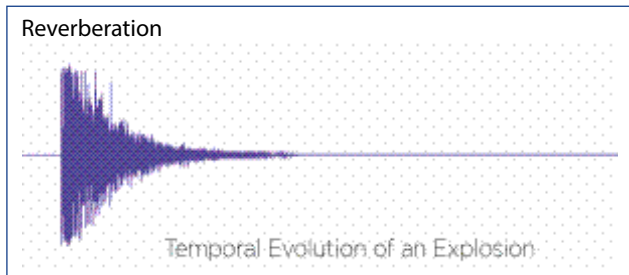

When measuring the reverberation time, two possibilities are available. The absorption of the sound produced by the explosion of a pyrotechnic element can be registered, or the emission of a sound can be maintained and recorded as it is absorbed once the emitter has been disconnected (e.g. a loudspeaker reproducing pink noise). The following figures show what the temporal evolution of the sound level would be in both cases.

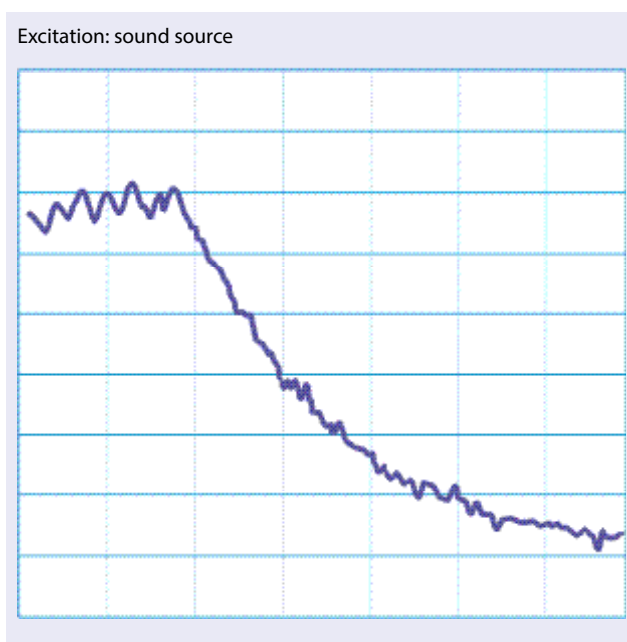
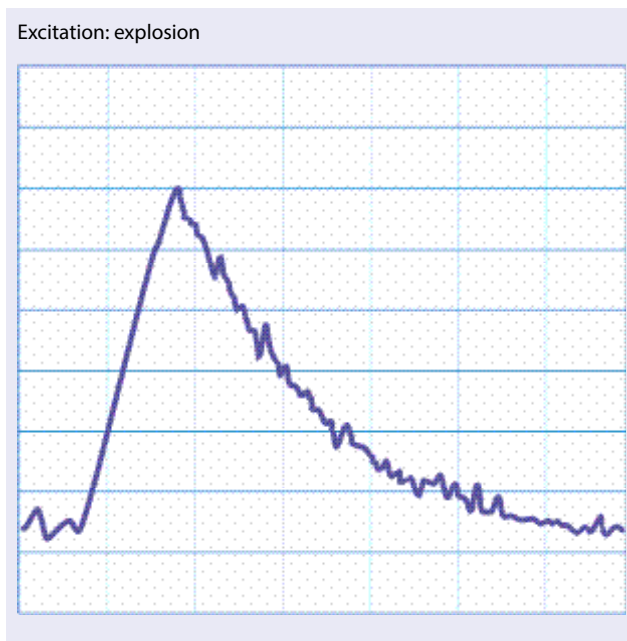

If the decay of the sound level in a room is a function of the absorbent properties of the materials that make up its walls, it should be clear that, because the absorbent properties of the materials are a function of the frequency of the sound that impacts on them, the reverberation time will also clearly depend on the frequency. That is why for the correct description of the reverberation in an enclosure, the reverberation time must be detailed by frequency bands either in octave bands or in bands of thirds of an octave.

When measuring the reverberation experimentally, an analysis in octave bands between 125 Hz and 4 kHz is basically used. If an explosion is used as an excitation source, it has a relatively flat spectrum that allows us to have a high level of sound in all the frequency bands (at low frequencies, we can have some problems on certain occasions). If a sound source is used as excitation, it will be sufficient to excite the speaker with a recording with pink noise (equal sound level in all the octave bands).

There are cases in which it is impossible to achieve a 60 dB drop since the source used as excitation does not exceed the sound level of the room by 60 dB (e.g., what usually happens when measuring the reverberation in industrial plants with high background levels). In these cases, a certain fall is measured, which must be at least between 20 and 25 dB, and the data are extrapolated linearly until a drop of 60 dB. The following figure shows an example in which a 40 dB drop is recorded.

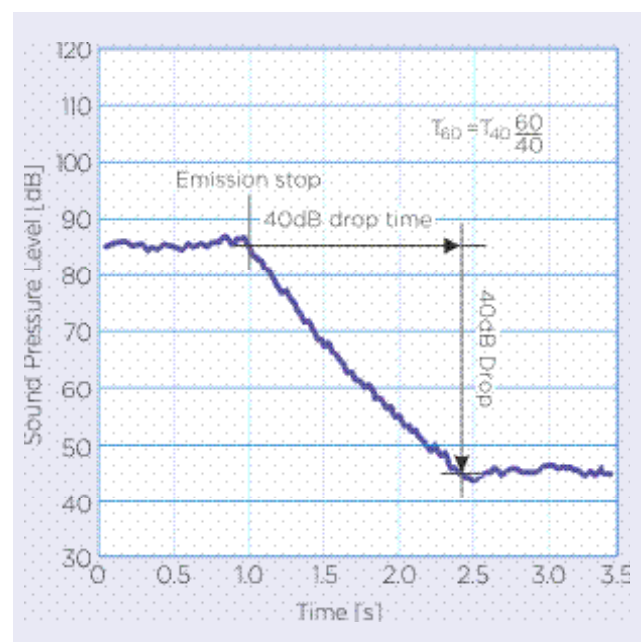

At the same time, the reverberation time is a measure of the absorbent or reflective properties of the interior surfaces of the room. If these absorbent properties are known for all the materials that are going to be used in the construction of the enclosure, and its distribution therein is known, approximate estimates of this reverberation time can be made in the design phase.

There is a large number of formulations aimed at theoretically calculating the reverberation times of an enclosure. From Sabine's initial formulations to the present day, a large number of researchers have tried to find formulations that would be useful in any of the different configurations and types of enclosures.

The simplest expression for calculating the reverberation time is the Sabine equation:

$$T_{\text{sa}} = \frac{0.161V}{s\alpha_m + 4mV}$$

$V$  = volume of the enclosure  
 $s$  = sum of the surfaces present inside the enclosure  
 $\alpha_m$  = average absorption of the enclosure  
 $4mV$  = contribution of the absorption of the volume of air inside the enclosure  
 Normally the term  $4mV$  is negligible compared to  $s\alpha_m$ .

$$T_{\text{sa}} = \frac{0.161V}{s\alpha_m}$$

Although the exact value of the constant  $m$  depends on the temperature and % relative humidity, a very valid approximation only considers its dependence on % relative humidity. This approximation enables the value of  $m$  to be calculated by:

$$m = 5.5 \cdot 10^{-4} \frac{50}{0/0} \left( \frac{f}{1000} \right)^{1.7}$$

% = percentage of relative humidity of the air inside the enclosure  
 $f$  = sound frequency

The importance of the acoustic attenuation offered by the air depends on the total absorption values of the enclosure and its volume. In general, it will be important for large volumes, especially when the absorption of these is very small (e.g. industrial buildings).

In general, it can be established that the Sabine equation presents an adequate margin of precision in most practical situations, even admitting that for values of absorption coefficients greater than 0.2 to 0.3, the error in the calculation of the reverberation time is around 10 %.

The Eyring-Norris and Millington-Sette equations are among the formulations that have been proposed to correct the imperfections of the Sabine equation.

The Eyring-Norris equation calculates the reverberation time using the expression:

$$T_{\text{en}} = \frac{0.161V}{-s \ln(1 - \alpha_m)}$$

The results obtained with this equation agree with those measured experimentally in those cases in which there is a high level of acoustic absorption inside the enclosure. The more uniform the distribution of acoustic absorption in the interior, the more accurate are the results provided by this equation.

The Millington-Sette equation calculates the reverberation time using the expression:

$$T_{\text{ms}} = \frac{0.161V}{-\sum_i s_i \ln(1 - \alpha_i)}$$

It is experimentally proven that this equation is the most suitable for predicting the reverberation times in those enclosures where there is a great variety of different materials and with very varied absorption coefficients.

The application of the Millington equation offers erroneous values if some absorption coefficient of some material or element has values close to 1. In such cases, problems arise from the need to calculate the term:

$$\ln(1 - \alpha_i)$$

If there are areas that are not enclosed by any wall, these surfaces are treated in the simulations as "open windows"; that is, all the sound energy that reaches these surfaces escapes from the enclosure and does not return in the form of reflection. Due to this, the absorption coefficients of these surfaces are assigned the value 1 (all the energy that arrives escapes and does not return, for example, long corridors in a wall of the enclosure).

In practice, when some absorption coefficient has the unit value, the reverberation time according to Millington is not used. When the coefficients have values close to unity, but are lower, we should be aware that the calculated values will be strangely small. To avoid this situation, the solution that is usually proposed is to average small highly absorbent surfaces with those other larger surfaces and with lower absorption coefficients.

### 2.3.4. Acoustic conditioning

The purpose of acoustically conditioning a given enclosure is to ensure that the sound coming from a source or sources is radiated equally in all directions, achieving an ideal fuzzy sound field, improving the acoustic conditions of sound as well as comfort. In industry, it is most common to reduce the sound level in the enclosure by minimising the reverberation time of the industrial enclosure concerned, assuming that

- The spectrum of frequencies to be absorbed is perfectly known.
- The absorption coefficients of the materials to be used and their variation as a function of frequency are perfectly known.
- There is an attempt to solve the absorption only with superficial absorbent materials, trying to maintain the diffuse field conditions.
- If bands remain for absorption, at low frequencies, there is recourse to selective absorption elements such as resonators and membranes.

This sound pressure reduction can be calculated starting from the reverberation times before and after applying the absorbent materials, according to the relationship:

$$\Delta L_p = 10 \log \frac{T_1}{T_2}$$

$T_1$  = reverberation time before treatment, [s]

$T_2$  = reverberation time after treatment, [s]

The formula most used for the calculation is the Sabine equation:

$$T_{\text{Sab}} = \frac{0.161V}{A} \qquad T_{\text{Eyr}} = \frac{0.161V}{S\alpha_m}$$

$T$  = reverberation time, [s]

$V$  = enclosure volume, [m<sup>3</sup>]

$A$  = absorbing area of the room, [m<sup>2</sup>]

This equation is applicable, especially in enclosures that are not very large, where the surfaces that limit them have a uniform absorption coefficient and whose value does not exceed 0.2.

For values of the upper absorption coefficient and whenever there is a certain uniformity between these, it is more convenient to use the Eyring equation:

$$T_{\text{Eyr}} = \frac{0.161V}{-S \ln(1 - \alpha_m)}$$

where:

$$\alpha_m = \frac{\alpha_1 \cdot S_1 + \alpha_2 \cdot S_2 + \dots + \alpha_n \cdot S_n}{S_1 + S_2 + \dots + S_n}$$

$V$  = room volume, [m<sup>3</sup>]

$S$  = sum of the surfaces that limit the room, [m<sup>2</sup>]

$\ln$  = Napierian logarithm

$\alpha_m$  = average absorption coefficient of the surfaces that limit the enclosure

$S_1, S_2, \dots, S_n$  = surfaces that limit the enclosure, [m<sup>2</sup>]

$\alpha_1, \alpha_2, \dots, \alpha_n$  = absorption coefficient of the different surfaces that limit the enclosure

For very different absorption coefficient values, it is more accurate to use the Millington equation:

$$I_{\text{m}} = \frac{0.161V}{-\sum_j S_j \ln(1-\alpha_j)}$$

where:

$$\sum_{j=1}^{j=n} S_j \ln(\alpha_j) = S_1 \cdot \ln(1 - \alpha_1) + S_2 \cdot \ln(1 - \alpha_2) + \dots + S_n \cdot \ln(1 - \alpha_n)$$

V = room volume, [m<sup>3</sup>]

ln = Napierian logarithm

S<sub>1</sub>, S<sub>2</sub> ..., S<sub>n</sub> = surfaces that limit the enclosure, [m<sup>2</sup>]

α<sub>1</sub>, α<sub>2</sub> ..., α<sub>n</sub> = absorption coefficient of the different surfaces that limit the enclosure

Certain enclosures can be the focus of a loud noise level if precautions are not taken. This is the case of many industrial premises, where dangerous levels for the conservation of auditory acuity are common.

To reduce noise, two procedures can be used, depending on the case:

- Reduce the sound power emitted by constructive resources, that is, by means of suitable enclosures in the machines, or, if this is not possible, by means of partial, mobile or not, shielded screens.
- If the measurements cannot be taken, it is only possible to reduce the sound level by increasing the equivalent absorption area or, which is the same, by reducing the reverberation time.

The efficiency achieved in the level reduction can be calculated with the expression indicated above:

$$\Delta L = 10 \log \frac{A}{A_0}$$

A<sub>0</sub> = equivalent absorption area before treatment

A = equivalent absorption area after treatment

$$A = \frac{S_1 \cdot \alpha_m}{1 - \alpha_m}$$

$$\alpha_m = \frac{\alpha_1 \cdot S_1 + \alpha_2 \cdot S_2 + \dots + \alpha_n \cdot S_n}{S_1 + S_2 + \dots + S_n}$$

A = absorbing area of the room, [m<sup>2</sup>]

S = sum of the surfaces that limit the room, [m<sup>2</sup>]

α<sub>m</sub> = average absorption coefficient of the surfaces that limit the enclosure

S<sub>1</sub>, S<sub>2</sub> ..., S<sub>n</sub> = surfaces that limit the enclosure, [m<sup>2</sup>]

α<sub>1</sub>, α<sub>2</sub> ..., α<sub>n</sub> = absorption coefficient of the different surfaces that limit the enclosure

### 2.3.5. Sound absorbing materials

These are all materials or systems that have high sound absorption coefficients in all or part of the spectrum of audible frequencies. Depending on the physical properties of the material, the absorbent materials can be divided into the following groups:

<b>Porous material</b>	Rigid structure		
	Flexible structure		
<b>Resonance absorbing systems</b>	Simple	Helmholtz	
		Membrane	Membrane Bekey type
	Coupled	Series	
		Parallel: perforated panels	
<b>Mixed</b>	Combination of the above (most of the commercial absorbent materials)		
<b>Anecoic (gradual variation of physical characteristics)</b>	By real transmission		
	By geometric configuration		

The most typical, and of course the only ones, among those considered here, with characteristics of true material, are the porous materials, the rest being devices or absorbent structures. Porous materials are constituted by a solid medium (skeleton), traversed by cavities more or less tortuous (pores) connected to the outside. The degradation of the acoustic energy is produced by viscous friction of the fluid inside the cavities.

From the point of view of acoustic behaviour, it is convenient to distinguish between rigid and flexible skeletal materials. In the former, the absorption coefficient increases with frequency, while, in the latter, there are absorption resonances (maximum) at low and medium frequencies.

The resonators, as the name suggests, produce the absorption of acoustic energy through a resonance process. The resonant movement of a part of the system extracts energy from the acoustic field, selectively and preferentially, within a certain frequency band.

The anechoic absorbers, also called absorption devices with progressive variation of physical characteristics, make use of the fact that the reflection of an acoustic wave occurs when it finds a variation of the physical characteristics of the medium in which it propagates. With the gradual variation of these, it is intended to minimise the obstacle presented by the material. With these absorbents, absorption coefficients at normal incidence higher than 99 % are achieved, starting from a certain so-called cut-off frequency. Its use is specific in anechoic chambers. In practice, three materials or systems are used:

- Porous materials
- Plate resonators
- Helmholtz resonators

#### **Porous materials**

The porous materials are constituted by a structure that configures a large amount of interstices or pores that are connected to each other. Fibrous structure materials, such as mineral wools, conform exactly to this configuration. When an acoustic wave impinges on the surface of the material, a significant percentage of it penetrates through the interstices, bringing the fibres into vibration, which causes part of the acoustic energy to transform into kinetic energy. On the other hand, the air that occupies the pores starts moving; energy losses are produced by the friction of the particles with the skeleton, which is transformed into heat. Since the section that has the acoustic wave is limited by the skeleton or solid element, it is understood that the behaviour of the material will depend on its porosity. Indeed, the high acoustic absorption of the materials constituted by glass or rock fibres can be explained by their high porosity which can exceed 99 %.

However, since the layer thicknesses that are normally used are very limited, due to problems of space and cost, the acoustic absorption with porous materials is very high at high frequencies, and limited at low frequencies. Indeed, to obtain an absorption degree of 99 %, an insulation thickness for a certain frequency is necessary; equivalent to  $\lambda/4$  ( $\lambda$  wavelength).

#### **Plate resonators**

The plate resonators consist of a plate or sheet that vibrates on a cushion of air. If the plate is large enough and not too rigid, the recoil force will be defined by the stiffness of the air layer.

The degree of absorption of these resonators depends on the internal losses of the plate or sheet material and the losses at the attachment points. The said degree of absorption is rather limited to the system's resonance frequency and can be increased by filling the air space with a mineral wool absorbent material. The absorbent material introduced into the chamber dampens the vibrations reflected in the rigid wall behind the plate and does not allow for complete vibration of the plate, with this absence resulting in a reduction of the energy absorbed and, therefore, of the absorption coefficient value.

#### **Helmholtz resonators**

The constitution of Helmholtz resonators is essentially the same as plate resonators, with the difference that the plate or sheet has perforations. As with plate resonators, the air space must be perforated in order to avoid the propagation of sound parallel to the plate. The size of the perforations should be small compared to the wavelength of the sound to be damped. With this type of resonator, a high degree of absorption for the medium frequency range is achieved for a limited thickness. The damping in this case is determined by the friction of the air with the walls of the perforations, accompanied by a release of heat. As in the case of plate resonators, the filling of the air space with a porous material based on mineral wool increases the degree of absorption.

### 2.3.6. Acoustic properties of mineral wool

Mineral wools used in industry contribute to protection against noise. The characteristics that define their acoustic behaviour are determined by:

- Resistance to the air flow,  $r$  [ $\text{kPa} \cdot \text{s}/\text{m}^2$ ]
- Dynamic rigidity,  $s'$  [ $\text{MN}/\text{m}^3$ ]
- Acoustic absorption,  $\alpha_s$  (dimensionless)

In the field of industrial applications, the acoustic absorption capacity is an indispensable feature. Thanks to the nature of its open and elastic structure, ISOVER mineral wool offers optimal insulation and acoustic performance.

#### Resistance to the air flow, $r$

The resistance to the passage of air, is a useful parameter for estimating the acoustic absorption and the possible internal flows of convection in the insulating material.

This is an intrinsic property of all absorbent materials that makes it possible to determine the suitability of the material's acoustic behaviour. It is the capacity to reduce the transmitted acoustic energy, decreasing the speed of sound within the mineral wool:

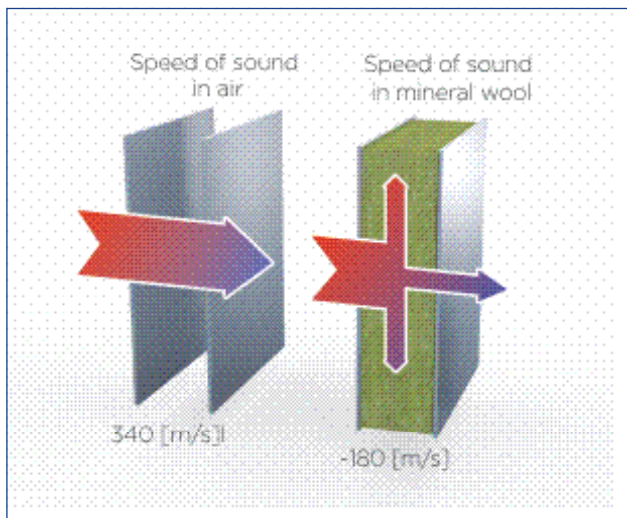

The resistance to the flow of air represents the result of the friction produced between the filaments of the mineral wool and the air particles inside it. This property will fundamentally depend on the length and diameter of the filaments of the mineral wools, which determine their acoustic behaviour.

The optimum value of the resistivity to the passage of air must be between 5 to 50  $\text{kPa} \cdot \text{s}/\text{m}^2$  (the acoustic behaviour with equal thickness is similar). Below 5  $\text{kPa} \cdot \text{s}/\text{m}^2$ , the insulator will not provide sufficient acoustic damping, and above 50  $\text{kPa} \cdot \text{s}/\text{m}^2$ , the noise will be predominantly transmitted via something solid because it is excessively rigid material.

The resistivity to the passage of air,  $r$ , is determined by the test carried out according to the EN 29053 standard, required for the products that fill the chambers.

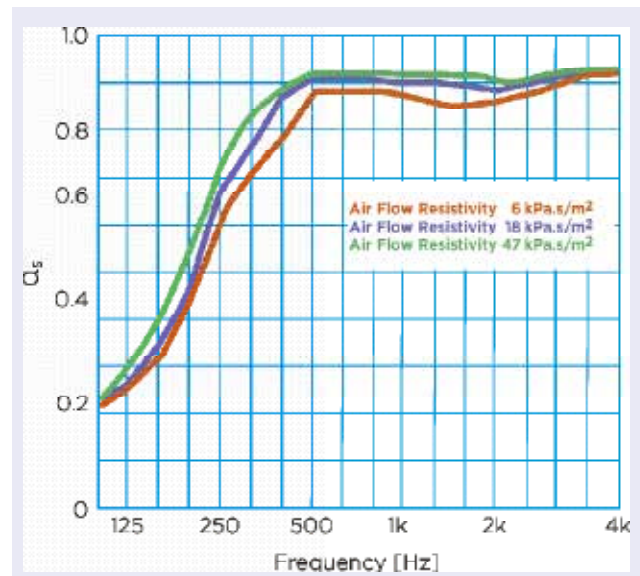

Air flow resistance (DIN EN 29053) $\text{kPa} \cdot \text{s}/\text{m}^2$			
ULTIMATE		Stone wool	
24 - 30 [ $\text{kg}/\text{m}^3$ ]	$\geq 13$	30 - 50 [ $\text{kg}/\text{m}^3$ ]	$\geq 5$
40 - 50 [ $\text{kg}/\text{m}^3$ ]	$\geq 30$	70 [ $\text{kg}/\text{m}^3$ ]	$\geq 18$
60 - 70 [ $\text{kg}/\text{m}^3$ ]	$\geq 48$	100 [ $\text{kg}/\text{m}^3$ ]	$\geq 25$
80 - 100 [ $\text{kg}/\text{m}^3$ ]	$\geq 70$	120 [ $\text{kg}/\text{m}^3$ ]	$\geq 35$

**Dynamic rigidity,  $s'$**

This is the capacity of mineral wool to act as a spring, absorbing noise and vibration. Dynamic rigidity is necessary for noise and vibration calculations.

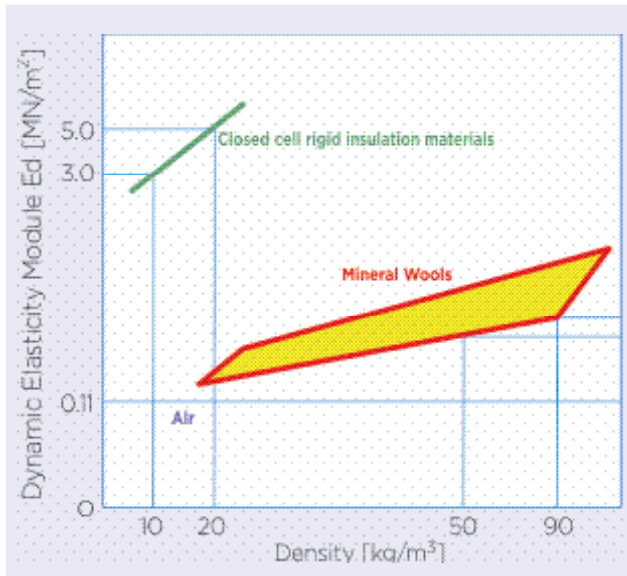

$$s' = \frac{E_d}{d}$$

- $S'$  = dynamic rigidity of the material [MN/m<sup>3</sup>]
- $E_d$  = dynamic elasticity module [MN/m<sup>2</sup>]
- $d$  = thickness of the material [m]

The dynamic rigidity  $s'$  is determined by the test carried out in accordance with the standard EN 29052-1, required for products used in floating floors and elastic bands.

**Acoustic absorption, or  $\alpha$**

As we saw in 2.3.2, absorption is the phenomenon due to which part of the acoustic energy that hits a surface is absorbed transforming into heat.

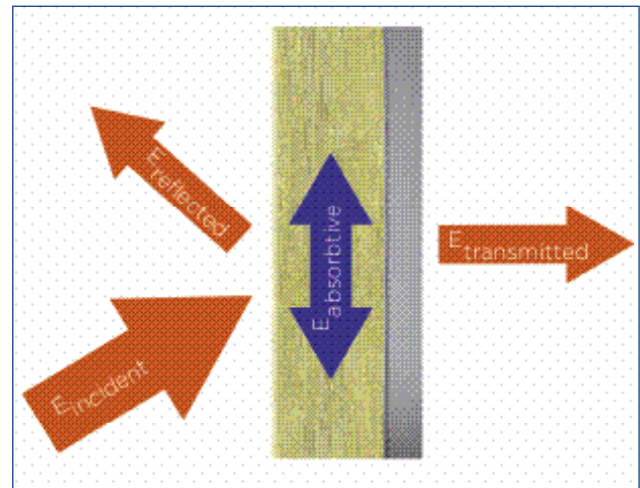

When a wave front arrives at a vertical parameter that separates two enclosures, part of the incident energy is reflected by the face, another part of this energy is absorbed and the rest finally passes through the face.

The incident sound energy,  $E_i$ , will respond to the following energy balance (principle of energy conservation):

$$E_i = E_a + E_r + E_t$$

- $E_i$  = incident energy
- $E_a$  = energy absorbed by the parameter
- $E_r$  = reflected energy
- $E_t$  = transmitted energy

Dividing member to member the previous expression between  $E_i$ , we have:

$$1 = \alpha + r + t$$

- $\alpha = E_a / E_i$  is the acoustic absorption coefficient; it is dimensionless and is expressed as either one or a percentage (dimensionless)
- $r = E_r / E_i$  is the acoustic reflection coefficient (dimensionless)
- $t = E_t / E_i$  is the transmission or acoustic transmissibility coefficient (dimensionless)

Therefore,  $\alpha$  represents the amount of incident energy that said material is capable of absorbing; it is dimensionless and in porous materials it depends on several parameters:

- Resistance to the air flow
- Sound frequency
- Porosity (air volume/total volume)
- Tortuosity (geometry of the material's structure)
- Thickness

The acoustic absorption coefficient of the materials is measured in a reverberation chamber for a given frequency (according to the measurement standard EN-ISO 354) and is called the "Sabine" absorption coefficient or is represented as  $\alpha$  or  $\alpha_s$ .

By its own definition, the acoustic absorption coefficient:

- Is an acoustic parameter between 0 and 1.
- Traditional construction materials (steel, concrete) have very low absorption coefficients (they tend to reflect almost all the acoustic energy they receive)
- The mineral wools have very high absorption coefficients and are characterised by the fact that the nature of their surface allows the sound energy to penetrate through the material's pores.

The acoustic absorption,  $\alpha_s$ , is determined by the test carried out in accordance with the standard EN ISO 354, which is required for products that are used as acoustic absorption.

### 2.3.7. Acoustic insulation

Sound is insulated by preventing its propagation by means of reflective obstacles. As already indicated in section 2.3.2, whenever it is a matter of achieving a great reflection factor, it is necessary to insert into the sound path a medium whose impedance  $Z$  is as different as possible from the medium driving the sound path; therefore, it is logical to treat the insulation of sound in the air or other gaseous medium (low impedance) on the one hand, as well as the insulation in solids (high impedance) on the other. The sound transmitted by the air is what is usually called airborne noise, which is what we will call it hereinafter. If we place a barrier between two rooms to achieve an insulation of airborne noise, the noise can be transmitted from one room to another in different ways as seen in the following figure.

Paths of noise transmission

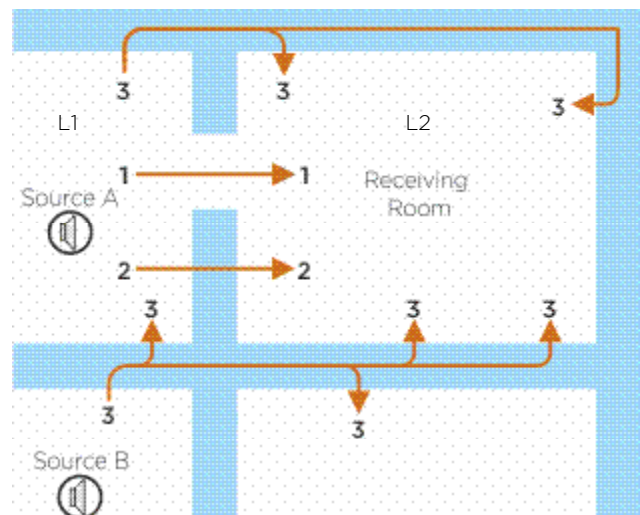

- Directly (2), which can be broken down into two main causes.
  - Porosity through fissures and interstices.
  - The diaphragm effect, that is, flexion under the effect of sound pressure, as in a membrane.
- By indirect means, such as conduits (1) and adjacent walls (3).

There are several standardised indices for quantifying airborne sound insulation. Let's take a look at those that are used most:

Acoustic insulation (D): This is the difference in sound pressure levels between the acoustic level of the room where the source is (emitting room) and that of the room where the sound is received (receiving room). It is determined on site by the expression:

$$D = L_1 - L_2 \quad \text{dB}$$

This value can correspond to a single frequency, a frequency band or the total spectrum of frequencies.

#### Standardised acoustic insulation ( $D_n$ )

This is the difference of acoustic pressure levels between the emitting and the receiving room but taking into account the influence exerted by the reverberation above the level. In the receiving room, if there is a high level of reverberation, the value of the acoustic level  $L_2$  is greater than what would be expected due to the insulation produced by the wall, with which the acoustic insulation is reduced. The opposite will occur in the case of high absorption: low reverberation. To take this incidence into account, the results are corrected, considering that one room has a reference reverberation time of 0.5 seconds, or, according to another standard, an equivalent absorption area of 10 m<sup>2</sup>.

Therefore, the standardised acoustic insulation, for a given frequency between two enclosures, is calculated on site by the expression:

$$D_n = L_1 - L_2 + 10 \log \frac{T}{0,5} \quad \text{dB}$$

$$D_n = L_1 - L_2 + 10 \log \frac{10}{A} \quad \text{dB}$$

T = reverberation time of the receiving room for the considered frequency

A = equivalent absorption area of the receiving room for the considered frequency

#### Acoustic reduction index (R)

This index is determined by laboratory measurements and is defined as:

$$R = 10 \log \frac{W_1}{W_2} \quad \text{dB}$$

$W_1$  and  $W_2$  are the incident acoustic powers on the sample and transmitted by it. In the case of the diffuse acoustic field, which is how it is tested in the laboratory, it can be evaluated by the formula:

$$R = L_1 - L_2 + 10 \log \frac{S}{A} \quad \text{dB}$$

where:

S = surface of the sample to be tested, [m<sup>2</sup>]

A = equivalent absorption area of the receiving room, [m<sup>2</sup>]

**Airborne noise insulation of single-sheet partitions**

The acoustic airborne noise reduction index of a construction element R, is a function of several physical magnitudes, such as the frequency of the incident sound, the mass of the constructive element, the rigidity of the partition, the resonance frequencies and the coincidence effect.

For simple partitions of one sheet, it is possible to distinguish four zones of distinct behaviour in the graph of the acoustic reduction index as a function of frequency.

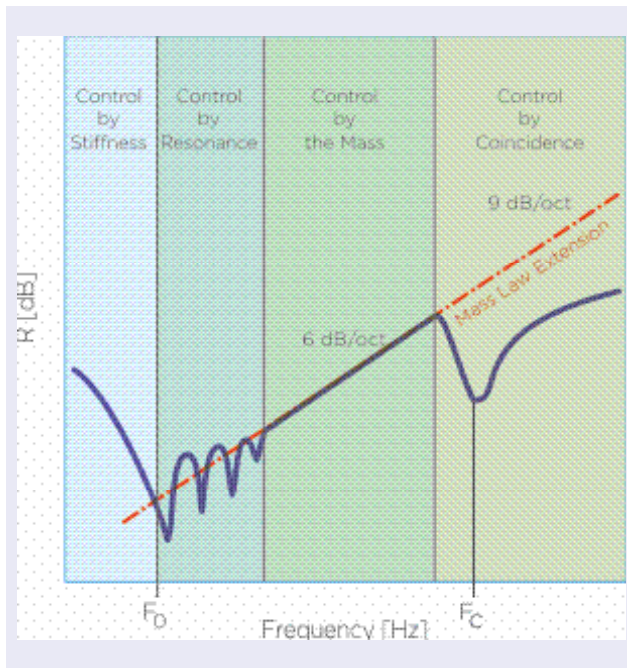

**Zone controlled by stiffness**

At low frequencies, airborne sound insulation is controlled by the stiffness of the partition. The greater the rigidity, the lower the airborne sound insulation.

The natural frequency of a solid wall is well determined by the expression:

$$f_0 = \frac{1}{2\pi} \sqrt{\frac{s}{m'}}$$

s = stiffness of the wall per unit of area  
 m' = mass of the wall per unit of area

For f < f<sub>0</sub>

$$R = 20 \log s - 20 \log f - 20 \log 4\pi\rho c$$

The insulation is determined by the elastic stiffness and decreases 6 dB/octave with increasing frequency. If the sheet is light, the insulation is given by:

$$R = 20 \log \frac{\rho_1 c_1}{4\rho_2 c_2}$$

**Zone controlled by resonance**

The wall has many of its own ways of vibration, which correspond to the resonance frequencies; these frequencies depend on the dimensions, the stiffness and the mass per unit of area. The resonance frequencies for a finite simple partition are given by the expression:

$$f = kh \sqrt{\frac{R}{\rho(1-\nu^2)}} \left[ \left(\frac{p}{a}\right)^2 + \left(\frac{q}{a}\right)^2 \right] \text{ Hz}$$

- p, q = 1, 2, 3
- a, b = dimensions of the partition
- ν = Poisson's coefficient, in most cases 1/3
- k = numerical coefficient that depends on the way of fixing the partition edges
- K = 0.43 for supported edges
- k = 0.86 for embedded edges
- f<sub>11</sub> = predominates, large values of a and b reduce f<sub>11</sub>

### Zone controlled by mass

From frequency values higher than twice the resonance frequency  $f_{11}$  and lower than the critical frequency, the insulation is controlled by the mass and frequency, and is given by the following expressions:

- a) Law of normal incidence mass  
Incidence angle of  $0^\circ$

$$R_{(\varphi=0)} = 20 \log(m'f) - 42$$

- b) Law of mass at random incidence  
For angles between  $0^\circ$  and  $90^\circ$

$$R \cong R(0) - 10 \log[0.23R(0)]$$

- c) Law of mass at field incidence

In practice, closer to reality is the expression of airborne sound insulation with incidence angles of  $0^\circ$  to  $78^\circ$ , field incidence, and is given by:

$$R = R(0) - 5 = 20 \log(m'f) - 47$$

From here, the following considerations can be deduced:

**The acoustic reduction index increases by 6 dB per octave** (increases 6 dB by doubling the frequency). That is, it will always be much easier to insulate high frequencies than low ones. This has the additional advantage that the human ear is less sensitive to low frequencies, but it is harmful in terms of the structural resonances that are important for low frequencies in the building, creating large amplifications that are difficult to insulate.

**The acoustic reduction index increases 6 dB by doubling the area mass of the panel.** This would lead us to conclude that the walls should be as thick as possible in order to get good insulation. This is logical from an acoustic perspective, but not from a constructive one. This thickness can be substituted in some way by multiple walls, which usually gives a very acceptable result.

### Zone controlled by coincidence

In the air, the sound is propagated by longitudinal waves and its speed is the same for all frequencies. When there is a localised forced deformation in a solid, free waves that propagate throughout the solid are generated. If the partition of a sheet is thin enough, bending waves occur, which, unlike other types of wave, propagate with a speed as a function of frequency. There will therefore be a critical frequency in which the wavelength of the sound in the air coincides with the wavelength of the bending. This is known as a coincidence effect. The critical frequency of coincidence is defined as the lowest frequency at which the coincidence effect occurs and corresponds to an incidence angle of  $90^\circ$ .

The elements of the partition are affected by two waves, the incident air wave, and the bending wave. The trace of the air wave advances through the partition at a speed of  $c/\sin \theta$  and the bending wave at a speed of  $c_p$ . When the two speeds along the partition are equal, the effects accumulate and a high level of energy is radiated through the partition. The loss of airborne sound insulation is important in a frequency range somewhat above the coincidence frequency. The decrease in insulation depends on the loss factor of each material,  $\alpha$ .

$$\lambda_f = \frac{\lambda}{\sin \theta}$$

If the wavelength of sound in the air is greater than the length of the bending wave in the partition, there can be no coincidence effect since the sine function cannot be greater than the unit. In the case of a partition of a homogeneous sheet, the propagation speed of the bending waves,  $c_p$ , is given by:

$$c_p = c \sqrt{\frac{f_c}{f}}$$

- $c$  = speed of sound in air  
 $f$  = considered frequency  
 $f_c$  = critical frequency of the partition

The critical frequency of the partition is obtained from the expression:

$$f_c = \frac{c^2}{2Hd} \sqrt{\frac{12\rho(1-\nu^2)}{E}}$$

- d = thickness of the partition
- $\rho$  = density of the partition material
- E = Young's modulus
- $\nu$  = Poisson's coefficient

For frequencies above the critical one, airborne sound insulation can be calculated by the expression.

$$f < f_c$$

$$R = 20 \log(m'f) + 10 \log \eta + 10 \log \frac{f}{f_c} - 44$$

- $m'$  = mass of the partition per unit of area
- $\eta$  = loss factor of the partition

**Airborne noise insulation of double partitions**

A double partition is constituted by two simple partitions separated by a space, either filled with absorbent material or not. To increase the insulation between two enclosures without increasing the mass by much, one of the procedures consists of dividing the partition into two sheets separated by a distance.

When the sound waves of the emitting enclosure impinge on the first sheet, it is excited and transmits a vibration to the air located in the cavity between sheets, which then impinges on the second sheet, and this in turn transmits sound energy to the receiving enclosure. The factors to be taken into account in the airborne sound insulation of double partitions are the critical frequencies of the sheets and the resonance frequency of the system. The two sheets may not have the same critical frequency. In this case, the critical frequency band will have a significant insulation defect.

A double partition with air in the cavity behaves like a mechanical mass-spring-mass system. The system has a resonance frequency when the waves strike perpendicular to the partition. They are obtained by the expression:

$$f_{rs} = 600 \sqrt{\frac{1}{d} \left( \frac{1}{m'_1} + \frac{1}{m'_2} \right)}$$

- d = separation between the sheets in centimetres
- $m'_1$  and  $m'_2$  = surface masses of the walls, [kg/m<sup>2</sup>]

When the waves randomly affect the resonance frequency, it is obtained by multiplying the previous value by 1.4.

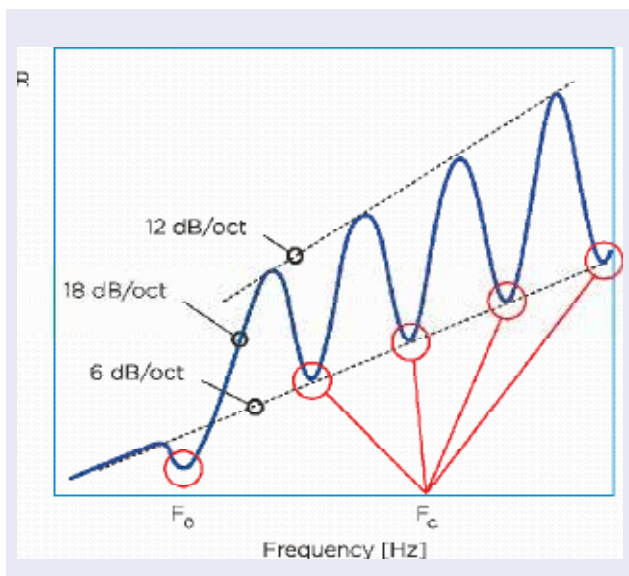
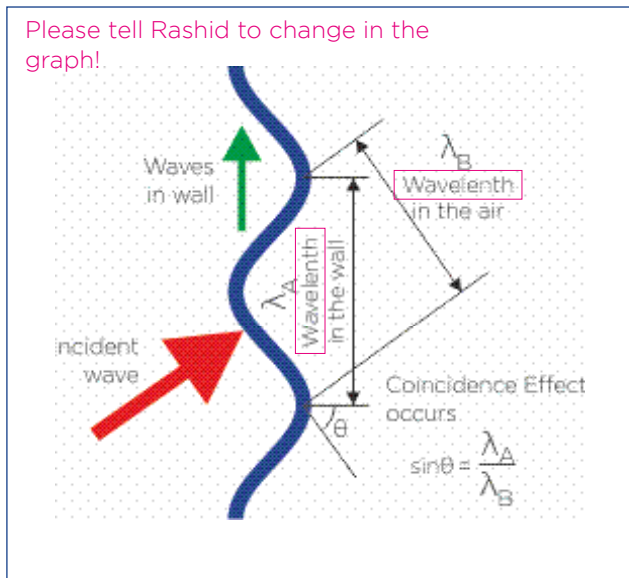

If the frequency of the incident sound is greater than the system's resonance frequency, the insulation of the double partition is better than that of a simple partition of the same mass. In practice, the system's resonance frequency must be below 80 Hz.

**Resonance frequencies of the cavity**

In the air chamber between the two sheets, the sound waves propagate and reflect on the internal faces, and stationary waves are formed. At the resonance frequencies of the sound pressure in the cavity, more sound increases and is transmitted through the sheets of the partition, and the insulation of the partition presents a minimum of insulation.

For flat waves propagating in a normal direction towards the partition, the resonance frequency of the cavity is obtained by the expression:

$$d = n \frac{\lambda}{2}; \lambda = \frac{2d}{n}$$

$$f = \frac{c}{\lambda} = \frac{cn}{2d} = \frac{170n}{d}$$

n = 1, 2, 3..., d in metres. In general, only the resonance frequencies of the cavity for n = 1 and 2 are detrimental to the insulation of the double wall. The resonance frequencies of the cavity will need to be able to exceed 4,000 Hz.

**Influence of placing absorbent material in the cavity**

Placing absorbent material in the cavity modifies the acoustic coupling between the two sheets of the partition. The absorbent material is more rigid than the air and the resonance frequency of the system is greater. The absorbent material in the cavity eliminates the resonance frequency of the cavity and increases the airborne noise insulation of the double partition.

**Airborne noise insulation of mixed partitions**

Typically, the partitions of the enclosures are composed of different construction elements, characterised by different airborne sound insulation. For example, an acoustic cabin with a door and an acoustic viewer. The overall airborne sound insulation of the mixed partition can be estimated from the following expression:

$$R_g = -10 \log \frac{\sum_i S_i 10^{-0.1R_i}}{\sum_i S_i}, \text{ dB}$$

S<sub>i</sub> = area of the constructive element, [m<sup>2</sup>]  
 R<sub>i</sub> = airborne sound insulation of the constructive element i

A particular case of a mixed partition is a wall with a window, with areas S<sub>c</sub> and S<sub>v</sub>, insulations R<sub>c</sub> and R<sub>v</sub>, respectively, and the total area being S<sub>t</sub> = S<sub>c</sub> + S<sub>v</sub>. The overall mixed insulation would be:

$$R_g = -10 \log \left[ \left( \frac{S_v}{S_t} \right) 10^{-0.1R_v} + \left( \frac{S_c}{S_t} \right) 10^{-0.1R_c} \right], \text{ dB}$$

If we consider that β is the ratio between the area of the window and the total area, the insulation to overall air noise of the mixed partition would be:

$$\beta = \frac{S_v}{S_t}; R_g = -10 \log [\beta 10^{-0.1R_v} + (1 - \beta) 10^{-0.1R_c}]$$

It can be verified that the airborne sound insulation of the mixed partition is conditioned by the airborne sound insulation of the window, and is a maximum of 10 dB greater than the insulation of the window.

### 3. Noise control

#### 3.1. Principles of noise control

With the most recent technological progress in the field of safety and hygiene in the workplace, designing an industrial facility without taking into account adequate acoustic attenuation solutions is inconceivable. The design of such solutions is based on the sound insulation and attenuation concepts already described above. Below, all noise control systems will be analysed in relation to the practical solution of the problems of high noise levels, pointing out the general principles that support the designer in adopting a specific type of solution.

In this sense, the recommendations of ISO 11690 "Acoustics: Recommended practice for the design of workplaces with low noise levels that contain machinery" can be used. This standard is divided into three sections:

1. Noise control strategies. ISO 11690-1.
2. Noise control measures. ISO 11690-2.
3. Propagation of sound and prediction of noise in work premises. ISO 11690-3.

The noise control measures can be applied at the source, in the transmission route and in the reception area. The following schematic graphic represents this aspect, which also indicates the type of applicable solutions.

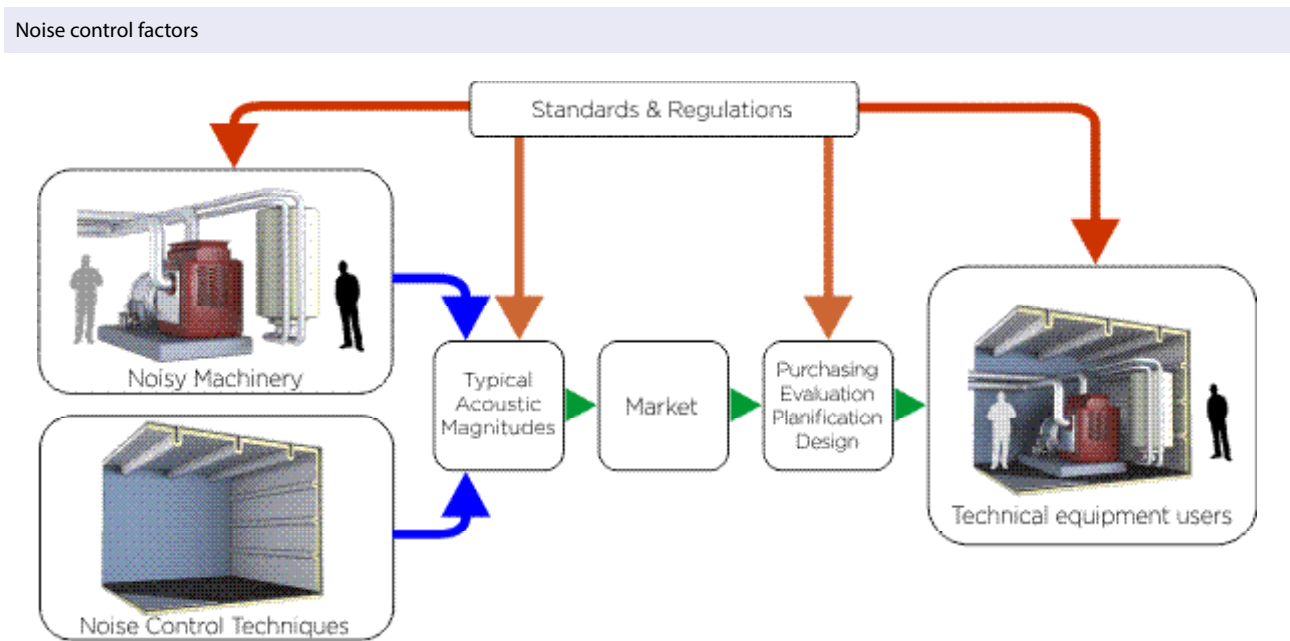

Noise control in industry			
Noise control at the source	Noise control in the propagation path		Noise control at the receiver
Selection and use of processes of work with low noise levels	Source location	Insulation of vibrations	Personal cabins
	Enclosures	Floating floors	Noise barriers
	Silencers	Construction of joints in building elements	Hearings protector devices
Selection and use of machinery with low noise level	Absorbent treatments		Limitation of noise exposure
	Noise barriers		
	Walls, partitions		

### 3.1.1. Noise control at the source

The measures described in this section refer to the reduction of the noise generated by the processes and machines in operation. They should be implemented at the design stage, since retroactive measures can affect operational requirements and are generally more expensive. The control of noise at the source in workplaces particularly addresses the reduction of noise of existing machines, the development and selection of work processes with low noise and production technologies, the replacement of machine parts and the evaluation of the obtained results.

#### Noise control at the design source

When considering the noise produced by a machine, two types of noise generation must be distinguished:

- 1 The generation of dynamic noise (gas and/or liquid) and mechanical generation. Dynamic fluid noise arises from temporary fluctuations in the pressure and velocity of fluids. Examples include combustion processes, fans, exhaust openings and hydraulic systems.
- 2 Mechanically generated noise is caused by the vibrations of the machine components that are excited by the dynamic forces generated by impacts or off-balance masses. These vibrations are transmitted to other surfaces that radiate noise. Some examples of mechanical noise are gear wheels, electric motors, hammers, agitators and mechanical presses.

To control noise at the source, the noise generation mechanism must be taken into account.

Examples of reducing **fluid dynamic noise** are the following:

- a) Reduction of periodic pressure fluctuations in the excitation source.
- b) Reduction of flow rates.
- c) Avoidance of sudden changes in pressure.
- d) Efficient design of components to achieve a continuous flow.

Examples of reducing **mechanical noise** are the following:

- a) Reduction of exciting dynamic forces (for example, balancing with additional masses).
- b) Reduction of the vibration energy of the machine structure at the excitation point for a given dynamic force (example: by means of stiffeners or additional masses called inertial blocks).
- c) Reduction of the vibration transmission (sound transmitted by the structure) from the excitation point to the sound-emitting areas (example: by using elastic elements and materials with high internal damping or by using flexible joints for pipe connections).
- d) Reduction of the sound radiated by a vibrating surface (example: by using thin walls with ribs instead of thick and rigid walls, layers of cushioning in thin metal sheets, perforated metal sheets and whenever acoustic insulation is not required).
- e) Acoustic encapsulations or acoustic panel structures (example: acoustic enclosures or thin damped metal sheets near the radiant area).

#### Information on noise emitted by machinery

In addition to the existing information in the technical documentation on the noise emission of the machinery that is provided by the suppliers/manufacturers of the machinery, there may be other specific measures for the industrial sectors, which can be found in databases, professional journals, journals of business associations, etc.

For some families or types of machines, there are lists of data on noise emission values obtained under specific operating conditions. These lists can help buyers select machines and equipment with low noise emission. The information regarding the noise emissions that the machinery supplier must provide is shown in the different EC directives.

There are two main directives that deal with the standards that the machinery must comply with - Directive 98/37 from the point of view of safety and Directive 2000/14 from the point of view of environmental noise emission.

The former requires the machinery be designed and manufactured with consideration for minimising the emission of noise propagated by the air. In addition, the manuals of the machinery are required to orient the installation and assembly requirements towards reducing the noise level.

Likewise, it is mandatory to show the A-weighted equivalent continuous sound power level in the work areas when it exceeds 70 dB(A), the maximum value of the instantaneous C-weighted pressure level is greater than 130 dB, and the acoustic power level produced with a weighted equivalent sound pressure level A exceeds 85 dB(A) in the work areas.

Regarding the measurements, the directive states that the acoustic measurement will be carried out with the most appropriate procedure, informing the client of the operating conditions and the method used for the measurement. If the location of the work areas is not defined, the measurements will be carried out at a distance of 1 m from the area of the machine and at a distance of 1.6 m above the ground level or access platform.

Directive 2000/14 is much more exhaustive than the previous one and replaces a group of previous directives that were applied to machines located outdoors. This Directive stipulates "that the machines show the CE marking and the guaranteed acoustic power level information, and that they are accompanied by a CE declaration of conformity". The directive distinguishes between two types of machines – those whose level of sound power should not exceed a given limit (see the table below) and those that only have to show their level of sound power, without being limited. In this directive, administrative requirements are discussed for certification and valid measurement methods.

The acoustic power level  $L_w$  is used as a common parameter to characterise the noise, so the sound pressure levels from this power would need to be calculated in order to know the noise emitted at a certain distance.

Type of machine / equipment	Net installed power P in kW Electric power in kW Mass in kg Cutting width L in cm	Permissible sound Power level in dB	
		Stage I as from 03.01.2002	Stage II as from 03.01.2006
Compaction machines (vibration rollers, vibratory plates, vibratory rammers)	$P \leq 8$	108	105
	$8 < P \leq 70$	109	106
	$P > 70$	$89 + 11 \log P$	$86 + 11 \log P$
Tracked dozers, tracked loaders, tracked excavator loaders	$P \leq 55$	106	103
	$P > 55$	$87 + 11 \log P$	$84 + 11 \log P$
	$P \geq 55$	104	101
Wheeled dozers, wheeled loaders, wheeled excavator loaders, dumpers, graders, loader-type landfill compactors, combustion-engine driven counterbalanced lift trucks, mobile cranes, compaction machines (non-vibrating rollers), pavement-finishers, hydraulic power packs	$P > 55$	$85 + 11 \log P$	$82 + 11 \log P$
Excavators, builders hoists for transport of goods, construction winches, motor hoes	$P \leq 55$	96	93
	$P > 55$	$83 + 11 \log P$	$80 + 11 \log P$
Hand-held concrete brakers and picks	$m \leq 55$	107	105
	$15 < m < 30$	$94 + 11 \log m$	$92 + 11 \log m$
	$m \geq 30$	$96 + 11 \log m$	$94 + 11 \log m$
Tower cranes		$98 + \log P$	$96 + \log P$
Welding and power generators	$P_{el} \leq 2$	$97 + \log P_{el}$	$95 + \log P_{el}$
	$2 < P_{el} \leq 10$	$98 + \log P_{el}$	$96 + \log P_{el}$
	$P_{el} > 10$	$97 + \log P_{el}$	$95 + \log P_{el}$
Compressors	$P \leq 55$	99	97
	$P > 55$	$97 + 2 \log P$	$95 + 2 \log P$
	$L \leq 50$	96	94
	$50 < L \leq 70$	100	98
	$70 < L \leq 120$	100	98
	$L > 120$	105	103

### 3.1.2. Noise control in the propagation path

The most effective solutions for reducing the noise emitted by machines, installations, pipes, etc. as noise control systems in the propagation path include absorbent treatments, acoustic enclosures, silencers, acoustic screens, vibration isolation systems and active control systems, among others.

The effectiveness of noise control measures through the use of enclosures, silencers or screens can be measured and evaluated by measuring insertion loss, loss of transmission and the reduction of sound level (see ISO 11690-1: 1990, EN ISO 15665, ISO 7235, ISO 11691, ISO 15667, ISO 11957, ISO 17624, EN 14388 and others).

### 3.1.3. Noise control at the receiver

To perform noise control actions in the receiver, it is necessary to first know the noise exposure limits in the studied area and promote action such as installing acoustic enclosures (personal protection cabins) or the use of hearing protection.

### Noise exposure limit

Directive 86/188 / EEC, transferred to the legislation of each EU country, sets the limits for workers' exposure to noise, measured by the level of daily exposure (LEP, d.). Workers are often exposed to different levels of noise during their daily work. This originates from different equivalent sound levels depending on the exposure time and the existing sound levels in each work area. In this case, the daily exposure is calculated by adding (logarithmic sum) the different equivalent levels.

The directive shows the use of management systems for reducing noise exposure. An example that is very useful for all industries is the study of noise exposure figures (dB(A) / part-time). This makes it possible to:

- Establish the influence of each different sound source on the total exposure to worker noise.
- Make decisions regarding the interest of attenuating or reducing the sound levels of a source according to its influence on the total exposure to worker noise.
- Determine "good practices" during work performance (very often, it is possible to work away from the source of noise if the worker has been informed about this possibility).
- Optimise the use of hearing protectors. Sometimes it is difficult to use them for the whole task (that is, for 8 hours). It is easier to use them only during the time when tasks are performed in very noisy areas.

The most frequent noise control systems in the receiver are personal protection cabins and individual protection such as hearing protection.

### 3.2. Absorbent treatments

Optimised location of the machines in an enclosure can provide a substantial reduction in the noise level in the work areas. This is applicable when designing new plants and facilities, but it must also be considered for existing plants when new machinery is to be incorporated, or more suitable distribution of the existing one is made in order to reduce sound levels. A reduction in noise can be obtained by increasing the distance between the noise sources and the work areas. The relationship between the noise emission of the machine and the noise level in the study area is determined by the sound propagation characteristics. The propagation of the sound and, therefore, the acoustic qualities of a room are influenced by the treatment of the surfaces (ceiling and walls) with materials that absorb the sound which should be selected in relation to the frequency spectrum of the noise. The attenuation obtained by the use of absorbent materials depends highly on the thickness. The noise in a given area is composed of direct noise from the source and noise reflected from the enclosure's solid surfaces (floor, walls, ceilings, other equipment, accessories, etc.).

The absorbent treatments on the solid surfaces exclusively reduce the reflected noise. It is possible to evaluate the acoustic quality of an enclosure and, therefore, the effectiveness of a surface treatment using the expressions of reduction of sound pressure levels as a function of the absorption of the boundary walls.

In general, industrial noise is in the frequency range of between 500 Hz and 2,000 Hz. In such situations, the following reductions in the acoustic pressure level must be achieved in relation to enclosures with hard walls and ceilings:

- In areas close to the sound source, the reduction of the A-weighted sound pressure level is in the range of 1 dB to 3 dB because the surface treatment is not very effective when it is close to the field near the source.
- In areas far from the sound source, this reduction is usually between 3 dB and 8 dB.
- In areas far from the sound source, this reduction can usually be between 5 dB and 12 dB, depending on the room dimensions and the extent of treatment of the wall, ceiling or suspended absorbent elements.

The combination of surface treatment and acoustic barriers is usually quite effective and leads to a reduction in the noise level which is substantially higher than that obtained with only one of these measures. In addition to noise reduction, which can be measured objectively, there will be a significant subjective improvement.

The noise reduction can be estimated for some simple and useful cases, such as a machine or work area near a wall or a corner. In the case of a machine near a corner or wall, the following equations can help predict the sound level following treatment. This is valid when you do not need to take into account more machines or surfaces.

#### Wall (near a machine or work area)

In the case of a machine near a corner or wall, the following equations can help predict the sound level following treatment. This is valid when there are no other machines in the area or nearby reflective surfaces. The typical case is a machine near a wall with work areas that are further away. The following figure shows how sound reduction can be obtained by using an absorbent lining of the wall (in this case,  $b$  = machine-wall distance,  $a$  = workplace distance - wall,  $l$  = length of the lining on the wall):

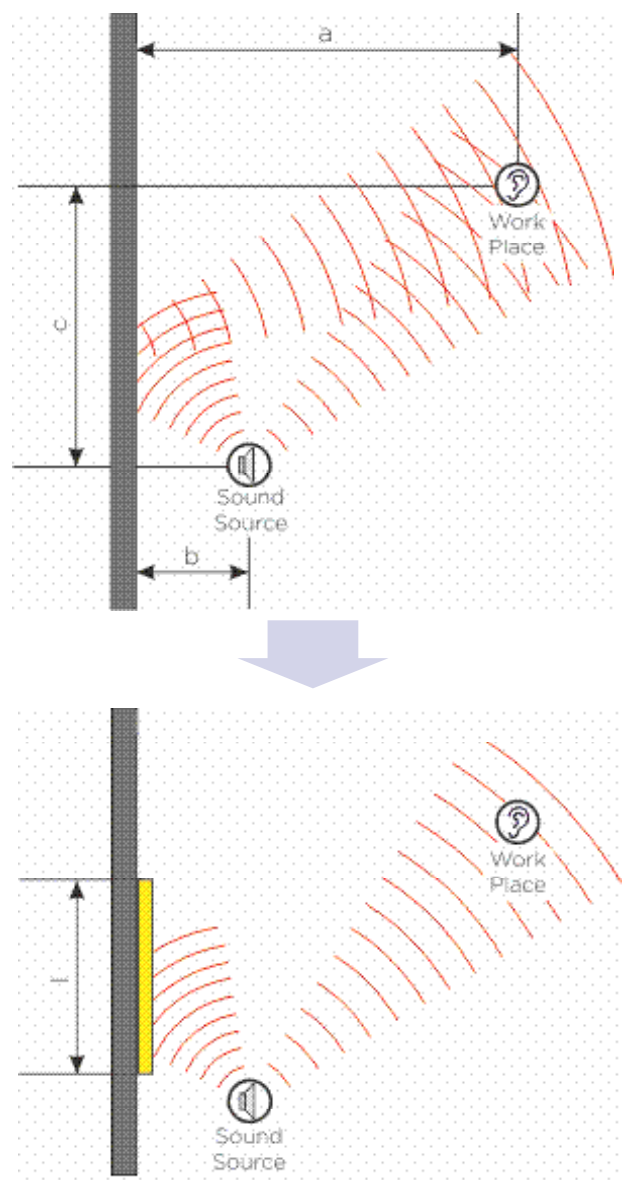

For this case, a reduction in the noise level in the work area results in a material having the absorption coefficient  $\alpha_w$  according to the following equation:

$$\Delta L = 3 - 10 \cdot \log (2 - \alpha_w)$$

The same applies when the workplace is close to the wall.  
 $b$  = machine - wall distance  
 $a$  = workplace distance - wall  
 $l$  = length of the lining on the wall

**Corner (near a machine or work area)**

The following situation is quite common (machine in the corner of an enclosure with reflection and work area at a greater distance).

$a_1, a_2$  = distances from the machine  
 $b_1, b_2$  = distances from the workplace  
 $c_1, c_2$  = distances as in the figure

For this case, a reduction in the noise level in the work area results in a material having the absorption coefficient  $\alpha_w$  according to the following equation:

$$\Delta L = 6 - 20 \cdot \log (2 - \alpha_w)$$

The calculation also applies when the workplace is closer to the corner than the machine.

$a_1, a_2$  = distances from the workplace  
 $b_1, b_2$  = distances from the machine  
 $c_1, c_2$  = distances as in the figure

In these cases, the following equations can be applied to determine the  $\alpha_w$  for the 4 previous cases:

$$\alpha_w = \frac{\sum_f \alpha_f \cdot 10^{0.1L_f}}{\sum_f 10^{0.1L_f}} \quad l = \frac{a \cdot c}{a + b} + k$$

where  $L_f$  is the sound pressure level in dB(A) at 1 m distance from the work area, in octaves or thirds of octaves,  $\alpha_f$  is the absorption coefficient of the absorbing material in the frequency band.

$k$  is calculated from  $k \geq 170/f_u$ , where  $f_u$  [Hz] is the lowest frequency that influences the total sound pressure level A of the noise spectrum. In most cases,  $k = 1$  [m].

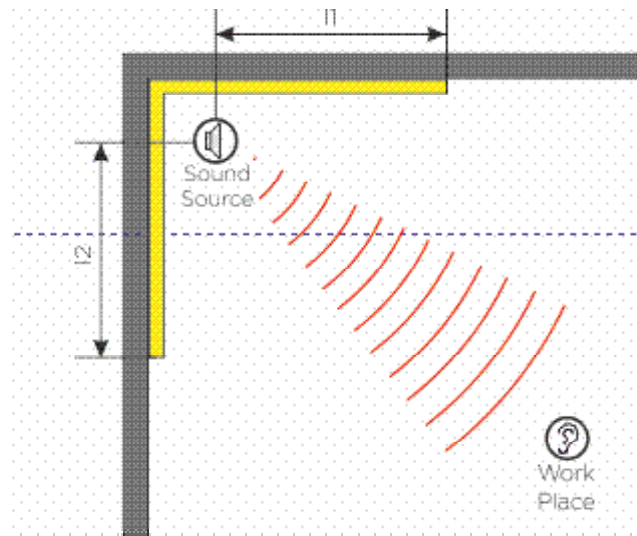
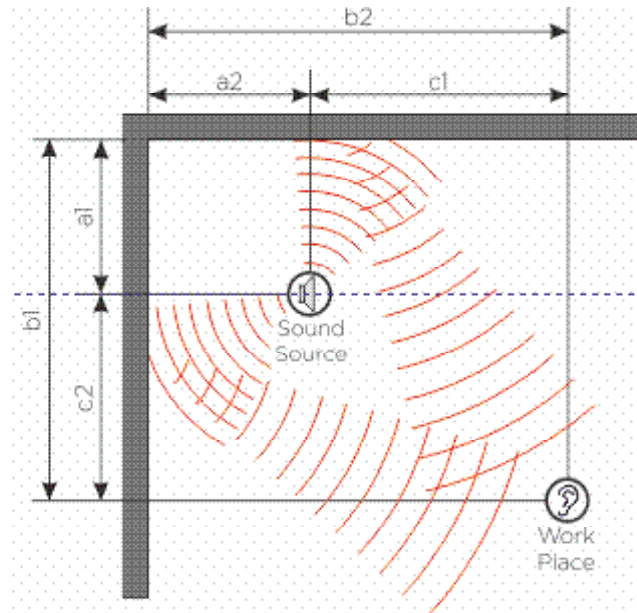

### Absorbent treatments in industrial enclosures

For industrial enclosures where there are work areas where several sound sources are taken into account and absorbent treatments can be installed on both walls and ceilings, and there is also the possibility of installing absorbent panels suspended from the ceiling, it is possible to estimate the sound reduction by reducing the existing reverberation. Bear in mind that this noise reduction will be at the maximum in the vicinity of the walls or absorbent ceilings and at the minimum close to the source.

The efficiency achieved in the level reduction can be calculated with the expression indicated below:

$$\Delta L = 10 \log \frac{A}{A_0}$$

where:

$A_0$  = equivalent absorption area before treatment

$A$  = equivalent absorption area after treatment

$$A = \frac{S_1 \cdot \alpha_m}{1 - \alpha_m}$$

...

$$\alpha_m = \frac{\alpha_1 \cdot S_1 + \alpha_2 \cdot S_2 + \dots + \alpha_n \cdot S_n}{S_1 + S_2 + \dots + S_n}$$

$A$  = absorbing area of the room, [m<sup>2</sup>]

$S$  = sum of the surfaces that limit the room, [m<sup>2</sup>]

$\alpha_m$  = average absorption coefficient of the surfaces that limit the enclosure

$S_1, S_2, \dots, S_n$  = surfaces that limit the enclosure, [m<sup>2</sup>]

$\alpha_1, \alpha_2, \dots, \alpha_n$  = absorption coefficient of the different surfaces that limit the enclosure

### 3.3. Noise in ducts

A typical way of transmitting airborne noise is through air conditioning systems and ventilation ducts, as well as the systems for the aspiration and expulsion of air in cabins or acoustic enclosures.

The most frequent sound damping solutions make use of acoustic absorption techniques or silencers. A conduit of sufficient length with respect to its section can attenuate the sound inside it according to the following empirical expression:

$$\Delta L = 1.05 \cdot \alpha^{1.4} \cdot \frac{P}{S} \quad [\text{dB/m}]$$

where:

$L$  = sound reduction per length unit of the duct

$\alpha$  = absorption coefficient of the interior material of the duct in -Sabine

$P$  = Inside perimeter of the conduit, [m]

$S$  = Inside section of the conduit, [m<sup>2</sup>]

We can see that the higher the value of  $\alpha$ , the greater the acoustic attenuation obtained. The use of conduits of the Climaver family, with remarkable absorption coefficient values, will have excellent results in sound reduction. The same will happen in metallic ducts lined with mineral wool-type absorbers. The geometry of the duct is decisive for the attenuation; ducts of relatively small dimensions will have high P/S ratios. Conversely, large ducts will have low P/S ratios, with a decrease in acoustic attenuation.

A particular case of noise in conduits and noise control in them is that of acoustic silencers and will be discussed later.

### 3.4. Acoustic enclosures

In the case of high noise levels in industrial facilities that create problems with safety and hygiene (risk of hearing loss) or worker comfort, the installation of acoustic enclosures, personal protection cabinets or acoustic screens and barriers are some of the most effective solutions.

As a general observation, a single recommendation on the most appropriate solution, from the three types of solutions indicated above, cannot be made. This decision will depend exclusively on the circumstances in each case, considering the productive aspect as well as any other circumstance.

For this reason, to choose between the different acoustic attenuation solutions, the following factors must be taken into account – acoustic attenuation, economic considerations, thermal stress, machinery maintenance, accessibility, productivity, safety, lighting, influence of other external physical effects.

Therefore, the type of acoustic attenuation solution most used and recommended from the industrial point of view is that of acoustic enclosures with removable sound attenuating panels of the "sandwich" type. In fact, the "sandwich panel" concept makes it possible to change the composition of the panel to obtain the precise acoustic attenuation property required.

Since the panels are removable, they offer some desirable characteristics for normal operation of the machinery: visibility (using acoustic glass viewers), accessibility and maintenance (since they are removable), etc. When we refer to a removable enclosure, it usually means that the entire façade can be removed. In more technically developed panel systems, the disassembly of each panel unit is possible, facilitating implicit operation. If it is necessary to dismantle the acoustic panels for maintenance needs of the machinery interior, it is possible to install acoustic enclosures with fixed panels, with an access door and an interior corridor around the machinery for maintenance.

The cabins or enclosures must have their own ventilation, with adequate access doors, acoustic viewers to see inside and any other requirements such as wiring entry or pipe penetrations. This equipment must guarantee correct functioning of the installation or of the existing machinery in its interior. If some parts of the enclosure are in contact with the machinery, it is important to install anti-vibration treatments and the correct sealing of the penetrations or sealing elements and joints.



1. Inlet/outlet ventilation
2. Acoustic window
3. Inlet/outlet pipe/cable penetrations
4. Access acoustic door
5. Acoustic panel
6. Removable panel for maintenance

EN ISO 15667: 2000 "Acoustics – Guidelines for the control of noise by means of enclosures and cabinets" refers to the performance of enclosures and cabins for noise control. It describes the acoustic and operational requirements that have to be agreed between the supplier or the manufacturer and the user of these enclosures and cabins.

- a) Cabins or enclosures to protect the operators from noise: insulated cabins fixed to machines (for example, vehicles, cranes).
- b) Cabins that cover or house machines: enclosures with an acoustically untreated open area fraction of less than 10 % of the total area are the main object of this international standard.

In the EN ISO 15667 standard, emphasis is placed on lightweight constructions. However, thicker and larger structures, such as civil works walls such as brick or concrete are not excluded.

The enclosures or cabins with more than 10 % of open and untreated area belong to the category of partial enclosures. They can be considered more as screens than enclosures.

One way of evaluating the effectiveness of an acoustic enclosure is to use the insertion loss  $D_e$  which is defined and can be calculated as follows:

$$D_{e \text{ enclosure}} = \Delta L_{w \text{ enclosure}} = L_{w \text{ engine without enclosure}} - L_{w \text{ engine with enclosure}}$$

$$L_{w \text{ engine with enclosure}} = L_{w \text{ engine without enclosure}} + 10 \log\left(\frac{4}{A}\right) - R + 10 \log S$$

A = equivalent absorption area of the enclosure lining, [m<sup>2</sup>]

R = acoustic reduction/insulation of the enclosure's acoustic panel, [dB]

S = surface of the enclosure, [m<sup>2</sup>]

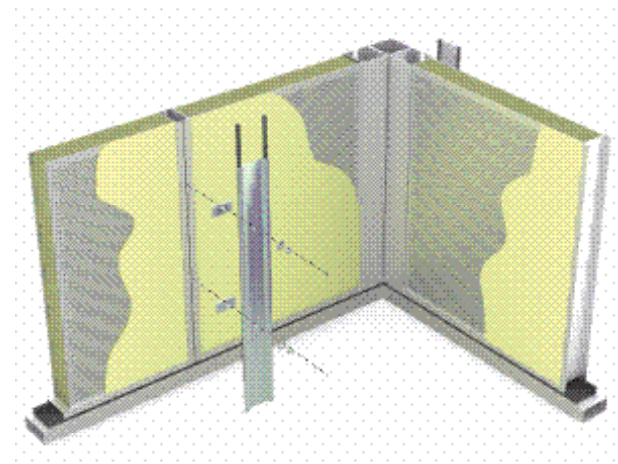

It is essential to cover the internal surface of the enclosure with sound absorbing material. A common finish for sandwich panels, used in industry, is a perforated sheet (percentage of perforation exceeding 33 %) that covers a layer of highly absorbent material, such as ISOVER mineral wool products. The density of the mineral wool has a minimum influence on the sound insulation performance of the acoustic panel.

Special attention must be paid to the vibration control produced by the machinery. In fact, it is common for the machine to generate high levels of vibration, which are transmitted to the acoustic enclosure, causing an additional source of noise and, therefore, reducing its real properties of noise reduction. The acoustic panels that form the acoustic enclosure are "light" structures in comparison with the machinery, acting as radiating panels of the noise originated by the vibrations. For this reason, rigid connections of these panels with machinery should be avoided, and in some cases should be designed with adequate damping characteristics to absorb structural noise.

As indicated in the following figure, it is necessary to reduce the openings of the acoustic enclosure to a minimum to ensure the real effectiveness of the acoustic enclosure. In this respect, it is necessary to draw attention to the need to use properly designed silencers in the ventilation openings, as well as the acoustic viewers and doors, when necessary. These additional elements must have at least the same acoustic insulation as the acoustic panels that form the enclosure.

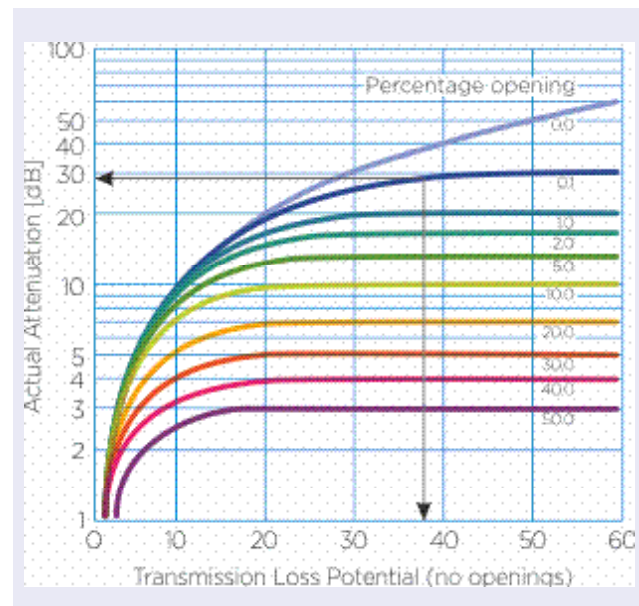

Most acoustic enclosures of machinery need a ventilation system to be able to dissipate and ventilate the heat produced in its interior and thus prevent the machines from overheating. Natural ventilation or forced ventilation systems can be installed, depending on the interior heat extraction requirements. It should be taken into account that in the forced ventilation installation, the sound pressure levels produced by the fans should be considered as an additional source of noise inside the enclosure.

With partial enclosures, the combination of all parameters, which are normally handled in these acoustic enclosure constructions, together with the special influence of the geometry, the environment and the open surfaces, makes it very difficult to establish a method that can predict the sound attenuation that will be obtained, specifically when we contemplate more open surfaces.

ISO 11957 gives the rules to determine the acoustic insulation of the cabins through on-site measurements. The term suggested by this standard is acoustic insulation ( $D_p$ ), in octaves or thirds of an octave, obtained as:

$$D_p = (L_p)_{\text{room}} - (L_p)_{\text{cabin}}$$

$L_p$  = average of the sound pressure, in the room and in the cabin, [dB]

Knowing the level of sound power of the machinery, and knowing the acoustic insulation of the  $D_p$  cabin, you can determine the sound pressure level outside using the following expressions:

$$L_p = L_w + 10 \log \left( \frac{q}{4\pi r^2} + \frac{1}{R} \right)$$

$$R = \frac{S\alpha}{1-\alpha}$$

$$D_p = L_{\text{int}} - L_{\text{ext}}$$

R = constant of the room

The interior sound pressure level would be initially calculated from the acoustic power data, Q, and R constant of the room, to then calculate the  $L_{\text{ext}}$  using the insulation data of the enclosure under consideration.



### 3.5. Acoustic screens

In many cases, an obstacle called a barrier or acoustic screen is placed to reduce the noise in the propagation path. The placement of acoustic barriers or screens of a sufficient density (minimum of 20 kg/m<sup>2</sup>) can generate energy losses in the path of propagation between the source and an observer. The value of these losses is not usually high (less than 20 dB). The calculation of acoustic screens is based on Fresnel diffraction theories and on experimental data. Approximate acceptable values can be obtained from the attached Maekawa chart. The graph shows that the acoustic attenuation offered by the barriers depends on the dimensionless number N, which relates the difference in the path

that the sound must travel between emitter (E) and receiver (R) before and after placing the barrier and the wavelength of the sound with the various frequencies. As usual in acoustics, high frequencies are attenuated more easily than low frequencies. A distinction can be made between the types of barriers or acoustic screens: infinite and finite barriers.

#### Infinite barriers

In this case, the barrier does not have to be physically infinite; acoustically the term infinite barrier means that the lateral contributions are negligible, that is to say, that the ends are far enough away from both the sound source and the receiver so that they make no contribution.

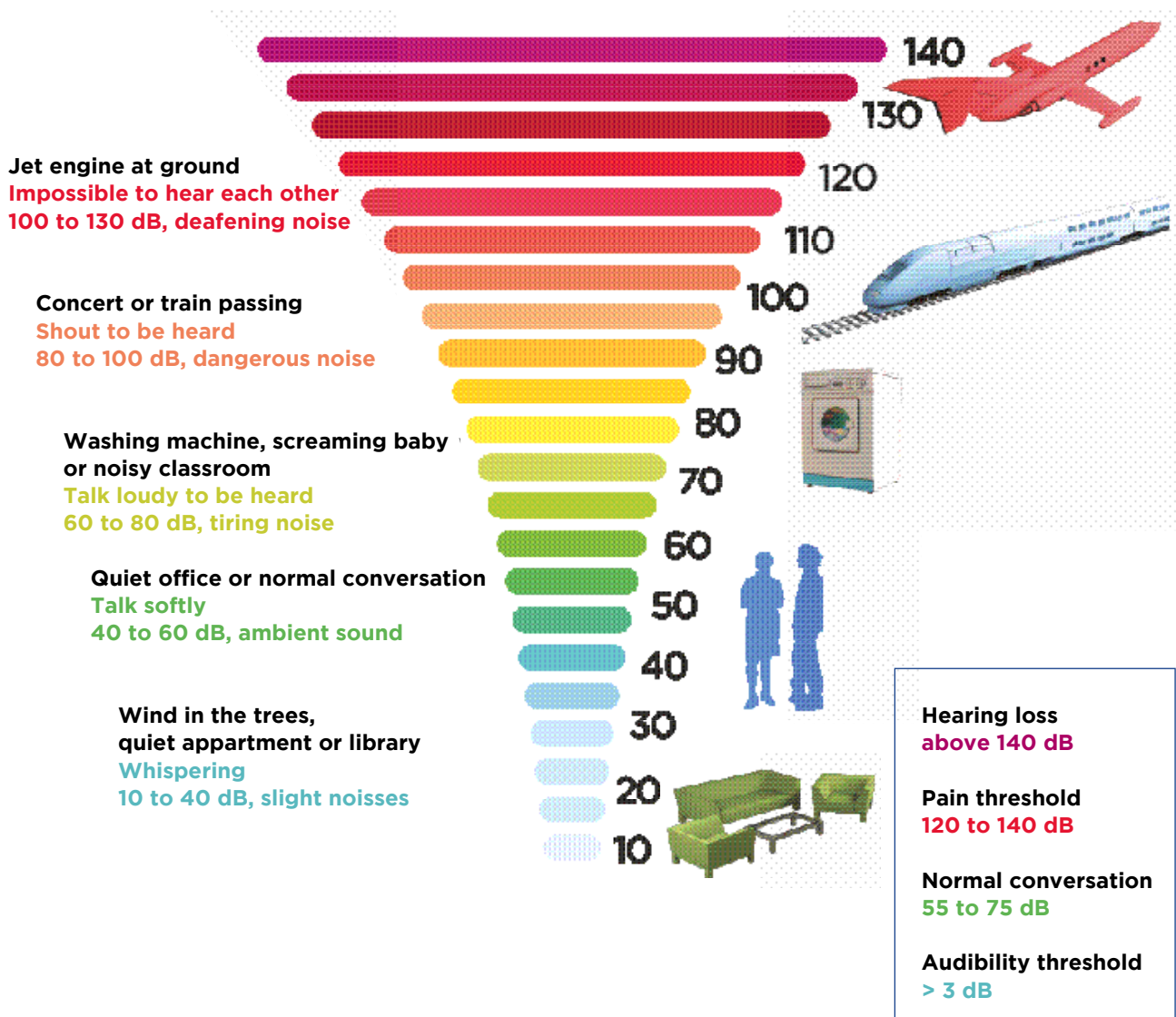

In this case, and always for point sources, the attenuation produced by a barrier is given by the Kurze approach:

$$\Delta L = 20 \log \frac{\sqrt{2\pi N}}{\tanh \sqrt{2\pi N}} + 5 \quad N \geq -0.2$$

$$\Delta L = 0 \quad N < -0.2$$

N = Fresnel number

$$N = \pm \frac{2}{\lambda} (A + B - d)$$

$$\delta = (A + B - d)$$

= wavelength of the sound

d = straight path between source and observer

A + B = path travelled by saving the barrier between source and observer, + if the observer is in the shadow zone and - if the observer is in the area of light

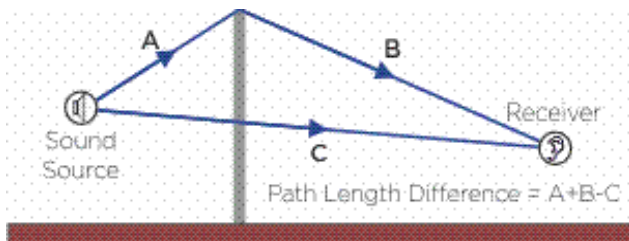

In the light area  $N < -0.2$ , the attenuation can be assumed as negligible, while in the transition zone to the shadow zone, the attenuation can be assumed to be from 0 to 5 dB. In the shadow zone, the attenuation can oscillate within a range of values between 5 dB and 24 dB. This practical limit is the result of a large number of experiments.

In addition to this formulation, there are others applicable; among these, we present the one which enables the simplest calculation of the attenuation using:

$$\Delta L = 10 \log \left( \frac{1}{\frac{\lambda}{3\lambda + 20\delta}} \right) \quad \lambda = \frac{c}{f}$$

= wavelength

= difference of paths between the direct and the diffracted

If the frequency  $f$  is used instead of the wavelength the ratio between them is given by the speed of sound  $c$ .

### Finite barriers

In this case, each of the barrier edges diffracts the sound that is, the sides must also be considered. In this case the attenuation of the barrier can be calculated by:

$$\Delta L = 10 \log \left[ \frac{1}{\sum_{i=1}^n \frac{\lambda}{3\lambda + 20\delta_i}} \right]$$

N = number of faces that contribute to the sound level in the receiver

= wavelength

$\delta_i$  = difference of paths between the direct and the diffracted

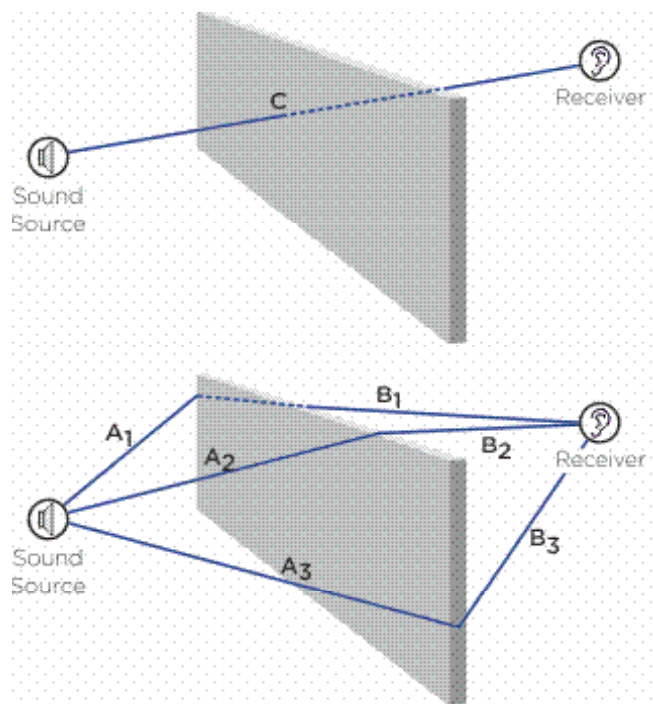

Path length difference =  $A_1 + B_1 - C$   
 =  $A_2 + B_2 - C$   
 =  $A_3 + B_3 - C$

## 3.6. Silencers

### 3.6.1. Definitions

---

#### Definition of silencer

Device that reduces the transmission of sound through a duct, a pipe or an opening without preventing transport of the fluid inside. See EN ISO 14163 "Acoustics-Guidelines for controlling noise using silencers".

---

#### Absorbent silencer

A silencer that provides broadband acoustic attenuation with a relatively low pressure loss by partially converting acoustic energy to heat through friction in porous or fibrous duct linings.

---

#### Reactive silencer

General term for reflective silencers or resonators where most of the attenuation does not involve the dissipation of acoustic energy.

---

#### Reflective silencer

Silencer that provides for single or multiple sound reflections due to changes in the cross-section of the duct, duct linings with resonators or branches to duct sections with different lengths.

---

#### Resonator silencer

Silencer that provides acoustic attenuation to weakly damped resonances of the elements. Note: The elements may or may not contain absorbent material.

---

#### Discharge silencer

Silencer used in the steam purge and pressure release lines that throttle the gas flow by a considerable pressure loss in porous material and that provide sound attenuation by decreasing the flow velocity at the outlet and reacting to the sound source.

---

#### Active silencer

Silencer that provides for the reduction of sound through interference effects by means of sound generated by controlled auxiliary sound sources.

---

#### Passive adaptive silencer

Silencer with passive sound attenuation elements dynamically adjusted to the sound field.

---

#### Loss of insertion $D_i$

Difference between the levels of sound that propagate through a conduit or an opening with and without a silencer. The loss of insertion is expressed in decibels [dB]. Adapted from ISO 7235.

---



---

#### Difference of insertion sound pressure level $D_{ip}$

Difference between the sound pressure levels that occur in a point of immission, without a significant level of unusual sound, with and without a silencer installed. The difference in insertion sound pressure level is expressed in decibels [dB]. Adapted from ISO 11820.

---

#### Loss of transmission $D_t$

Difference between the levels of incident acoustic pressure and transmitted through the silencer. The loss of transmission is expressed in decibels [dB]. For standard test laboratories,  $D_t$  is equal to  $D_i$ , while the results for  $D_t$  and  $D_i$  obtained from on-site measurements can often differ due to limited measurement possibilities.

---

#### Attenuation of discontinuity $D_s$

The part of the insertion loss of a silencer or section of a silencer due to discontinuities. The attenuation of discontinuity is expressed in decibels [dB].

---

#### Loss of propagation $D_a$

Decrease in the level of acoustic pressure per unit of length that occurs in the middle section of a silencer with constant cross-section and uniform longitudinal design, characterising the longitudinal attenuation of the fundamental mode. The loss of propagation is expressed in decibels per metre [dB/m].

---

#### Loss of exit reflection $D_m$

Difference between the level of incident acoustic pressure on and transmitted through the open end of a conduit. Note: The loss of exit reflection is expressed in decibels [dB].

---

#### Modes

Spatial distributions (or transient stationary wave patterns) of the sound field in a conduit that occur independently of each other and suffer a different attenuation. The fundamental mode is less attenuated. In narrow, absorbent ducts, higher modes have greater attenuation.

---

#### Cut-off frequency

Lower frequency limit for the propagation of a higher mode in a rigid wall conduit. The cut-off frequency is expressed in hertz [Hz].

---

*Note 1: In a circular section duct, the cut-off frequency for the first higher mode is  $f_c C = 0.57 c / C$ , where  $c$  is the speed of sound and  $C$  is the diameter of the duct. In a rectangular duct with a greater dimension  $H$ ,  $f_c H = 0.5 c / H$*

---

### 3.6.2. Types of silencers, selection and general principles

The selection of the silencers is determined by:

- the necessary reduction in the sound level
- the permissible loss of pressure in the gas flow
- the flow of noise caused by the silencer
- the space that is available for the silencer
- the necessary durability of the silencer when subjected to flow, pressure pulsations, mechanical vibrations, heat, contamination, humidity and corrosion
- inspection and cleaning possibilities

The silencers can be sub-divided into:

- absorption silencers
- reactive silencers, including resonators and reflective silencers
- discharge silencers

### 3.6.3. Absorption silencers

These silencers allow the attenuation of broadband sound by converting sound energy into heat at a relatively low pressure loss. If absorption silencers are used in ducts for gases with dusty contaminations or for gases that tend to cause fouling, precautions should be taken to avoid clogging or film formation on the surface of the absorbent material.

A simple absorption silencer is a straight duct with sound absorbing lining, a circular or rectangular section and without any accessories. To achieve high attenuation, the absorption area of the wall lining should be as large as possible. This is achieved by providing a large wall surface and large values of the acoustic absorption coefficient.

A high acoustic absorption coefficient is only possible when the thickness of the lining is at least one-eighth the length of the sound wave. This criterion can be met in simple absorption silencers, even for low frequencies, if a large enough cross-section is available where the silencer is to be installed. When large cross-sectional areas are to be covered, deflecting silencers with several deflectors are often used with the respective number of narrow segment conduits with rectangular cross-sections. Arrangements such as this will also suppress the beam formation that limits attenuation at higher frequencies and that occurs when the distance between the walls exceeds half the wavelength of the sound.

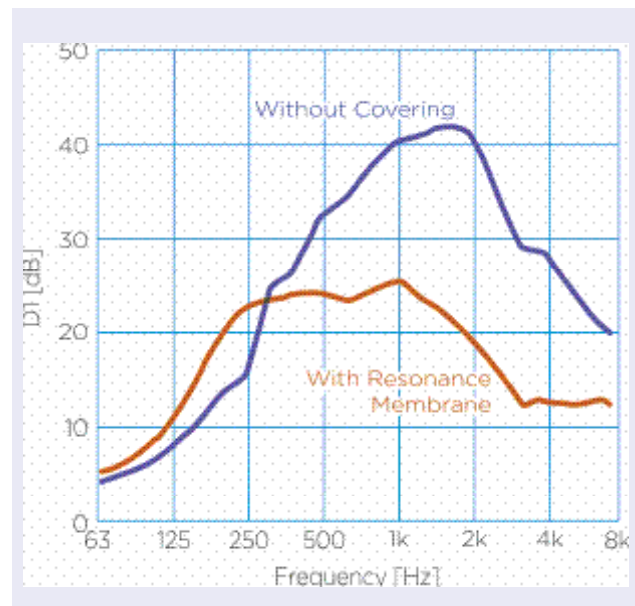
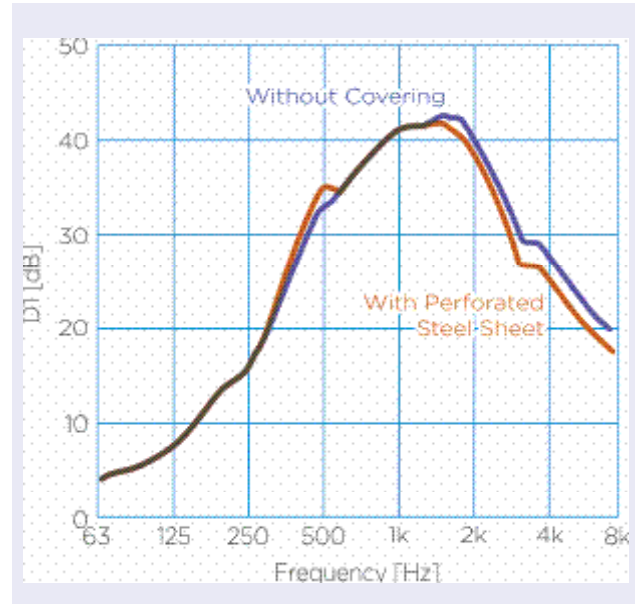

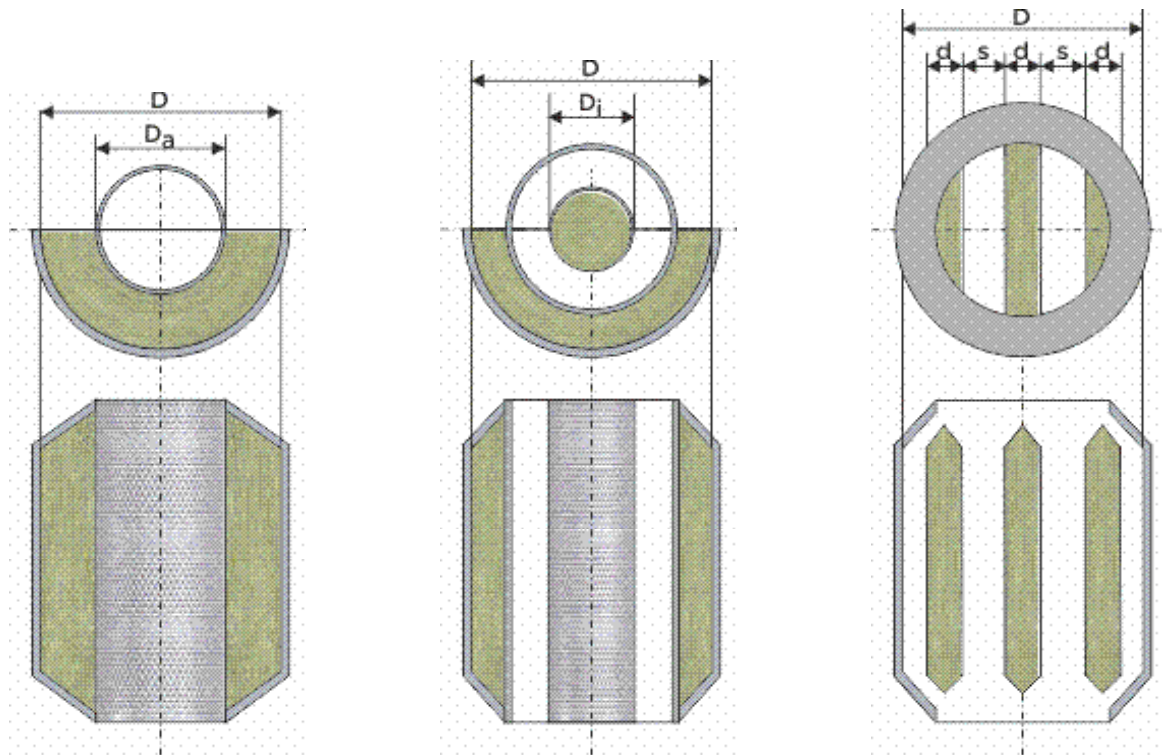

The absorbent wall linings and deflectors consist of one or more layers of absorbent material and a sound-permeable cover. Mineral wool is mainly used as absorbent material.

To cover the mineral wool absorbent materials, perforated sheet steel, stretched sheet steel or similar is used. For conditions of moderate stress, the use of mineral wool is common practice.

An absorbent material is characterised by its flow resistivity  $r$ , which varies between  $5 \text{ kPa}\cdot\text{s}/\text{m}^2$  and  $\text{kPa}\cdot\text{s}/\text{m}^2$ ; when it is higher, the fibres are thinner and the pores of the material smaller.

The acoustic properties that determine the degree of attenuation depend on the magnitude and distribution of the flow resistivity in the absorber and the mass per unit of area of the absorbent material's cover. In the case of broadband absorbers, the total flow resistance must not significantly exceed  $1 \text{ kNs}/\text{m}^3$ , and the cover must have an area mass that is markedly less than  $0.1 \text{ kg}/\text{m}^2$ . This is achieved by using perforated thin sheet, with the proportion of the area of perforations being 33 % or more. To increase absorption at low frequencies at the expense of high frequency attenuation, they are covered with heavier covering material.

### 3.6.4. Reactive silencers

#### Resonator silencers

Single resonators are mounted as junctions in ducts walls. Resonator groups are mounted into ducts as duct linings or baffles. Thus, they cause a limited pressure drop. The resonances are especially adjusted to low and mean frequencies which have to be attenuated. The efficiency is limited to a narrow frequency band; it is sensitive to touching flow and can (in certain unfavourable conditions) be negative so that a tone will be generated.

#### Reflective silencers

These silencers reduce the conversion of gas pulsations and gas vibrations into sound energy. Due to their rigidity they are normally chosen for fields of application where pure absorptive silencers are less appropriate and where larger pressure losses are permissible. This applies e.g. to gas flows with dust, higher flow velocities and higher pressure pulsations and in fields with strong mechanical vibrations. Maximum values of the acoustic insulation will be affected in their height and frequency range by the flow. Possibly, only a slight or even a negative acoustic insulation arises in some frequency bands.

### 3.6.5. Discharge or blow-off silencers

These act by reaction to the sound source, e.g. a valve, as well as by reducing the discharge velocity due to an enlarged surface. Nevertheless, the conversion of sound into heat is normally of slight importance. High pressure losses require a high mechanical strength of the silencer. The efficiency may be affected by substances which are carried along with the gas. Besides, there is the danger of ice formation.



### 3.6.6. Calculations

#### Losses of transmission of an absorption silencer.

The following calculation is a rough estimate, but it has been proven in practice. There is great reliability between the measurements and the most accurate - but expensive - calculations even in the frequency ranges that are often the most critical.

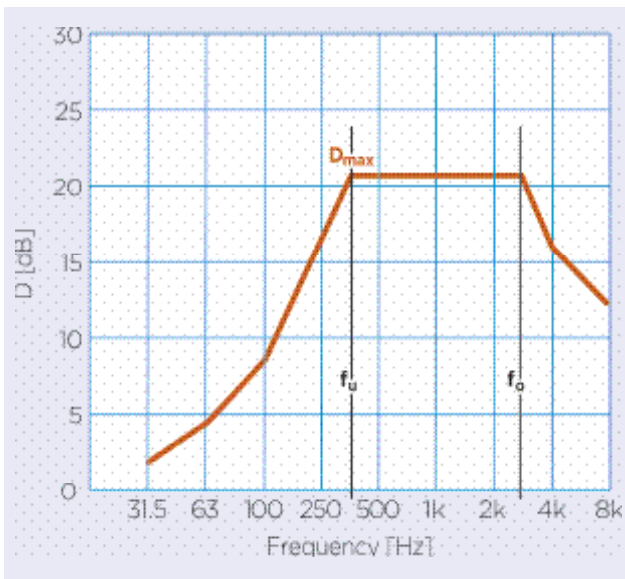

So

$$D_c = L_{w \text{ without}} - (L_{w \text{ with}} + L_{w \text{ flow noise}})$$

- $D_e$  = insertion loss, [dB]
- $L_{w \text{ without}}$  = level of acoustic power without a silencer
- $L_{w \text{ with}}$  = level of power with a silencer
- $L_{w \text{ flow noise}}$  = level of acoustic power generated by the flow of fluid

Let  $D_{max}$  be the maximum insertion loss in dB between the frequencies  $f_u$  and  $f_o$ , where  $D_{max}$  is according to the expression:

$$D_{max} = 1,5 \cdot \alpha \cdot \frac{P}{S} \cdot l$$

- $\alpha$  = absorption coefficient (1 in the range of  $D_{max}$ )
- $P$  = perimeter in the section
- $S$  = surface of the section
- $l$  = length of the baffles

The frequency  $f_u$  is determined by the width of the backdrops, and  $f_o$  by the passage of air:

$$f_u = \frac{c}{3 \cdot d} \qquad f_o = \frac{c}{s}$$

$$c = \sqrt{\frac{K P_{stat}}{\rho_{Med}}}$$

- $c$  = sound velocity in the medium, [m/s]
- $d$  = thickness of the backdrops, [m]
- $s$  = width of the air passage, [m]
- $K$  = adiabatic exponent
- $P_{stat}$  = static pressure, [N/m<sup>2</sup>]
- $\rho_{Med}$  = density of the medium, [kg/m<sup>3</sup>]

The insertion losses below  $f_u$  depend on the absorption of the material and can be determined by:

$$\text{If } f_m \geq 250 \text{ Hz, then } D(f_m) = 0.6 \cdot D(f_m + 1)$$

$$\text{If } f_m < 250 \text{ Hz, then } D(f_m) = 0.5 \cdot D(f_m + 1)$$

The losses above  $f_o$  result from:

$$D(f_m) = 0.7 \cdot D(f_m - 1)$$

- $D(f_m)$  = losses
- $f_m$  = centre frequency of the octave band

These calculations are valid for absorption silencers with an absorbent material lining, that is, mineral wool backdrops with a density of 80 kg/m<sup>3</sup> to 100 kg/m<sup>3</sup>.

The condition

$$\frac{\theta d}{\rho c}$$

must be between 2 and 6, while the temperature dependence of the specific flow resistance has to be considered. Also, for reasons of strength, the transverse barriers should be mounted every 500 to 700 mm. The retaining layer should not be too heavy and should have good sound transparency.

If protective covers are installed, they should be perforated sheets with a perforation surface above 33 %. If they are protected with a veil or foil, the attenuations at high frequency will vary depending on the thickness of the lining and its surface density. See the figure.

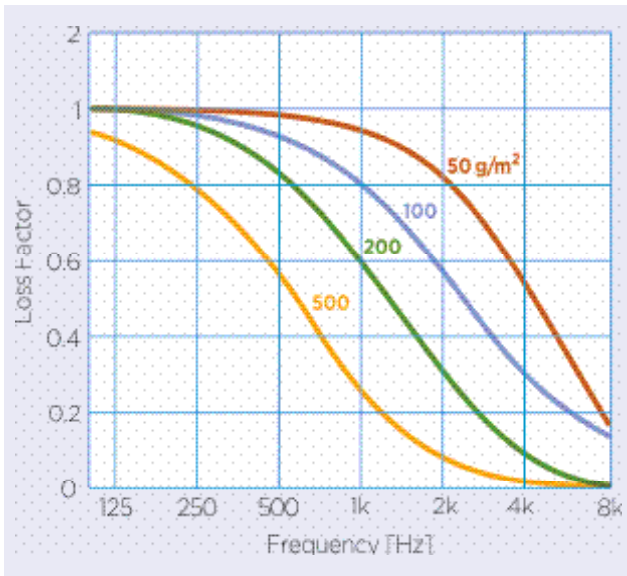

$$\alpha_{\text{cover}} = \alpha \cdot \text{loss factor}$$

$$D_{\text{cover}} = D \cdot \text{loss factor}$$

If there are high fluid flow velocities in the silencer, there is a deterioration, respectively, in the attenuation improvement that depends on the flow direction (in or against the direction of sound propagation). This influence on attenuation especially refers to the medium and high frequency range. Due to the flanking transmissions, maximum attenuations of more than 40 dB cannot be achieved without taking additional measures in the area of the silencer covering/tank. The higher values should not be applied and transmitted even though they result from the calculation. If higher attenuation values are required, silencers can be installed in series, leaving a large distance between them (at least 4 times the hydraulic diameter of the silencer section), placing aerodynamic tips at the silencer inlet and outlet, or placing the baffles staggered as in the attached figure.

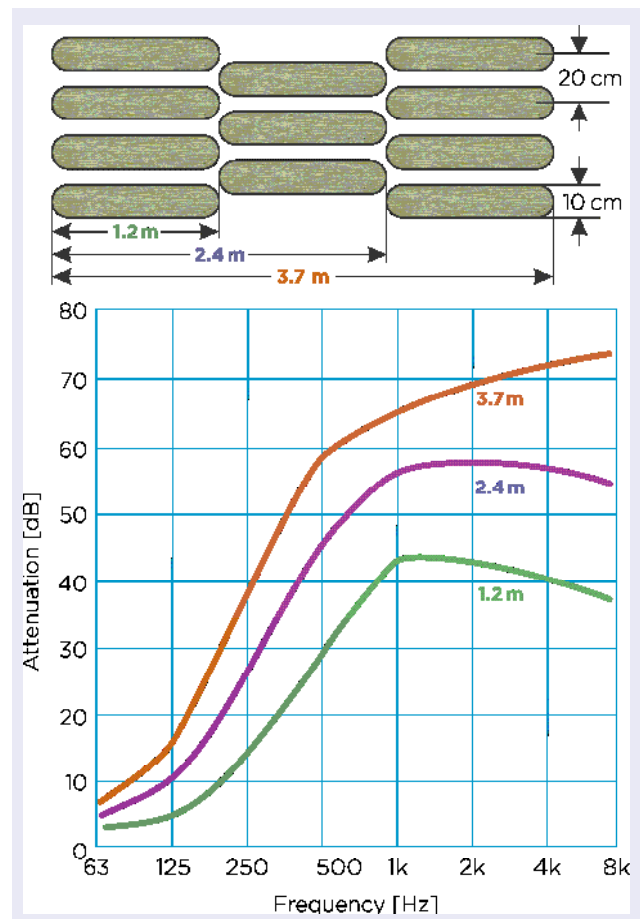
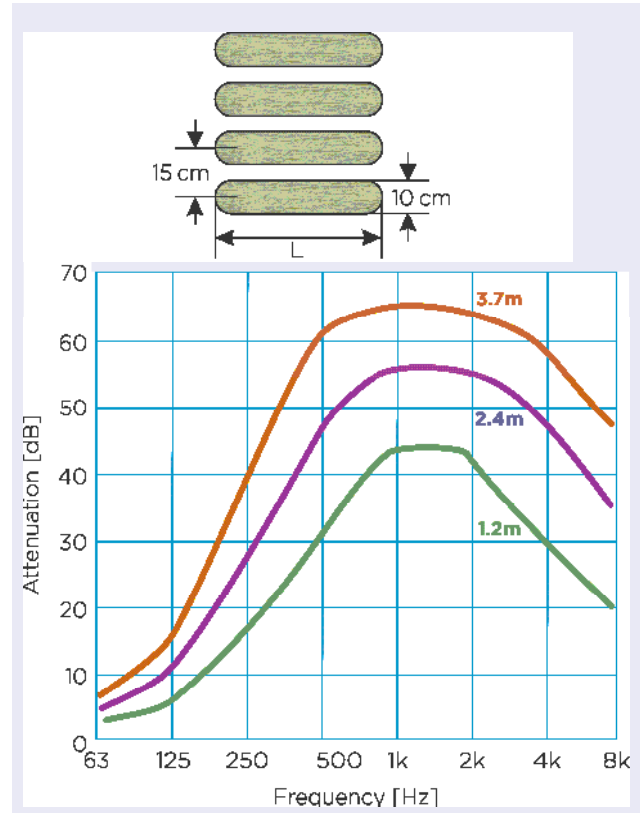

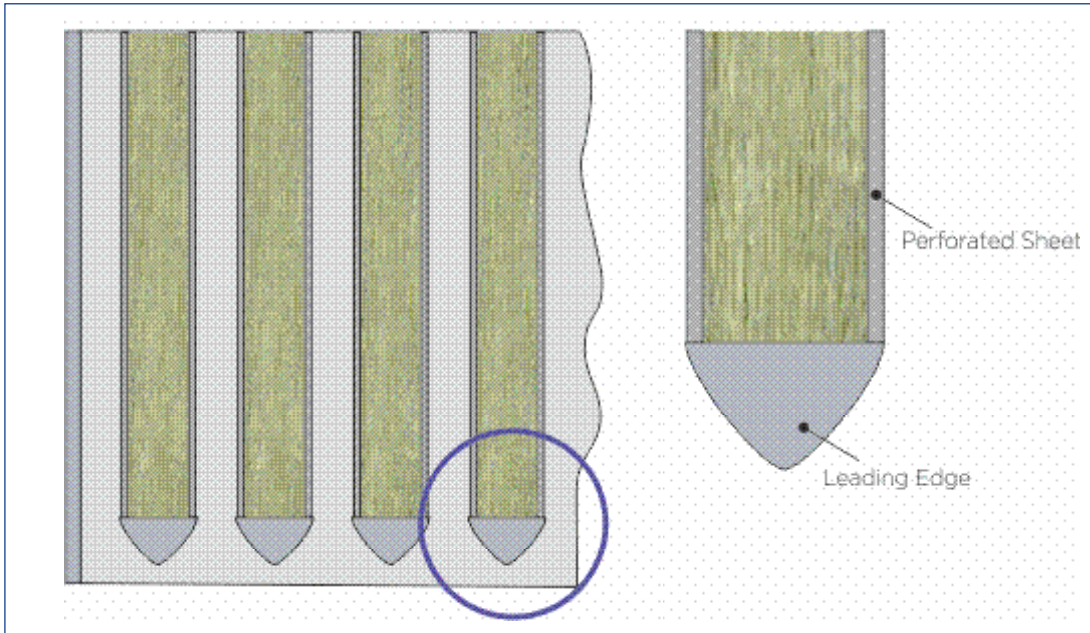

In addition to the acoustic requirements, other important things must be considered for the flow, such as the average speed ( $V_{\max}$  for deflectors without perforated sheet plate coating at about 10 m/s, with perforated sheet plate coating at about 25 m/s), flow noises and loss of pressure.

In addition, special attention must be paid to the pressure and temperature of the medium, for example, exhaust gas silencers with high fluid temperatures.

### 3.6.7. Regenerated noise or flow noise

The acoustic power level of the regenerated noise or flow noise can be estimated with the following expression:

$$L_{w,oct} = B + \left[ 10 \log \frac{\rho c S}{W_0} + 60 \log M_a + 10 \log \left( 1 + \left( \frac{c}{2f_m H} \right)^2 \right) - 10 \log \left( 1 + \frac{\delta f_m}{c} \right) \right]$$

B = value that depends on the type of silencer and the frequency, [dB]

v = flow velocity in the narrowest cross-section of the silencer, [m/s]

c = speed of sound within the medium, [m/s]

$M_a$  = Mach number ( $Ma = v/c$ )

p = static pressure, [Pa]

S = area of the narrowest cross-section, [m<sup>2</sup>]

f = average frequency of octave, [Hz]

H = maximum transverse dimension of the duct, [m]

= length scale that characterises the spectral component of the flow noise, [m]

$W_0 = 1 W$

For deflector silencers with smooth walls for air conditioning equipment, it is approximately  $B = 58 \text{ dB}$  and  $\delta = 0.02 \text{ m}$ .

### 3.6.8. Pressure losses

The total pressure loss of a silencer is decisive for selecting baffles (its width measurement) and the width of the air passage. There are pressure losses at the ends in front of and behind the baffles, as well as along the air passages between the baffles.

The pressure loss can be estimated using the following expressions:

$$\Delta P_i = (\zeta_s + \zeta_f) \frac{\rho}{2} v_1^2 = \zeta \frac{\rho}{2} v_1^2$$

$$\zeta_s = \left(\frac{d}{2}\right)^2 \left[0.5\zeta_1 \left(\frac{s}{d} + 1\right) + \zeta_2\right]$$

$$\zeta_f = 0.025 \frac{l}{s} \left(1 + \frac{d}{s}\right)^2$$

- $\zeta_1$  = drag coefficient of the side in front of the deflectors, for the rectangular deflectors  $\zeta_1 = 1$ , for deflectors with semi-circular air flow profiles  $\zeta_1 = 0.1$
- $\zeta_2$  = drag coefficient of the side behind the deflectors, for rectangular deflectors  $\zeta_2 = 1$ , for deflectors with semi-circular air flow profiles  $\zeta_2 = 0.7$
- $s$  = width of the space, [m<sup>2</sup>]
- $d$  = thickness of the deflector, [m]

Additional losses such as pressure losses of reduction or adaptation parts must be taken into account.

### 3.7. Vibration control

#### 3.7.1. Introduction

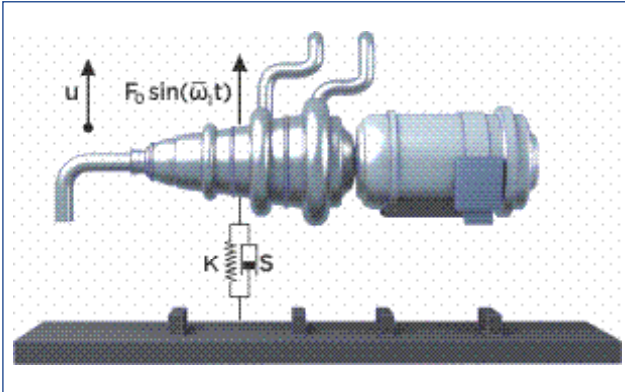

The system of the figure represents a damped harmonic forced oscillation as is the case we want to describe.

Equation in forces

$$M u''(t) + S u'(t) + k = F_0 \sin (\omega_1 t)$$

$\omega_1$  = forced frequency of harmonic excitation.

The above equation has a compound solution = specific solution + general solution

$$u (t) = u_g (t) + u_p (t)$$

The two addends have a very different significance and meaning:

The first represents a **transient component** of the response, which disappears over time as its amplitude extends exponentially to zero. (Peaks in start/stop of the motor).

$$u_g (t) = e^{-\nu \omega_1 t} (C \sin (\omega_1 t + \varphi))$$

(homogeneous solution)

The second summand, however, represents the **stationary response** and is much more interesting, because it is present as long as excitation is present.

$$u_p (t) = A \sin (\omega_1 t + \varphi)$$

(specific solution)

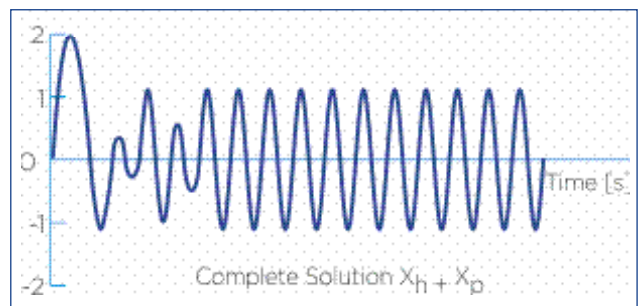
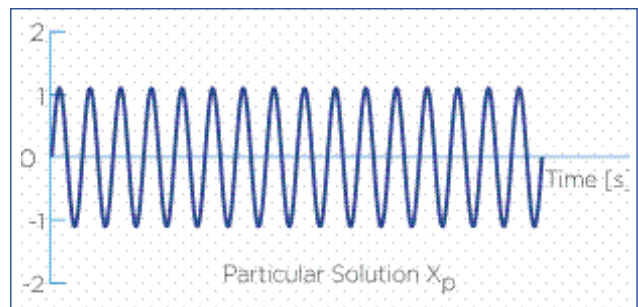
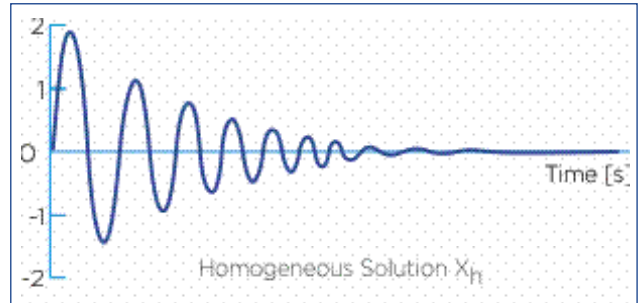

It is defined as natural or system-specific resonance frequency in a system without forced excitation and without damping:

$$\sqrt{k / m}$$

k = rigidity  
m = mass

And in case of damping (s), the damping ratio is defined as:

$$\nu = \frac{s}{2\sqrt{km}}$$

In practice, there is a large number of situations in which it is possible to reduce, but not eliminate, the dynamic forces (variables in time) that excite our mechanical system leading to the appearance of a problem of vibrations. In this respect, there are different methods or ways of presenting the **control of the vibrations**; among them, it is worth mentioning:

- a) The **knowledge** and control of the **natural frequencies** of the system in order to avoid the presence of resonances under the action of external excitations.
- b) The **introduction of damping** or any type of energy dissipating mechanism in order to prevent an excessive system response (high amplitude vibrations), even in the case of resonance.
- c) The use of vibration **insulating** elements that reduce the transmission of the excitation forces or the vibrations themselves between the different parts that make up our system.

### 3.7.2. Controlling the natural frequencies

It is known that when the excitation frequency coincides with one of the system's natural frequencies, a **resonance** phenomenon occurs. The most important characteristic of the resonance is that it causes large displacements by greatly amplifying the vibrations. In most mechanical systems, the presence of large displacements is an undesirable phenomenon since it causes the appearance of equally large strains and deformations that can cause mechanical failure.

Consequently, the resonance conditions must be avoided if possible in the design and construction of any mechanical system. However, in most cases, the excitation frequencies cannot be controlled when they are imposed by the functional requirements of the machine (for example, rotation speeds). In this case, the objective will be to control the system's natural frequencies in order to prevent resonances from arising.

The natural frequency of a system  $\omega_1$  can be changed by varying both the mass ( $m$ ) and the rigidity ( $k$ ) thereof. In many situations in practice, however, the mass is not easy to change, since its value is usually determined by the machine's functional requirements. Therefore, rigidity is the parameter that is more commonly modified when changing the natural frequencies of a mechanical system. Thus, for example, the rigidity of a rotor can be modified by changing the number and placement of the support points (bearings) or by installing a bank of inertia.

### 3.7.4. Insulation of vibrations: transmissibility

The procedure that makes it possible to reduce the undesirable effects associated with all vibration is known as vibration insulation.

Basically, this usually involves the introduction of an elastic element (insulation) between the vibrating mass and the source of vibration so that it is possible to reduce the magnitude of the system's dynamic response under certain conditions of excitation in vibration.

A vibration insulation system can be **active or passive**, depending on whether an external power source is needed or not in order to perform its function.

A **passive control** is formed by an elastic element (which incorporates a rigidity) and an energy dissipating element (which provides damping). Examples of passive insulators are a metal spring, a cork, a felt, a pneumatic spring, an elastomer, etc.



The so-called dynamic amplification factor (D) is the relationship between a system's vibration amplitude of one degree of freedom, subjected to a harmonic-type excitation and the static displacement (when the load is applied statically).

The value of D is:

$$D = \frac{1}{\sqrt{(1 - \alpha^2)^2 + (2v\alpha)^2}}$$

with  $v$  being, as is already known:

$$v = \frac{s}{2\sqrt{km}}$$

$\alpha = \omega_1$

$\omega_1$  = frequency of harmonic excitation / natural frequency of the system

The transmissibility  $T_r$  can be defined as the quotient between the amplitude of the transmitted force and that of the excitation force.

$$T_r = \frac{F_t}{f_{w1}} = D\sqrt{1 + (2v\alpha)^2}$$

The effectiveness of a vibration insulator is established in terms of its transmissibility. To be able to say that insulation has been achieved, the transmissibility must be < 1.

This requires that the excitation frequency  $\omega_1$  is, at least, four times the natural frequency of system  $\omega_n$ . It is advised that  $\omega_1 \geq 4 \omega_n$  for insulations > 90 %.

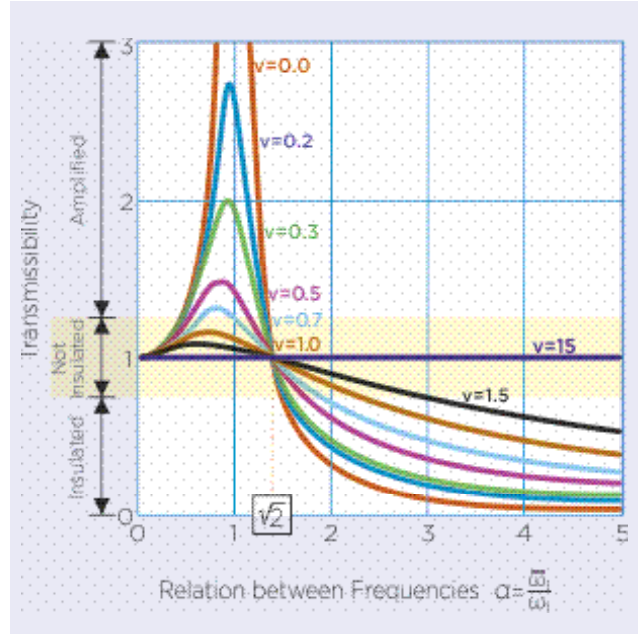

For values  $\alpha$  close to the unit, the system does not act as an insulator, but as an amplifier, transmitting forces or displacements much higher than the original ones. For a given excitation frequency  $\omega_1$ , the transmissibility value can be reduced by decreasing the natural frequency  $\omega_n$  of the system (which is equivalent to increasing  $v$ ). As far as the damping is concerned, the transmissibility can also be reduced by decreasing the damping ratio  $v$  since if  $\alpha > 1$ ,  $T_r$  decreases when  $v$  does so.

However, this approach is detrimental if the system is forced to undergo resonance, such as during start-up and shutdown situations. Therefore, in any case, a certain damping will always be necessary in order to prevent large amplitudes of vibration in the passage through the resonance.

### 3.7.5. Types of anti-vibration elements

Below, we refer to the characteristics and use of different types of insulating springs, with a brief description of their characteristics, field of application and behaviour.

#### Elastomer springs

Because of their elastic deformability and their small Young's modulus, elastomers are suitable materials for springs. They have greater damping than metal springs. The characteristics such as rigidity and damping depend on the selection of the basic material, the components of the materials mix, as well as the shape of the spring. They are also affected by environmental conditions such as temperature. Long-term ageing largely depends on the material's composition.

In elastomeric springs, static and dynamic rigidity are usually different, with dynamic rigidity being greater than the static rigidity. Only the natural frequencies of the insulated system, starting from the dynamic rigidity, should be calculated. When elastomeric springs are used, natural vertical frequencies of 6 Hz to 20 Hz can be obtained.

In general, the deformation curve under spring load is not linear. However, in practice, it can be made linear for the service load. For large and distributed compression loads, elastomeric springs in the form of plates or meshes are commonly used. For these applications, vertical natural frequencies are usually greater than 12 Hz.

#### Metal springs

The metal springs are not sensitive to large differences in temperature and are resistant to most organic substances. It is preferable to use metal springs made of steel for insulating machine vibrations. In steel springs, there is no difference between static and dynamic rigidity. When metal springs are used, natural vertical frequencies of 1.5 to 8 Hz can be obtained.

The steel springs are capable of storing large amounts of deformation energy with significant bending amplitudes. Their elastic characteristics do not vary over time. The compression coil spring is the metal spring that is generally used for the vibratory insulation of machines due to its largely linear deformation characteristics (deformation curve under load) and the wide selection of available rigidity levels.

#### Pneumatic springs

In principle, a pneumatic spring is constituted of a volume filled with gas with elastic walls. When the load varies, the spring is deformed at the level of the elastic walls, which causes a change in volume and, therefore, a change in pressure.

### 3.8. Noise in pipes

The document standard ISO 15665:2003 "Acoustic insulation for pipes, valves and flanges" defines the acoustic insulation performance of the systems to reduce the noise produced by pipes, valves and flanges in an installation. There are other standards like:

- NORSOK standard R-004 class 6,7 & 8
- ASTM E 1222
- CINI 9.2.02

The acoustic insulation assembly is identical to the thermal insulation of the pipes. We can conclude that all thermal insulation of pipes, valves and flanges has a certain degree of acoustic insulation. If we consider a bare pipe, the acoustic insulation system consists of:

- 1 Pipe
- 2 Porous layer
- 3 Optional: additional mass to increase sound insulation
- 4 exterior lining

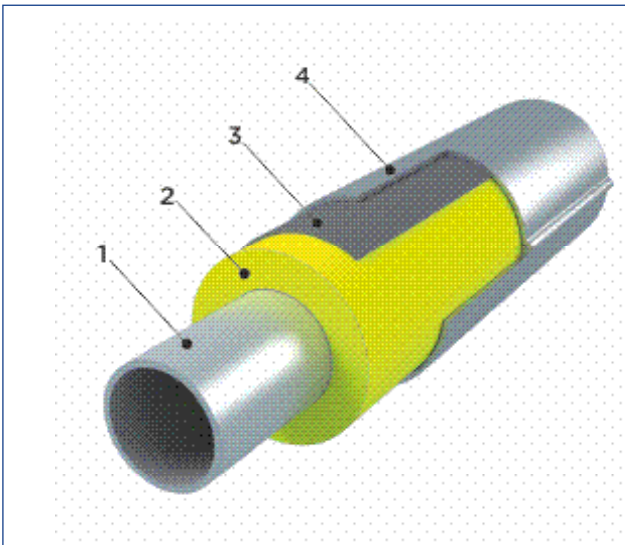

Acoustic insulation for pipes is usually made up of a metal outer layer or lining without rigid connections to the pipe. Acoustic losses must be avoided with the placement of counterbalanced layers and with well-made seals. A layer of porous material (mineral wool or open cell elastomeric foam) is placed between the outer layer and the pipe.

All standards make a difference in the acoustic performance of the systems using the magnitude lost by insertion and classifying using different kinds of insulation. As a rule, there are 3 classes: A, B and C. See Table 1 for examples of technical systems according to the classes.

General classes of pipe insulation			
Class	Thickness of porous layer [mm]	Minimum mass per unit area of cladding [kg/m <sup>2</sup> ]	Examples of standard metal sheet
A	50	2	0.7 mm aluminium
B	100	5	0.7 mm steel
C	100	10	1.3 mm steel

Insertion losses for pipe insulation according to classes								
Class	Insertion loss [dB]							
	Octave-band centre frequency [Hz]							
	63	125	250	500	1,000	2,000	4,000	8,000
A	--	--	--	5	10	15	20	20
B	--	--	5	10	20	25	30	30
C	--	5	10	15	25	30	35	35

Minimum insertion losses s/ISO 15665.								
Class	Range of nominal diameter D [mm]	Octave band centre frequency [Hz]						
		125	250	500	1,000	2,000	4,000	8,000
		Minimum insertion loss [dB]						
A1	D < 300	-4	-4	2	9	16	22	29
A2	300 ≤ D < 650	-4	-4	2	9	16	22	29
A3	650 ≤ D < 1,000	-4	2	7	13	19	24	30
B1	D < 300	-9	-3	3	11	19	27	35
B2	300 ≤ D < 650	-9	-3	6	15	24	33	42
B3	650 ≤ D < 1,000	-7	2	11	20	29	36	42
C1	D < 300	-5	-1	11	23	34	38	42
C2	300 ≤ D < 650	-7	4	14	24	34	38	42
C3	650 ≤ D < 1,000	1	9	17	26	34	38	42

The layer of porous material is an insulator of the vibration between the pipe, and the lining and it also absorbs the noise. The porous material can be in shell or blanket format. It must be remembered that the performance of the products must be adequate for the maximum operating temperatures and for the environment where they are installed.

The porous material must have the following features:

- Resistivity of air flow in the range of 25,000 to 75,000 Ns/m<sup>4</sup> (Ns/m<sup>4</sup> = Pas/m<sup>2</sup>)
- Rigidity less than 106 N/m<sup>3</sup>

Examples of suitable products for the porous material layer:

- Mineral wool (glass wool, stone wool and ULTIMATE)
- Flexible open cell elastomeric foam

Those products where the fibres are perpendicular to the pipe wall, such as the lamellae, can increase the rigidity and therefore reduce the performance of the proposed acoustic system.

### 3.9. Personal protection cabins

Personal protection cabins are considered as acoustic enclosures, but instead of attenuating noise and surrounding machinery, they are intended to surround and protect the receiver from noise – people/workers in this case. The sound pressure levels inside personal protection cabins, as well as the acoustic enclosures seen previously, mainly depend on the following factors:

- Sound reduction  $R$  of the acoustic panels, which depends on the composition of the sandwich panel.
- Effective surface of dividing walls.
- Absorption characteristics of the materials inside the personal protection cabin.

The walls and ceilings of the cabin must be homogeneous or with openings (glass viewers, doors, ventilation) properly treated to avoid losses. In practice, the sound reduction level which can be achieved by these means is from 5 dB(A) to 20 dB(A).

If the protection cabin is highly reflective, there will be a reverberation effect in the interior that generates an "additional" noise level inside the cabin, which, for practical purposes, will worsen the level of noise reduction. Therefore, it is necessary to install absorbent material inside. For this reason, the best solution is composed of a combination of panels in which the inner face of the enclosure is formed by a perforated protective sheet that covers the highly absorbent material (normally stone wool, protected by a glass fibre veil).

The level of acoustic pressure inside the acoustic enclosure can be calculated using the following equation:

$$L_{p(r)} = L_{p(s)} - R + 10 \log \frac{4S}{A}$$

$L_{p(r)}$  = sound pressure level in the receiver

$L_{p(s)}$  = sound pressure level of the source

$R$  = sound reduction of the panel, [dB]

$S$  = wall surface, [m<sup>2</sup>]

$A$  = equivalent absorption area of the receiver's room, [m<sup>2</sup>]

Some important elements of these personal protection cabins are the windows and doors. The sound reduction levels of the additional elements must be at least the same as the acoustic panels that form the personal protection cabins. It is important to pay special attention to the manufacturing system of the protection cabin, its installation, fixing and additional elements to avoid greater losses of noise because of these reasons.





### 3.10. Hearing protection

In most industrialised countries, there are regulations that indicate the limits of workers' exposure to noise in 3 zones or levels:

#### Exposure limit values

$L_{Aeq,d} > 87$  dB(A) and/or  $L_{peak} > 140$  dB(C)  
(When applying the limit values, the attenuation provided by the hearing protector will be taken into account)

#### Higher exposure values that give rise to action

$L_{Aeq,d} > 85$  dB(A) and/or  $L_{pico} > 137$  dB(C)

#### Lower exposure values that give rise to action

$L_{Aeq,d} > 80$  dB(A) and/or  $L_{pico} > 135$  dB(C)

Levels 2 and 3 require the use of hearing protection and level 1 recommends it, so the indications for using them as follows:

Workers should wear hearing protection if the noise or noise level in the workplace exceeds 85 decibels (A-weighted) or dB(A). In the area between 80 to 85 dB(A), hearing protection must be available in the workplace and its use recommended.

A full conservation program must be implemented when hearing protection is necessary. To implement a hearing conservation program, it will be necessary to incorporate noise assessment, hearing protection selection, employee training and education, audiometric testing, maintenance, inspection, record-keeping and program evaluation. If the hearing protection is removed only for a short period or does not fit properly, the protection is substantially reduced.

Select hearing protection that:

- Is for reducing sound levels at work. For more information, contact the agency responsible for occupational health and safety legislation in your country.
- Provides adequate protection. Follow the manufacturer's instructions.
- Is comfortable.

#### Types of hearing protectors

An earplug should be inserted to block the ear canal. There are two types: pre-formed or mouldable (foam plugs). Earplugs are sold as disposable products or as reusable earplugs.



Semi-inserted earplugs, consisting of two earplugs, held on the ends of the ear canal by a rigid band.

The earmuffs or headphones consist of sound-attenuating material and soft ear pads that fit around the ear and the hard outer cups. A ribbon holds them together.



Manufacturers provide information on the noise attenuation capacity of a hearing protector such as the SNR number (single number rating).

#### Custom-moulded earplug

This is a personal moulded earplug with a silicone rubber moulded and vented, which is tailor-made to an individual's concha bowl and ear canal providing full comfort. It is designed to be worn in any noisy environment. The custom-moulded earplugs can be worn comfortably with PPE, including, safety glasses, breathing apparatus and helmets, for example. Each pair is crafted especially to fit the individual's unique ears. These are the best ear plugs available, providing a perfect fit, superior comfort, accurate and reliable protection, and great durability. Professional lab custom-moulded ear plugs do require ear impressions. Values of SNR are available from the manufacturer.

#### Advantages and disadvantages of hearing protection devices

##### Earplugs

**Advantages:** Inexpensive. Applicable to all workers. Small and easy to carry. Can be used with personal protection equipment (can be used with ear protection). More comfortable with long-term use in hot and humid working environments. Convenient for use in closed spaces.

**Disadvantages:** Need more time for adaptation. More difficult to insert and remove. Need good hygiene practices. Can irritate the ear canal. Easy to replace. More difficult to see and control use. Make communication difficult. Become annoying after having worn them for a few hours (sweat, etc.).

##### Earmuffs or headphones

**Advantages:** Less variability of attenuation between different users. Designed to be adjusted to most sizes of head. Can be easily seen at a distance to help checking their use. Are not easily lost. Can be used with minor ear infections.

**Disadvantages:** Less portable and heavier. More inconvenient for use with other personal protection equipment. More uncomfortable in hot and humid working environments. More inconvenient for use in closed spaces. May interfere with the use of safety glasses or prescription glasses

**What is a Single Number Rating (SNR) and what is a Noise Reduction Rating (NRR)?**

**SNR** The SNR is a single number rating system determined according to International Standard ISO 4869. The tests are carried out by laboratories that are independent of the manufacturers. SNRs are expressed in dB and are used as a guide for comparing the potential noise reduction capability of different hearing protection devices.

SNR per device				
Device	Earplugs	Semi-insert earplugs	Earmuffs	Custom moulded earplug
SNR (dB)	21-39	14-35	22-36	14-26

**NRR** The NRR (Noise Reduction Rating) is a method which attempts to describe a hearing protector based on how much it reduces the overall noise level by the hearing protector. The NRR as a clinical evaluation theoretically provides an estimate of the protection of a given device. The reasons for rating each hearing protector involve OSHA and EPA requirements for product safety and reliability. The rating enables the end-user to assess the product’s attenuation abilities for noise in their own specific work environment.

Manufacturers provide information about the noise-reducing capability of a hearing protector as an NRR (noise reduction rating) number. The NRR is based on the attenuation of continuous noise and may not be an accurate indicator of the protection attainable against impulse noise and low frequency noise. The highest NRR rating for earplugs is 33, and the highest available NRR rating for earmuffs is 31. These values reflect the level of noise protection available for each device when worn alone. Combining earplugs with earmuffs can offer a NRR protection level of 36.

There is no direct conversion but a reasonably accurate guide is  $NRR + 2 \text{ or } 3 = SNR$ .  
 Example  $NRR 22 = 3 SNR 25$

**There are standards for hearing protectors ISO 4869-1: 1990.**

Acoustic – Hearing protectors – Part 1: Subjective method of measuring the attenuation of sound.

**ISO 4869-2: 1994.**

Acoustic – Hearing protectors – Part 2: Estimation of effective levels of A-weighted sound pressure when hearing protectors are used.

**ISO 4869-3: 2007.**

Acoustic – Hearing protectors – Part 3: Measurement of the insertion loss of earmuff protectors using an acoustic test accessory.

**3.11. Active noise control**

Given the current technology, systems are being researched and developed with the purpose of reducing the noise impact of machinery and equipment by means of active noise control methods.

The first noise control systems that were developed are the so-called “passives”. These methods do not respond in real time to the intensity of noise present since they have no way of knowing the existing sound level and adapting to its change, nor are they programmed to respond in a specific way to specific situations. These kinds of control are designed to reduce the noise in a pre-established environment, and they do so by reducing the vibration or excitation of the components that cause the noise disturbances.

**3.11.1. Principles of noise control**

Acoustic problems arising from the enormous growth of technology in the manufacture and design of engines, heavy machinery, high-speed pumps, fans and many other sources of noise, have gained much attention since exposure to high noise levels is harmful to humans from the physical and psychological aspect. The problem of controlling the level of noise in the environment has been the focus of a huge amount of research in recent years.

The classical approach to producing noise cancellation or reduction is a passive one. Techniques such as absorption and insulation are intrinsically stable and effective over a wide range of frequencies. However, these cancellation systems are usually large, expensive and generally ineffective in cancelling noise at lower frequencies. The efficiency of these systems is also limited to a fixed structure and can be very impractical for a number of situations where space is important and the volume of the installed system becomes an obstacle. The defects of passive noise reduction methods have given impetus to research and the use of other methods for controlling noise in the environment. During the last two decades, many investigations have been carried out in the field of Active Noise Control (ANC). The advantages of ANC lie in the effectiveness of low frequency noise reduction.

### Comparison between passive and active noise control methods.

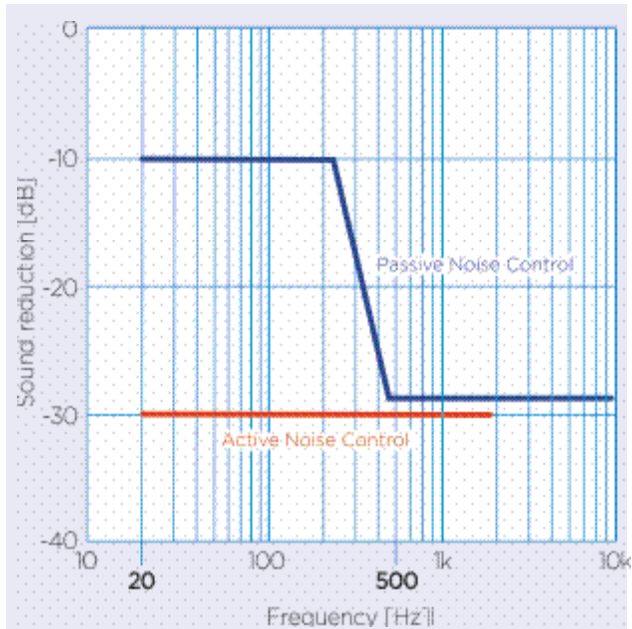

The idea of active noise control is 72 years old. The basic principle of ANC was established in 1936, when Paul Leug patented his active noise control system for air ducts. The principle of ANC is the superposition of two acoustic waves from a primary and a secondary source. When the two waves are 180 degrees out of phase and have the same amplitude, the result is the total cancellation of the two waves, which generates an acoustic or "silent" shadow zone.

#### 3.11.2. What is active noise control?

The active control of noise is that system that alters or cancels the sound by electro-acoustic means. In simple terms, the ANC is a system which causes a loudspeaker to emit a wave that is the inverse image of the sound wave to be cancelled, so the result after cancellation is silence.

### Concept of active noise control

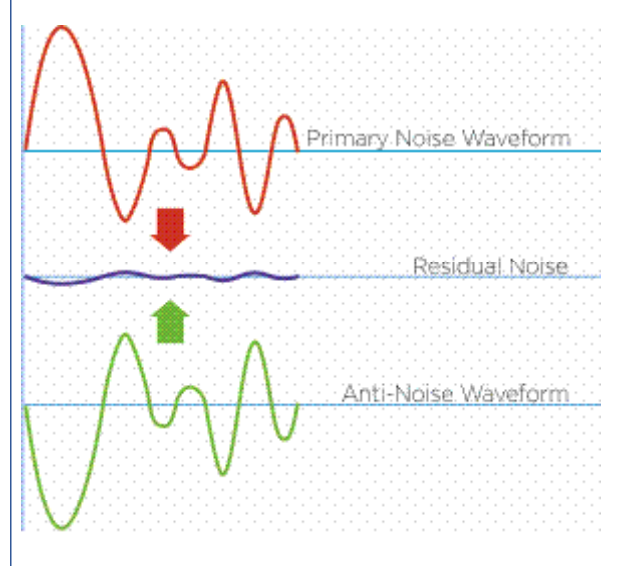

There is a big difference between active and passive systems for controlling noise. The passive methods use insulating materials, silencers, screens, enclosures, etc., and these passive systems are effective at medium and high frequencies, but they become large, very voluminous and uncomfortable at low frequencies. The size of the passive systems for noise control depends on the wavelength, being increasingly greater as the frequency decreases, so it highlights the need to implement active noise control systems.

There are four important elements in active noise control systems, which are as follows:

- The physical system to be controlled (sound source), such as the air flow in a ventilation duct.
- The sensors are microphones, accelerometers or other devices responsible for measuring noise and controlling how the control system works.
- The actuators are the devices that physically do the work of altering the response of the physical system; they are generally electromechanical devices such as loudspeakers or vibration generators.
- The controller is a signal processor that tells the actuators what to do. The controller is based on the signals received from the sensors, and on the knowledge of how the physical system responds to the effect of the actuators.

There are two basic types of active noise control:

- Active cancellation systems ANC (Active Noise Control).
- Acoustic structure systems ASAC (Active Structural-Acoustic Control).

In the ANC, the actuators are loudspeakers that generate a wave 180 ° out of phase with the original wave to cancel the noise. On the other hand, when noise is generated by the vibration of a flexible structure, ASACs are more appropriate since actuators are sources of vibration that can modify their structure, changing the way they radiate sound.

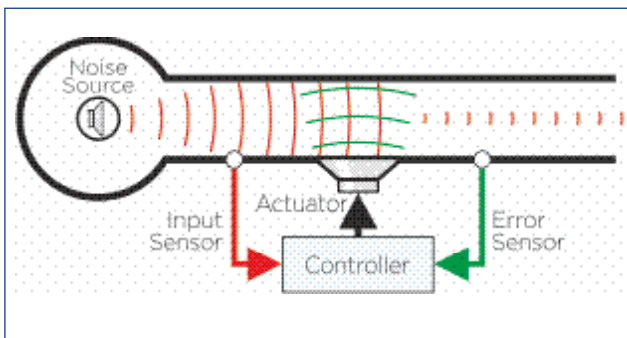

Although it goes against intuition, adding noise to a system effectively does reduce sound levels. Active noise control works when one or both physical effects are achieved – destructive interference and impedance matching.

It can be understood that the active control generates an anti-noise field that cancels the sound. The sound wave is the sequence of compressions (with high pressure) and expansions (with low pressure), and when a high pressure wave occurs in the same place and at the same time as a low pressure wave, the waves suffer from destructive interference and no change in pressure, which translates into silence.

ANC works best if the noise is regularly spaced, the classic example being a wave travelling in a conduit. Regular spacing refers to when the relationship between the wavelength is comparable to the dimensions of its closed environment, such as low frequencies and, as mentioned above, passive systems work best at high frequencies, which is why they are generally used together.

Noise control in complex spaces is still beyond today's technology. For example, controlling the noise that affects a house is extremely complex given the geometry and the number of high frequencies. On the other hand, it is easier to control a closed space such as a car cabin, where the size of the car is similar to or greater than the wavelength. And the extreme case is when you want to have control in a space that is closed and small compared to the wavelength. Even so, generally speaking, reducing noise in a space has the unwanted effect of amplifying the noise elsewhere. The ANC system reduces noise locally instead of globally.

### 3.11.3. Active noise control systems in ducts

ANC systems are based either on forward feed control, where a coherent noise signal is the reference signal, or on feedback control where the controller does not have the benefit of a reference signal. The systems are classified according to the type of noise they can cancel, whether they are broadband noise signals or narrowband signals.

#### Types of ANC system:

- Broadband ANC system with forward power, which uses an acoustic input sensor (microphone).
- Narrow band ANC system with forward power, which uses a non-acoustic input sensor.
- ANC system with feedback, which uses only one error sensor.

The figure below shows a typical noise control system. The noise that you want to cancel  $e$ , measured at the output of the system, is composed of the sum of the primary noise signal  $s$  travelling in the primary branch  $P$  and the controlled signal  $u$  travelling in branch  $G$ . The controlled signal  $u$  is calculated by a digital controller with advance power represented by  $T$ . The controller  $T$  needs a reference signal  $x$ , which loads some noise information. The reference signal is the result of the primary noise signal after traversing the  $R$  branch.

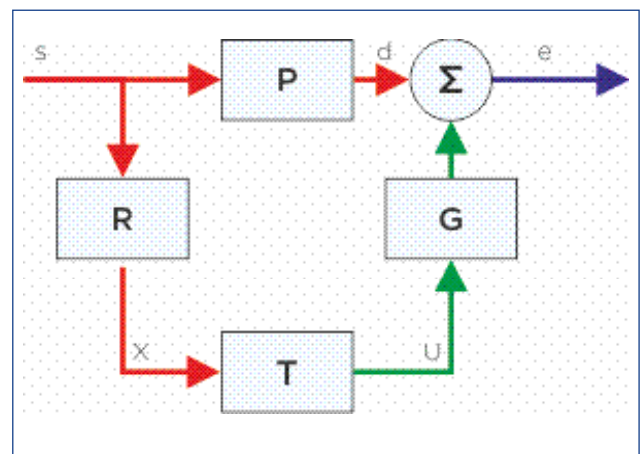

### ANC broadband system with forward power

Some examples of broadband noise are produced in ducts such as exhaust pipes and system ventilation. A relatively simple control system with forward feed-in in a conduit is shown in the figure below.  $X(n)$ , the reference signal, is detected by a microphone close to the noise source before the speaker passes. The noise canceller uses the reference input signal to generate a signal  $y(n)$  of the amplitude equal to  $x(n)$  but with a phase shift of  $180^\circ$ . This "anti-noise" signal is conducted to the loudspeaker to produce a sound that attenuates the primary acoustic noise in the duct.

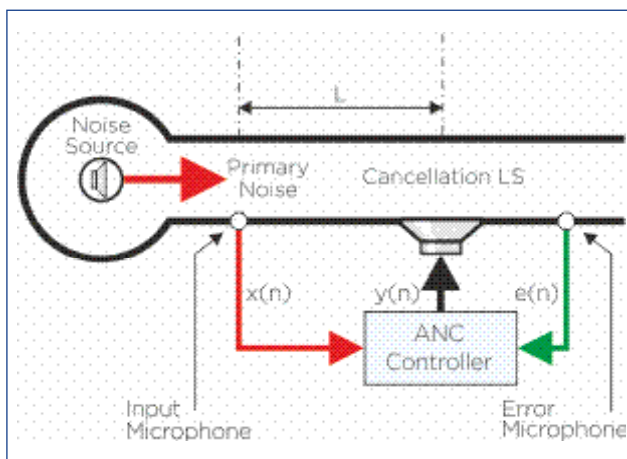

The basic principle of the broadband noise control technique by means of forward power is that the delay between the sensor (input microphone) and the active control source (loudspeaker) makes it possible to electrically reintroduce noise into a position in the acoustic field where cancellation will occur. The distance between the microphone at the entrance and the speaker must satisfy the principles of causality and high coherence, that is to say that the reference must be measured beforehand, so that the "anti-noise" signal can be generated at the moment the noise signal reaches the loudspeaker; it must also be ensured that the noise signal in the loudspeaker is very similar to the noise measured at the microphone input, that is, the acoustic channel must not change the noise in a perceptible manner.

The microphone at the output measures the error signal (residue), which is used to adapt the filter coefficients to minimise this error. Use of the error signal to adapt the filter coefficients does not represent feedback, since the error signal is not being compared with the input reference.

### Narrow band ANC system with forward power

In applications where the primary noise is periodic (or almost periodic) and is produced by rotating machinery, the input microphone can be replaced by a non-acoustic sensor such as a tachometer, an accelerometer, or an optical sensor. The block diagram of an active narrow band noise control system with forward power is shown in the following figure. The non-acoustic sensor signal is synchronous to the noise source and is used to simulate an input signal that contains the fundamental frequency and all the harmonics of the primary noise. This type of system controls harmonic noise by adaptively filtering the synthesised signal of the reference to produce a cancellation signal. In a lot of equipment, such as electric fan motors, turbo pumps and vehicles, the revolutions per minute (rpm) signal is available and can be used as the reference signal. An error microphone is still needed for measuring the residual noise signal. This error signal is used for adjusting the coefficients of the adaptive filter.

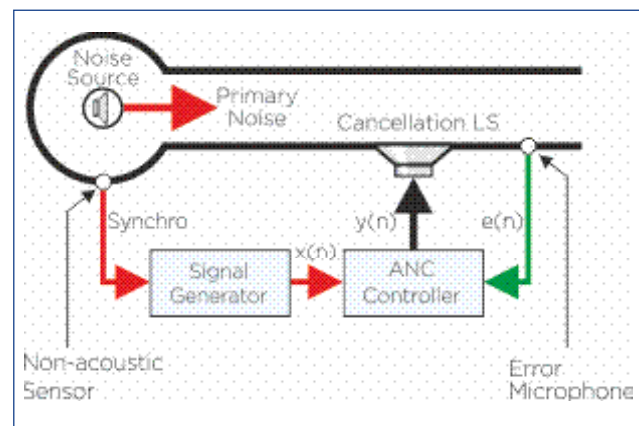

In general, the advantage of narrow band ANC systems is that the non-acoustic sensors are insensitive to cancellation sound, which produces very robust control systems. More specifically, this technique has the following advantages:

- The environmental and ageing problems of the input microphone are automatically eliminated. This is especially important from an engineering point of view because it is difficult to detect reference noise at high temperatures and in gas conduits, such as an engine's exhaust system.
- The fact that the primary noise signal is periodic makes it possible to disregard that the causality is fulfilled. The waveform of the noise has a constant content. Only phase and magnitude adjustments are required. This gives greater freedom with respect to speaker placement and allows the regulator to induce longer delays.
- The use of a reference signal generated by the regulator allows selective cancellation; that is, each harmonic can be controlled independently.
- It is only necessary to model the part of the acoustic transfer function of the physical system to be controlled regarding its harmonic tones. A low-order FIR filter can be used, making the periodic active noise control system more efficient.
- This avoids the problem of the microphone at the entrance creating feedback from the cancellation signal coming from the speaker.

Some other systems use forward power and feedback, like the system in the next figure. The feedback has added advantages in controlling noise and vibration.

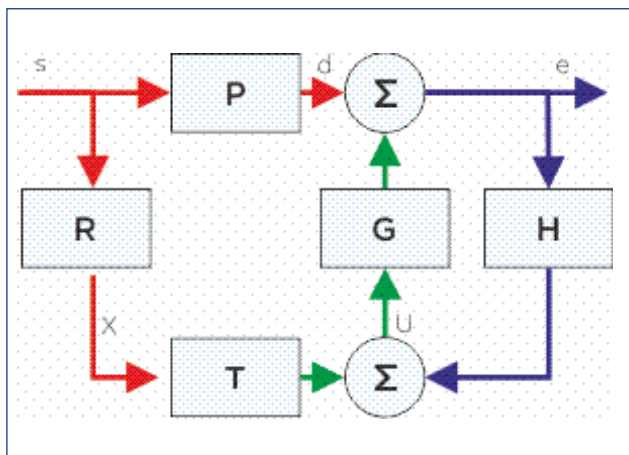

In many cases, the reference signal  $x$  can be difficult to obtain so an alternative is to use control systems without forward power, and only with feedback, as shown in the following figure.

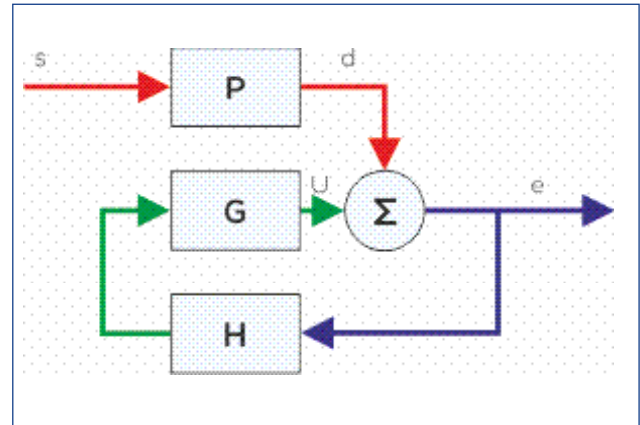

**ANC system with feedback**

The ANC control system with feedback was proposed by Olson and May in 1953. In this system, a microphone is used as an error sensor to detect unwanted noise. The signal of the error sensor is returned through an amplifier (electronic filter) with a magnitude and phase response designed to produce the cancellation in the sensor, by means of a loudspeaker placed near the microphone. This configuration provides only limited attenuation for periodic noise signals or with limited frequency band, in a restricted frequency range. It can also suffer from instability due to the predictable nature of narrow band signals.

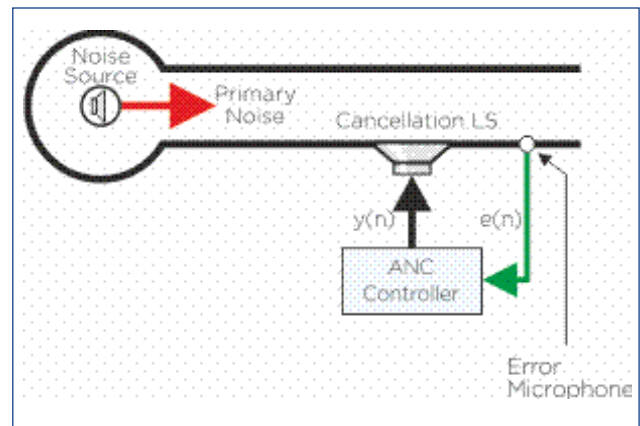

One application of the ANC system with feedback implemented by Olson is to control the acoustic field in hearing aids and ear protectors. In this application, the system reduces pressure fluctuations in the cavity near the user's ear. This application has been developed and is available commercially.

#### 3.11.4. Applications of active noise control systems

Active noise control is being used in various areas of commerce and industry in order to solve the problems caused by noise and vibration. Some known applications are as follows:

- The first sector to implement ANC was the military sector more than 20 years ago, using it in helicopter cabins to improve communication and reduce the noise level in the interior, and later to reduce the noise level produced by the rotor. In helicopters, ASAC (active structural-acoustic control) is also used in addition to ANC. ANC and ASAC are also applied in armoured tanks to reduce the noise level produced by the powerful diesel engines.
- Reduction of the noise level in the cabins of aircraft, cars and trucks. Vehicle manufacturers are experimenting with noise control to cancel the noise produced by the engine and the road.
- In large ventilation, heating and air conditioning systems, active noise control systems in conduits are already being used experimentally. The large capacities of ventilation systems produce high levels of noise and in many areas. Conventional methods of noise reduction have the consequence of reducing the air flow, which in turn reduces the speed of the fans, which in turn reduces the efficiency of the system. Active noise controls are used to attenuate low frequency noise, which results in an acoustically pleasant environment while saving energy in the ventilation systems at the same time.
- Active noise control is also being used to control the noise in aircraft turbines and has applications for the exhaust gases of combustion engines, both for vehicles and for generator engines.
- Noise control is widely used in voice transmissions, especially in situations where ambient noise reduces the quality of communication. For example, track controllers in airports, production plants, headphones, hearing protectors, etc. There are already smartphones with environmental noise cancellation systems to improve communication and intelligibility during telephone conversation.

## 4. Comfort, safety and measurements

### 4.1. Comfort and safety aspects of industrial noise

The acoustic environment influences the quality of the work areas threefold: health (risk of deafness), safety (communication problems and detection of danger signals) and acoustic comfort (more or less uncomfortable noisy environment). The legislation emphasises that hygiene is more important than safety and comfort. In such cases, we can refer to international standards. As a reference, the ISO standards that apply to issues of communication, safety and acoustic comfort are: ISO 9921, TR 3352, ISO 532, ISO 7196, ISO 8201 (audible emergency evacuation signals), ISO 7731 (hazard signs for workplaces – auditory hazard signs).

In most industrialised countries, there are regulations that indicate the limits of workers' exposure to noise in three zones or levels:

#### Exposure limit values

$L_{Aeq,d} > 87$  dB(A) and/or  $L_{peak} > 140$  dB(C)  
(When applying the limit values, the attenuation provided by the hearing protector will be taken into account)

#### Higher exposure values that give rise to action

$L_{Aeq,d} > 85$  dB(A) and/or  $L_{pico} > 137$  dB(C)

#### Lower exposure values that give rise to action

$L_{Aeq,d} > 80$  dB(A) and/or  $L_{pico} > 135$  dB(C)

Overcoming each of the reference levels entails a series of specific measures that the owner of the industry must assume:

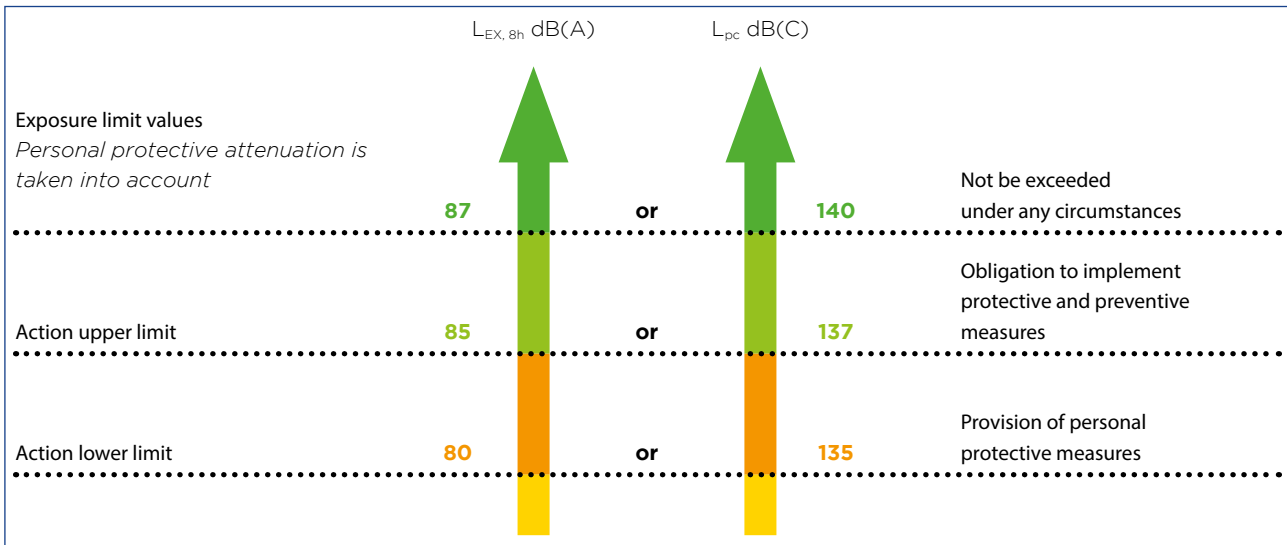

## 4.2. Acoustic magnitudes for measurements and verification methods

It is necessary to know which are the most commonly used acoustic measurements and verification methods in order to evaluate the existing noise, the noise control measures carried out and the knowledge of the insulation values of the proposed systems.

### 4.2.1. Measuring acoustic variables

#### Sound pressure level, $L_p$

$$L_p = 10 \log \left( \frac{P}{P_0} \right)^2$$

$P$  = existing sound pressure, in pascals

$P_0$  = reference sound pressure, that is  $2 \times 10^{-5}$  pascals

#### A-weighted sound pressure level, $L_{pA}$

$$L_{pA} = 10 \log \left( \frac{P_A}{P_0} \right)^2$$

$P_A$  = sound pressure, in pascals, A-weighting

#### Equivalent continuous A-weighted sound pressure level, $L_{Aeq,T}$

$$L_{Aeq,T} = 10 \log \frac{1}{T} \left[ \int_{t_1}^{t_2} \left( \frac{P_A(t)}{P_0} \right)^2 dt \right]$$

$T$  = time of exposure to noise, in hours/day

$t_1, t_2$  = measurement time

$P_A(t)$  = instantaneous acoustic pressure in pascals with the frequency weighting filter "A"

#### Level difference between enclosures, $D$

Difference, in dB, between the average sound pressure levels produced in two enclosures by the action of one or several noise sources emitting in one of them, which is called the emitting enclosure. In general, it is a function of the frequency. It is defined by the following expression:

$$D = L_1 - L_2 \quad [\text{dB}]$$

$L_1$  = average sound pressure level in the emitting enclosure, [dB]

$L_2$  = average sound pressure level in the receiving enclosure, [dB]

#### Standardised level difference between enclosures, $D_{nT}$

Difference between the average sound pressure levels produced in two enclosures by one or several noise sources emitting in one of them, standardised to the value 0.5 s of the reverberation time. In general, it is a function of frequency. It is defined by the following expression:

$$D_{nT} = L_1 - L_2 + 10 \log \frac{T}{T_0} \quad [\text{dB}]$$

$L_1$  = average sound pressure level in the emitting enclosure, [dB]

$L_2$  = average sound pressure level in the receiving enclosure, [dB]

$T$  = reverberation time of the receiving enclosure, [s]

$T_0$  = reference reverberation time; its value is  $T_0 = 0.5$  s

#### A-weighted standardised level difference between enclosures, $D_{nT,A}$

Overall rating, in dB(A), of the standardised difference in levels, between indoor enclosures,  $D_{nT}$ , for pink noise. It is defined by the following expression:

$$D_{nT,A} = -10 \log \sum_{i=1}^n 10^{(L_{Ar,i} - D_{nT,i})/10} \quad [\text{dBA}]$$

$D_{nT,i}$  = standardised level difference in the frequency band  $i$ , [dB]

$L_{Ar,i}$  = value of the standardised pink noise spectrum, A-weighted, in the frequency band  $i$ , [dB(A)]

$i$  = all third-octave bands from 100 Hz to 5 kHz

**Apparent sound reduction index, R'**

Acoustic insulation, in dB, of a constructive element measured on site, including indirect transmissions. It is a function of frequency. It is defined by the following expression:

$$R' = L_1 - L_2 + 10 \log \frac{S}{A} \quad [dB]$$

- L<sub>1</sub> = average sound pressure level in the emitting enclosure, [dB]
- L<sub>2</sub> = average sound pressure level in the receiving enclosure, [dB]
- S = area of the constructive element, [m<sup>2</sup>]
- A = equivalent absorption area of the receiving enclosure, [m<sup>2</sup>]

**Sound reduction index, R**

Acoustic insulation, in dB, of a constructive element measured in the laboratory. It is a function of frequency. It is defined by the following expression:

$$R = L_1 - L_2 + 10 \log \frac{S}{A} \quad [dB]$$

- L<sub>1</sub> = average sound pressure level in the emitting enclosure, [dB]
- L<sub>2</sub> = average sound pressure level in the receiving enclosure, [dB]
- S = area of the constructive element, [m<sup>2</sup>]
- A = equivalent absorption area of the receiving enclosure, [m<sup>2</sup>]

**Indirect sound reduction index, R<sub>ij</sub>**

Difference between the sound levels of the emitting and receiving enclosures due to the acoustic transmission caused indirectly or by flanks.

**Overall A-weighted apparent sound reduction index, of constructive element, R'<sub>A</sub>**

Overall rating, in dB(A), of the apparent sound reduction index R', for a pink incident noise, standardised, A-weighted. It is defined by the following expression:

$$R'_A = -10 \log \sum_{i=1}^n 10^{(L_{A_i} - R'_i)/10}$$

- R'<sub>i</sub> = apparent sound reduction index in the frequency band i, [dB]
- L<sub>A<sub>ri</sub></sub> = value of the standardised pink noise spectrum, weighted A, in the frequency band i, [dB(A)]
- i = all third-octave bands from 100 Hz to 5 kHz

**Weighted apparent sound reduction index, R'<sub>w</sub>**

Decibel value of the reference curve, to 500 Hz, adjusted to the experimental values of the apparent sound reduction index, R'.

**Overall A-weighted sound reduction index of constructive element, R<sub>A</sub>**

Overall rating, in dBA, of the sound reduction index, R', for a standardised pink incident noise, A-weighted. The sound reduction index will be determined by a laboratory test. From the values of the sound reduction index R, obtained by a laboratory test, this index is defined by the following expression:

$$R_A = -10 \log \sum_{i=1}^n 10^{(L_{A_i} - R_i)/10}$$

- R<sub>i</sub> = value of the sound reduction index in the frequency band i, [dB]
- L<sub>A<sub>ri</sub></sub> = value of the pink noise spectrum, A-weighted, in the frequency band i, [dB(A)]
- i = all third-octave bands from 100 Hz to 5 kHz

It can be approximately considered that R<sub>A</sub> = R<sub>w</sub> + C

**Overall A-weighted sound reduction index, for outdoor automotive noise, R<sub>Atr</sub>**

Overall rating, in dB(A), of the sound reduction index, R', for outdoor automotive noise. It is defined by the following expression:

$$R_{Atr} = -10 \log \sum_{i=1}^n 10^{(L_{Atr_i} - R_i)/10}$$

- R<sub>i</sub> = value of the sound reduction index in the frequency band i, [dB]
- L<sub>A<sub>ri</sub></sub> = value of the pink noise spectrum, A-weighted, in the frequency band i, [dB(A)]
- i = all third-octave bands from 100 Hz to 5 kHz

It can be approximately considered that R<sub>Atr</sub> = R<sub>w</sub> + C<sub>tr</sub>

**Weighted sound reduction index,  $R_w$** 

Decibel value of the reference curve, to 500 Hz, adjusted to the experimental values of the sound reduction index, R according to the method specified in the EN ISO 717-1.

**Standardized impact sound pressure level,  $L'_{nT}$** 

Average sound pressure level, in dB, in the standardised receiving enclosure at a reverberation time of 0.5 s, when the constructive separation element, with respect to the emitting enclosure, is excited by the standardised impact machine. It is a function of the frequency. It is defined by the following expression:

$$L'_{nT} = L - 10 \log \frac{T}{T_0} \quad [\text{dB}]$$

L = average sound pressure level in the receiving enclosure, [dB]

T = reverberation time of the receiving enclosure, [s]

$T_0$  = reference reverberation time; its value is  $T_0 = 0.5$  s

**Normalised impact sound pressure level,  $L_n$** 

Average sound pressure level in the receiving room, referred to an absorption of 10 m<sup>2</sup>, with the horizontal construction element mounted as a separation element with respect to the upper enclosure. Such an element is excited by the standardised impact machine, under laboratory test conditions (absence of indirect transmissions). It is a function of frequency. It is defined by the following expression:

$$L_n = L + 10 \log \frac{A}{10} \quad [\text{dB}]$$

L = average sound pressure level of impacts in the receiving enclosure, [dB]

A = equivalent absorption area of the receiving enclosure, [m<sup>2</sup>]

**Overall normalized impact sound pressure level on site,  $L'_{n,w}$** 

It is the value at 500 Hz of the reference curve adjusted to the experimental values of standardised impact noise pressure level  $L'_n$ . If the experimental levels are given for octave bands, the value at 500 Hz is reduced by 5 dB.

**Normalised impact sound pressure level on site,  $L'_n$** 

This is the average level of sound pressure in the standardised receiving enclosure at an acoustic absorption of 10 m<sup>2</sup>, when the constructive separation element, with respect to the upper enclosure, is excited by the standardised impact machine. It is a function of frequency. It is defined by the following expression:

$$L'_n = L + 10 \log \frac{A}{10} \quad [\text{dB}]$$

L = average sound pressure level in the receiving enclosure, [dB]

A = equivalent absorption area of the receiving enclosure, [m<sup>2</sup>]

#### 4.2.2. Verification methods

The acoustic sources, noise control devices, sound propagation, noise levels in work areas and acoustic insulation are defined by means of acoustic magnitudes. These acoustic variables are often determined or agreed upon in plans, programs and contracts. The value of these acoustic variables and the success of noise control measures must be verifiable on site. Uncertainty should always be taken into account when comparing these values with those that have been verified.

#### Acoustic measurements

Noise level measurements require experience and theoretical knowledge of the parameters to be measured, as well as the functioning of the measurement equipment. The principles described below can help you understand the specific characteristics of these important aspects of noise control.

ISO 1996 "Acoustic: Description, measurement and evaluation of environmental noise" explains the main aspects in reference to measurements in the environmental field. For the evaluation of noise in the workplace, ISO 9612 "Acoustics. Determination of exposure to noise at work" can be applied.

The noise levels measured are divided conceptually into instantaneous and equivalent. The former follows the changes in the acoustic level with more or less speed (fast, slow, impulse), and the latter will evaluate the total acoustic energy received in a given time ( $L_{eq}$ , etc.). All these magnitudes can be determined with different frequency weights (A, C, linear). The peak level ( $L_{pk}$ ) is a parameter that characterises the impulse component of noise.

#### Measurement equipment

The technical characteristics that the different measuring equipment must show are reflected in the standards CEI 61672 and CEI 60804. The most frequently used equipment are sound level meters (instantaneous measurements) and sound level meters for integration and averaging (equivalent levels). They are classified according to their accuracy (0 to 2), with type 1 being the most accurate for field measurements.

The noise level measuring equipment must be calibrated and checked periodically, before and after each measurement, with a properly calibrated "piston".

#### Measurement methods

The standards generally give instructions regarding the methods of measurement, and will take into account, among others, the following:

- Absence of reflecting surfaces in the environment (1.2 m high and 1.5 m to the nearest surface).
- End noise less than 10 dB at the measurement level.
- Use of screens for protection against wind, when necessary.

#### Sound sources

The noise emission declaration of a machine can be verified using the methods given in ISO 4871. The noise emission data should be verified using the machine-specific noise test code and the basic standards for noise emission measurement (ISO 3740 series, ISO 9614 series and ISO 11200 series). When verifying the declared values, it is essential that the operating and assembly conditions are the same as those specified in the noise emission declaration or the machine documents. The noise control measures are evaluated by determining the difference in noise emission.

#### Noise control systems

The effectiveness of noise control devices can be measured and verified using insertion loss, loss of transmission or reduction of sound pressure levels. The buyer and the seller must agree on the descriptor to use.

### Areas of work

The acoustic quality of work areas and offices can be evaluated using the following sound propagation parameters: spatial decay ( $DL_2$ ), excess ( $DL_r$ ) of the sound pressure level and reverberation time. These three quantities can be measured or calculated (see ISO 11690-3). The values must be calculated and agreed upon between the parties during the planning stage. It should always be necessary to verify the initial calculated values with the acoustic measurements made on site.

Verification method: An omnidirectional sound source of known noise power must be used. The source should be located near the ground with all measurement points set at the same height.

The propagation of the sound must be determined for the level of general sound pressure with a given frequency distribution or in octave bands. Normally, it is measured in an area that guarantees a clear path between the source and the measuring point. When comparing the given and verified values, it is essential that the distribution and distances are the same.

The effectiveness of noise control and noise emission can be determined and verified by taking into account the level of sound pressure in specific positions, usually the work areas. The situations before and after the noise control measures can only be compared if the operating conditions and the measurement method used are identical.

## 5. Examples of noise control

### 5.1. Absorbent treatments

Most industrial premises are exposed to noise levels that disturb the normal activity and wellbeing of people and workers. The noise generated in the premises by internal sources is very varied and proceeds from a few localised sources to a significant number of sources that are not localised and are randomly distributed throughout the premises.

Evidently, different problems require different solutions, and the problem also frequently demands more than one solution simultaneously. The absorbent treatment is the most appropriate when the number of noisy sources is important, although its sound level is not individually elevated. If the distribution of these sources in a room is very extensive and mobile, a substantial noise is generated that can only be reduced by action in the reverberated field, within the limitations that it entails, increasing the value of the absorbent area in the enclosure. The average value of sound reduction in a room, assuming a diffuse reverberated field, modifying its absorbent area is:

$$\Delta L = 10 \log \frac{A_1}{A_0} = 10 \log \frac{T_0}{T_1} \quad [\text{dB}]$$

L = reduction of the average sound level in the room

$A_1$  = increased absorbing area of the room, [m<sup>2</sup>]

$A_0$  = initial absorbing area of the room, [m<sup>2</sup>]

$T_0$  = starting reverberation time of the room, [s]

$T_1$  = reverberation time of the room, increased absorption, [s]



To achieve absorption improvements, we can use:

- Acoustic ceilings consisting of rigid panels made of mineral wool, with decorative functional elements in its visible part, which are installed suspended from the ceiling by visible or hidden profiles (Saint-Gobain Ecophone and Eurocoustic products).
- Acoustic baffles formed by absorbent plates mounted in rigid frames forming geometric figures that are suspended from the ceiling. The figures are varied, but they are mainly narrow parallelepiped and cylinders.
- Acoustic murals consisting of decorative panels of flat or corrugated shapes, capable of being installed parallel to vertical enclosures, and composed of acoustic absorbent elements. The important functional characteristic of all these systems is their spectrum of absorption coefficient with frequency.



**Example**

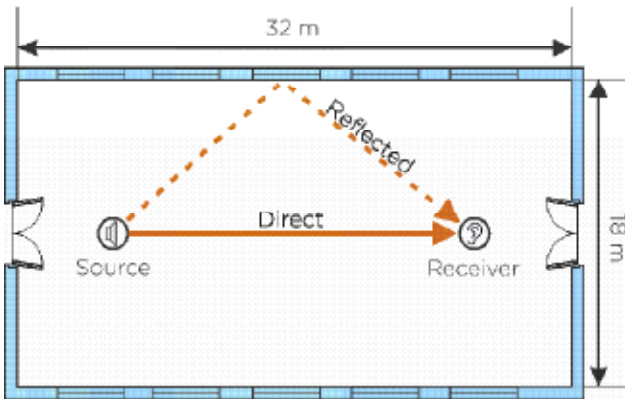

This is about knowing the general decrease of the sound level in an industrial building with a length of 32 m, a width of 18 m and a height of 5 m, whose typological and occupation characteristics are as follows:

**Surfaces of the industrial building enclosures**

- Ceiling-cover sandwich panel with smooth steel sheet on the inside: 576 m<sup>2</sup>
- Vertical closing walls of visible reinforced concrete: 468 m<sup>2</sup>
- Steel sheet doors: 2 units of 4 x 4 m = 32 m<sup>2</sup>
- Floor of concrete pavement, painted: 576 m<sup>2</sup>
- Occupation: 20 people
- Enclosure volume: 2,880 m<sup>3</sup>

**Acoustic absorption coefficient of interior materials**

- Average value of the acoustic absorption coefficient for frequencies from 100 Hz to 5,000 Hz
- Ceiling cover: 0.01
- Concrete parameter: 0.03
- Doors: 0.01
- Concrete floor: 0.015
- One person: 0.40

**a) Enclosure reverberation time calculation**

First, the existing absorbent area is according to the expression:

$$A = \sum \alpha_i S_i$$

Enclosure	S [m <sup>2</sup> ]		A [m <sup>2</sup> ]
Ceiling cover	576.0	0.01	5.8
Concrete walls	468.0	0.03	14.0
Doors	32.0	0.01	0.3
Floor	576.0	0.015	8.6
Workers	20.0	0.4	8.0
<b>Absorbent area [m<sup>2</sup>]</b>			<b>36.76</b>

In accordance with Sabine's theory, the reverberation time of the enclosure is given by the expression:

$$T_0 = \frac{0.161V}{A_0}$$

V = Enclosure volume	2,880.00 m <sup>3</sup>
A <sub>0</sub> = Initial absorbent area	36.76 m <sup>2</sup>

**T<sub>0</sub> = 12.61 s**

**b) Calculation of the reverberation time with absorbent treatment of the enclosure**

With a ceiling and a strip of 2 m high with absorbent material formed by TECH SLAB 3.0 G1 that is 50 mm thick, covered by a galvanised perforated plate that has a thickness of 0.8 mm, a perforation diameter of 5 mm, an offset arrangement and 60 % perforation. The perimeter strip will be 2 m except for the upper part of the doors, which will be 1 m.

**Surfaces of the industrial building enclosures**

• Absorbent ceiling cover:	576 m <sup>2</sup>
• Absorbent perimeter strip:	200 m <sup>2</sup>
• Vertical closing walls of visible reinforced concrete:	268 m <sup>2</sup>
• Steel sheet doors: 2 units of 4 x 4 m =	32 m <sup>2</sup>
• Floor of concrete pavement, painted:	576 m <sup>2</sup>
• Occupation	20 people
• Enclosure volume:	2,880 m <sup>3</sup>

**Acoustic absorption coefficient of interior materials**

• Average value of the acoustic absorption coefficient for frequencies from 100 Hz to 5,000 Hz	
• Absorbent material TECH SLAB 3.0 G1:	0.90
• Concrete parameter:	0,03
• Doors:	0.01
• Concrete floor:	0.015
• One person:	0.40

Firstly, for the calculation of the reverberation time and the absorbent area, the Millington-Sette expression is used, since there are several surfaces with very different absorption coefficients, and the following expression is used:

$$A_1 = - \sum S_i \ln(1 - \alpha_i)$$

Enclosure	S [m <sup>2</sup> ]		A [m <sup>2</sup> ]
Absorbent ceiling	576.0	0.90	1,326.3
Absorbent perimeter strip	200.0	0.90	460.5
Concrete walls	268.0	0.03	8.2
Doors	32.0	0.01	0.3
Floor	576.0	0.015	8.7
Workers	20.0	0.4	10.2
<b>Absorbent area [m<sup>2</sup>]</b>			<b>1,814.21</b>

$$T_{60} = \frac{0.161V}{-\sum_i S_i \ln(1 - \alpha_i)}$$

V = Enclosure volume	2,880.00 m <sup>3</sup>
A <sub>0</sub> = Final absorbent area	1,814.21 m <sup>2</sup>

**T<sub>0</sub> = 0.26 s**

**c) Reduction of the sound pressure level, in the reverberated field**

The reduction of the sound pressure level can be calculated according to the absorbent area of the enclosure, with and without acoustic absorbent treatment, and also depending on the reverberation times obtained.

With the absorbing area data

$$\Delta L = 10 \log \frac{A_1}{A_0}$$

$$\Delta L = 16.9 \text{ dB}$$

With the reverberation time data

$$\Delta L = 10 \log \frac{T_0}{T_1}$$

$$\Delta L = 16.8 \text{ [dB]}$$

It should be specified that the calculated average sound reduction occurs in the areas of the reverberant field and not in the near field of the source. These same calculations can be made for each octave band, from the values of the absorption coefficient by octave bands of each of the materials, thus achieving the sound reduction that is produced by frequency bands.

## 5.2. Noise control in ducts

A typical way of transmitting airborne noise is in the systems of air conditioning and ventilation ducts, as well as the systems of aspiration and expulsion of air in cabins. The most frequent sound damping solutions go through acoustic absorption techniques. A conduit of sufficient length with respect to its section can attenuate the sound inside it according to the following empirical expression:

$$\Delta L = 1.05 \cdot \alpha^{1.4} \cdot \frac{P}{S} \quad \text{dB/m}$$

where:

- L = sound damping per length unit of the duct
- α = absorption coefficient of the interior material of the duct in -Sabine
- P = inside perimeter of the conduit, [m]
- S = inside section of the conduit, [m<sup>2</sup>]

### Example

Calculate the resulting sound level after 5 m of duct in different configurations: metal, self-supporting glass wool Climaver Plus R, Climaver Neto and Climaver Fit section 400 x 200 mm if the sound source is a helical fan (5 kW) that moves an air flow of 25,000 m<sup>3</sup>/h, overcoming a pressure loss of 35 mm of water column.

The sound power generated by a fan can be estimated using the Madison-Graham formula or the Allen formula:

$$L_w = 25 + 10 \log Q + 20 \log P$$

$$L_w = 77 + 10 \log W + 10 \log P$$

Q = air flow	25,000 m <sup>3</sup> /h
P = static pressure	35 mm cda
W = fan power	5 kW

### So the sound power level of the fan would be:

L <sub>w</sub> according to Madison-Graham formula	99.9 dB
L <sub>w</sub> according to Allen formula	99.4 dB

If the correction coefficients for a helical fan (not indicated) are introduced, the following noise spectrum will be obtained:

F [Hz]	63 Hz	125 Hz	250 Hz	500 Hz	1kHz	2kHz	4kHz	8kHz	dB
L <sub>w</sub> [dB] Fan	95.5	91.8	92.7	90.2	88.1	87.8	86	79.1	99.9

The sound pressure level at 1 m of the fan in its pressure port is determined according to the expression:

$$L_p = L_w + 10 \log \left( \frac{Q}{4\pi r^2} \right)$$

Q = directivity factor	1
r = distance	1 m

F [Hz]	63 Hz	125 Hz	250 Hz	500 Hz	1kHz	2kHz	4kHz	8kHz	dB
L <sub>w</sub> [dB] Fan	84.5	80.8	81.7	79.2	77.1	76.8	75.0	68.1	100.2

Acoustic absorption coefficients of the materials that make up the duct with a plenum greater than 25 cm:

F [Hz]	63 Hz	125 Hz	250 Hz	500 Hz	1kHz	2kHz	4kHz	8kHz
<b>Metal duct</b>		0.07	0.07	0.19	0.19	0.10	0.10	
<b>Climaver Plus R</b>		0.20	0.20	0.20	0.60	0.50	0.40	
<b>Climaver Neto</b>		0.35	0.65	0.75	0.85	0.90	0.90	
<b>Climaver Apta</b>		0.40	0.60	0.80	0.90	0.90	0.90	

It is necessary to calculate the P/S ratio of the conduit under consideration

$$\frac{P}{S} = \frac{0.2 * 2 + 0.4 * 2}{0.2 * 0.4} = 15$$

Applying the following formula, we can calculate the attenuation for 10 m of length

$$AL = 1.05 \cdot \alpha^{1.4} \cdot \frac{P}{S} \quad [dB/m]$$

F [Hz]	63 Hz	125 Hz	250 Hz	500 Hz	1kHz	2kHz	4kHz	8kHz
<b>Metal duct</b>		1.9	1.9	7.7	7.7	3.1	3.1	
<b>Climaver Plus R</b>		8.3	8.3	8.3	38.5	29.8	21.8	
<b>Climaver Neto</b>		18.1	43.1	52.6	62.7	68.0	68.0	
<b>Climaver Apta</b>		21.8	38.5	57.6	68.0	68.0	68.0	

With the spectrum of the sound pressure level of the fan at 1 m and the duct attenuation, we can calculate the sound pressure level at a distance of 6 m from the source (5 + 1 m)

F [Hz]	63 Hz	125 Hz	250 Hz	500 Hz	1kHz	2kHz	4kHz	8kHz	dB
<b>L<sub>p</sub> (dB) fan at 6 m Metal duct</b>		78.9	79.8	71.5	69.4	73.7	71.9		83.7
<b>L<sub>p</sub> (dB) fan at 6 m Climaver Plus R</b>		72.5	73.4	70.9	38.6	47.0	53.2		77.2
<b>L<sub>p</sub> (dB) fan at 6 m Climaver Neto</b>		62.7	38.6	26.6	14.4	8.9	7.1		62.7
<b>L<sub>p</sub> (dB) fan at 6 m Climaver Apta</b>		59.0	43.2	21.6	9.2	8.9	7.1		59.1

To obtain the values in dB(A), we must apply the weighting curve A to the previous values

F [Hz]	63 Hz	125 Hz	250 Hz	500 Hz	1kHz	2kHz	4kHz	8kHz
<b>A-weighting</b>	-26.0	-16.0	-9.0	-3.2	0.0	1.2	1.0	- 1.1

F [Hz]	63 Hz	125 Hz	250 Hz	500 Hz	1kHz	2kHz	4kHz	8kHz	dBA
<b>L<sub>p</sub> [dBA] fan at 6 m Metal duct</b>		62.9	70.8	68.3	69.4	74.9	72.9		79.0
<b>L<sub>p</sub> [dBA] fan at 6 m Climaver Plus R</b>		56.5	64.4	67.7	38.6	48.2	54.2		69.8
<b>L<sub>p</sub> [dBA] fan at 6 m Climaver Neto</b>		46.7	29.6	23.4	14.4	10.1	8.1		46.8
<b>L<sub>p</sub> [dBA] fan at 6 m Climaver Apta</b>		43.0	34.2	18.4	9.2	10.1	8.1		43.5

It should be specified that the above resulting values are theoretical and do not represent the effective attenuation since the real values obtained in a network of ducts, in addition to the fan noise, depend on another series of factors such as the air speed, the type of derivations, grids, diffusers, section changes, etc.

### 5.3. Silencers

Another solution for reducing noise in ventilation and air conditioning ducts is the installation of acoustic absorption silencers.

**Example**

Calculate the resulting sound level after inserting a silencer that is 1.5 m wide, B m high, 1.2 m long, backdrops of 200 mm and air flow of 100 mm if the sound source is a helicoidal fan (5 kW) that moves an air flow of 24,300 m<sup>3</sup>/h, overcoming a pressure loss of 35 mm of water column. Starting data: power level of the drive side fan (A = 1.5 m; L = 1.2 m; e = 200 mm; d = 100 mm).

The power levels by octave bands of the fan are as follow:

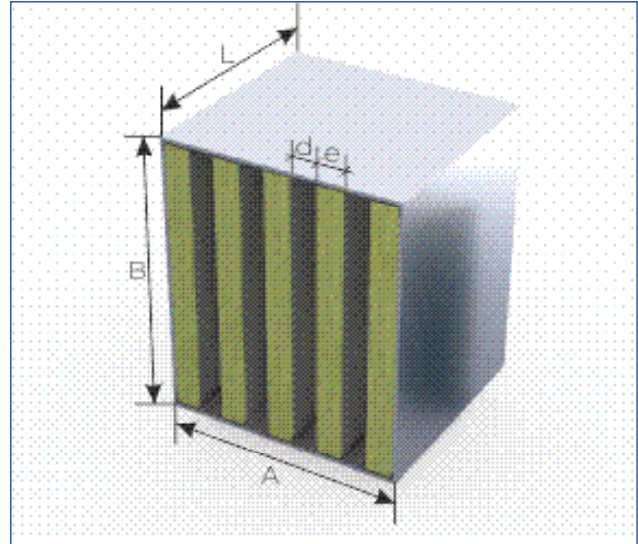

F [Hz]	63 Hz	125 Hz	250 Hz	500 Hz	1kHz	2kHz	4kHz	8kHz	dB
<b>L<sub>w</sub> [dB] Fan (data from catalogue)</b>	93.7	94.5	95.4	92.3	88.1	87.8	86	79.1	100.8

The sound pressure level at 1 m of the fan in its pressure port is determined according to:

$$L_p = L_w + 10 \log \left( \frac{q}{4\pi r^2} \right)$$

Q = directivity factor	1
r = distance	1 m

F [Hz]	63 Hz	125 Hz	250 Hz	500 Hz	1kHz	2kHz	4kHz	8kHz	dB
<b>L<sub>p</sub> [dB] at 1m Fan</b>	82.7	83.5	84.4	81.3	77.1	76.8	75.0	68.1	100.2

Calculation of the silencer dimensions for a speed of 10 m/s

$$v = \frac{Q}{S}$$

Q = air flow	24300 m <sup>3</sup> /h
S = air passage section	0.5 H m <sup>2</sup>
Silencer width	1.5 m
Number of channels W/(baffle + air passage)	5
Air passage width	0.1 m
H = height	1.35 m

F [Hz]	63 Hz	125 Hz	250 Hz	500 Hz	1kHz	2kHz	4kHz	8kHz
<b>Silencer attenuation 1,200 mm length (100 air passage and 200 mm of baffle, data from catalogue)</b>	6.0	12.0	25.0	38.0	47.0	45.0	35.0	28.0

With the spectrum of the sound pressure level of the fan at 1 m and the duct attenuation, we can calculate the sound pressure level at the silencer output

F [Hz]	63 Hz	125 Hz	250 Hz	500 Hz	1kHz	2kHz	4kHz	8kHz	dB
<b>L<sub>p</sub> [dB] Silencer outlet</b>	76.7	71.5	59.4	43.3	30.1	31.8	40.0	40.1	77.9

To obtain the values in dB(A), we must apply A-weighting to the previous values

F (Hz)	63 Hz	125 Hz	250 Hz	500 Hz	1kHz	2kHz	4kHz	8kHz
<b>A-weighting</b>	-26.0	-16.0	-9.0	-3.2	0.0	1.2	1.0	-1.1

F [Hz]	63 Hz	125 Hz	250 Hz	500 Hz	1kHz	2kHz	4kHz	8kHz	dBA
<b>L<sub>p</sub> [dBA] Silencer outlet</b>	50.7	55.5	50.4	40.1	30.1	33.0	41.0	39.0	57.9

It should be specified that the values above are theoretical and do not represent the effective attenuation since the actual values obtained depend on the acoustic termination of the silencer, the level of background noise and reflections at the end of the silencer, etc., but they give us calculation values prior to installation.

### 5.4. Acoustic barriers

**Example**

Calculate the resulting sound level in the receiver located 4.5 m from the sound source, if an acoustic screen is placed at 2 m from the source and at 2.5 m from the receiver; see the following sketch, and knowing the sound level in third-octaves in the receiver without an acoustic barrier.

Screen height	4.5 m
Receiver height	2.5 m
Source height	1.2 m

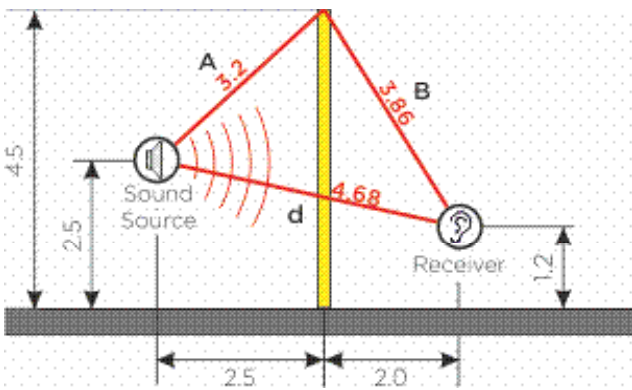

First of all, it is necessary to calculate the Fresnel number for each frequency as a function of A, B and d, to later calculate the acoustic attenuation (see attached graph), considering a stationary source.

$$N = \frac{1}{\lambda} \left( \frac{A + B - d}{2} \right)$$

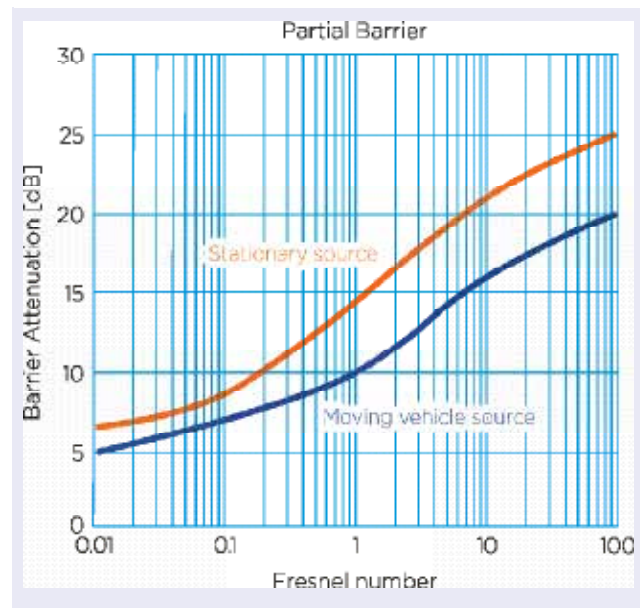

Acoustic barrier attenuation						
Attenuation [dB]	Fresnel number	A [m]	B [m]	d [m]	[m]	Frequency [Hz]
15.5	1.40	3.2	3.86	4.68	3.400	100
15.8	1.75	3.2	3.86	4.68	2.720	125
16.6	2.24	3.2	3.86	4.68	2.125	160
17.3	2.80	3.2	3.86	4.68	1.700	200
18.3	3.50	3.2	3.86	4.68	1.360	250
18.8	4.41	3.2	3.86	4.68	1.079	315
19.3	5.60	3.2	3.86	4.68	0.850	400
20.3	7.00	3.2	3.86	4.68	0.680	500
20.8	8.82	3.2	3.86	4.68	0.540	630
20.9	11.20	3.2	3.86	4.68	0.425	800
21.4	14.00	3.2	3.86	4.68	0.340	1000
21.8	17.50	3.2	3.86	4.68	0.272	1250
22.3	22.40	3.2	3.86	4.68	0.213	1600
22.8	28.00	3.2	3.86	4.68	0.170	2000
23.3	35.00	3.2	3.86	4.68	0.136	2500
23.6	44.10	3.2	3.86	4.68	0.108	3150
23.8	56.00	3.2	3.86	4.68	0.085	4000
24.4	70.00	3.2	3.86	4.68	0.068	5000
24.8	88.20	3.2	3.86	4.68	0.054	6300
25.1	112.00	3.2	3.86	4.68	0.043	8000
25.4	140.00	3.2	3.86	4.68	0.034	10000

Applying the acoustic attenuation to the existing sound pressure levels, we achieve the sound pressure levels in the receiver with the installed acoustic screens, including the correction by A-weighting.

Frequency [Hz]	L <sub>eq</sub> initial receiver [dB]	L <sub>eq</sub> final receiver [dB]	L <sub>eq</sub> initial receiver [dB(A)]	L <sub>eq</sub> final receiver [dB]	A-weighting	TL [dB(A)]
100	70.1	54.6	51.0	35.5	-19.1	15.50
125	64.8	49.0	48.7	32.9	-16.1	15.80
160	72.1	55.5	58.7	42.1	-13.4	16.60
200	69.2	51.9	58.3	41.0	-10.9	17.30
250	68.2	49.9	59.6	41.3	-8.6	18.30
315	69.9	51.1	63.3	44.5	-6.6	18.80
400	68.8	49.5	64.0	44.7	-4.8	19.30
500	70.7	50.4	67.5	47.2	-3.2	20.30
630	66.1	45.3	64.2	43.4	-1.9	20.80
800	66.6	45.7	65.8	44.9	-0.8	20.90
1,000	63.2	41.8	63.2	41.8	0.0	21.40
1,250	66.3	44.5	66.9	45.1	0.6	21.80
1,600	71.8	49.5	72.8	50.5	1.0	22.30
2,000	61.9	39.1	63.1	40.3	1.2	22.80
2,500	56.2	32.9	57.5	34.2	1.3	23.30
3,150	59.7	36.1	60.9	37.3	1.2	23.60
4,000	52.5	28.7	53.5	29.7	1.0	23.80
5,000	52.5	28.1	53.0	28.6	0.5	24.40
6,300	51.1	26.3	51.0	26.2	-0.1	24.80
8,000	48.4	23.3	47.3	22.2	-1.1	25.10
10,000	46.0	20.6	43.5	18.1	-2.5	25.40
<b>AP</b>	<b>80.3</b>	<b>61.8</b>	<b>77.0</b>	<b>55.9</b>		<b>-21.04</b>

It should be specified that the calculated average sound reduction occurs in the shadow area of the acoustic screen with values of Fresnel number greater than 1. As the receiver moves away from the screen, the screen effect decreases considerably, and from a distance, practically no attenuation occurs for values of the Fresnel number < 0.02.

**The sound pressure levels have dropped from the initial 77.0 dB(A) to the final 55.9 dB(A).**

## 5.5. Acoustic enclosures

### Example

Calculate the sound pressure level in dB(A) at 5 m distance from the sound source after installing an acoustic enclosure at the sound source of the sound power level spectrum. The acoustic enclosure consists of removable acoustic panels formed from the outside to the inside by a 1.0 mm thick layer of galvanised steel

sheet, 80 mm thick layer of internal core of mineral wool panel of TECH SLAB 3.0 G1, and 0.8 mm thick layer of perforated galvanized steel sheet.

#### Enclosure dimensions

6 m length x 3 m width x 3 m height

#### Sound source dimensions

4 m length x 1 m width x 2 m height

#### Sound power levels by octave bands of the sound source

F [Hz]	63 Hz	125 Hz	250 Hz	500 Hz	1kHz	2kHz	4kHz	8kHz	dB
<b>L<sub>w</sub> [dB] Source</b>	94.1	96.2	98.8	97.5	95.4	91.3	90.0	89.7	104.3

#### Sound reduction index of the acoustic enclosure that is installed around the source

F [Hz]	63 Hz	125 Hz	250 Hz	500 Hz	1kHz	2kHz	4kHz	8kHz
<b>R [dB] Acoustic enclosure</b>	11.0	12.0	14.0	17.0	21.0	25.0	27.0	27.0

#### Absorption coefficient values of the internal face of the enclosure in octave bands

F [Hz]	63 Hz	125 Hz	250 Hz	500 Hz	1kHz	2kHz	4kHz	8kHz
<b>Acoustic enclosure</b>	0.15	0.40	0.80	1.00	1.00	1.00	1.00	1.00

#### Absorption coefficient values of sound source in octave bands

F [Hz]	63 Hz	125 Hz	250 Hz	500 Hz	1kHz	2kHz	4kHz	8kHz
<b>Source</b>	0.05	0.05	0.08	0.10	0.10	0.10	0.10	0.10

#### Values of the absorption coefficient of the concrete floor in octave bands where the sound source is supported

F [Hz]	63 Hz	125 Hz	250 Hz	500 Hz	1kHz	2kHz	4kHz	8kHz
<b>Floor</b>	0.03	0.03	0.03	0.03	0.03	0.03	0.03	0.03

$$L_{w \text{ engine with enclosure}} = L_{w \text{ engine without enclosure}} + 10 \log\left(\frac{4}{A}\right) - R + 10 \log S$$

$$A = \frac{S\alpha}{1 - \alpha}$$

S = enclosure surface	72 m <sup>2</sup>
S <sub>s</sub> = floor surface	18 m <sup>2</sup>
R = constant of the room	

F [Hz]	63 Hz	125 Hz	250 Hz	500 Hz	1kHz	2kHz	4kHz	8kHz
A	14.0	42.0	131.7	233.9	233.9	233.9	233.9	233.9

Now, we will calculate  $L_{w \text{ engine with enclosure}}$  from the previous formula

F [Hz]	63 Hz	125 Hz	250 Hz	500 Hz	1kHz	2kHz	4kHz	8kHz	dB
$L_{w \text{ engine without enclosure}}$ [dB]	94.1	96.2	98.8	97.5	95.4	91.3	90.0	89.7	104.3
$10 \log(4/A)$	-5.4	-10.2	-15.2	-17.7	-17.7	-17.7	-17.7	-17.7	
-R	-11.0	-12.0	-14.0	-17.0	-21.0	-25.0	-27.0	-27.0	
$10 \log S$	18.6	18.6	18.6	18.6	18.6	18.6	18.6	18.6	
$L_{w \text{ engine with enclosure}}$ [dB]	96.2	92.6	88.2	81.4	75.3	67.2	63.9	63.6	98.4

$$L_p = L_w + 10 \log\left(\frac{Q}{4\pi r^2}\right)$$

Q <sub>source</sub>	2
r = distance from the source	5 m

F [Hz]	63 Hz	125 Hz	250 Hz	500 Hz	1kHz	2kHz	4kHz	8kHz	dB
$L_p$ [dB] at 5 m from sound source	74.3	70.6	66.2	59.4	53.3	45.2	41.9	41.6	76.4

To obtain the values in dB(A), we must apply the A-weighting to the previous values.

F [Hz]	63 Hz	125 Hz	250 Hz	500 Hz	1kHz	2kHz	4kHz	8kHz
A-weighting	-26.0	-16.0	-9.0	-3.2	0.0	1.2	1.0	-1.1

F [Hz]	63 Hz	125 Hz	250 Hz	500 Hz	1kHz	2kHz	4kHz	8kHz	dB(A)
$L_p$ [dB(A)] at 5 m	48.3	54.6	57.2	56.2	53.3	46.4	42.9	40.5	62.0

It should be noted that the previous resulting values are theoretical and there are more variables such as reflections in the ground and other effects that influence

the resulting sound pressure level. Normally, safety margins of 33 dB are used, so the resulting value of this example would be 62.0 33 dB(A).

## 5.6. Noise control in pipes

### Example

Calculate the resulting sound level located 1 m from a 6 " pipe sound source, if an insulation is installed on the basis of TECH PIPE SECTION MT 4.1 with a thickness of 50 mm and a 0.8 mm thick aluminium metal protection, knowing the sound pressure level at 1 m distance with the pipe without insulation.

F [Hz]	63 Hz	125 Hz	250 Hz	500 Hz	1kHz	2kHz	4kHz	8kHz	dB
$L_p$ [dB] 1 m	78.0	82.0	80.0	79.0	78.0	78.0	77.0	73.0	87.8

The insertion losses of the pipe correspond to a classification A.

F [Hz]	63 Hz	125 Hz	250 Hz	500 Hz	1kHz	2kHz	4kHz	8kHz
IL [dB] 1 m	0.0	0.0	0.0	5.0	10.0	15.0	20.0	20.0

F [Hz]	63 Hz	125 Hz	250 Hz	500 Hz	1kHz	2kHz	4kHz	8kHz	dB
$L_p$ [dB] at 1 m with insulation	78.0	82.0	80.0	74.0	68.0	63.0	57.0	53.0	85.5

To obtain the values in dB(A), we must apply A-weighting to the previous values

F [Hz]	63 Hz	125 Hz	250 Hz	500 Hz	1kHz	2kHz	4kHz	8kHz
A-weighting	-26.0	-16.0	-9.0	-3.2	0.0	1.2	1.0	-1.1

F [Hz]	63 Hz	125 Hz	250 Hz	500 Hz	1kHz	2kHz	4kHz	8kHz	dBA
$L_p$ [dBA] At 5 m	52.0	66.0	71.0	70.8	68.0	64.2	58.0	51.9	75.9

It should be noted that the resulting sound levels correspond to an insulation installation with sufficient length to not consider the contributions to the sound pressure level by the parts furthest away from the pipe. Where it is only a part of length L that is insulated, the pipeline should be considered as a linear source, or you should introduce a series of factors that increase the sound level by the lateral contributions.



## 6. Documentation & Appendix





1.	Scientific and Technical Data .....	262
1.1	Definitions of symbols.....	262
1.2	Maximum temperature differences between surface and ambient air to prevent condensation (dew point) .....	263
1.3	Equivalent length for installation-related "thermal bridges" (ISO 12241) .....	264
1.4	Wind speeds .....	265
1.5	Medium velocities in pipes .....	266
1.6	Conversion of power units.....	266
1.7	Conversion of energy units .....	267
1.8	Specific CO <sub>2</sub> emissions of various energy sources.....	267
1.9	Emissivity of insulation systems .....	268
1.10	Average of working time at industrial plants.....	268
1.11	Mean calorific power of fuels (VDI 4608-2).....	269
1.12	Conversion of SI-units into Imperial units for thermal parameters .....	270
1.13	Water vapour resistance factor for insulation materials (ISO 10456) .....	270
1.14	Water vapour diffusion-equivalent air layer thickness (ISO 10456) .....	271
1.15	Average temperatures of countries worldwide .....	272
2.	ISOVER Industry Solutions - Technical Data Sheets .....	274
	TECH Lamella Mat .....	276
	TECH Loose Wool.....	280
	TECH Pipe Section.....	288
	U TECH Pipe Section .....	294
	CRYOLENE .....	298
	TECH Crimped .....	304
	TECH Roll.....	308
	U TECH Roll.....	312
	TECH Slab.....	316
	U TECH Slab .....	338
	TECH Telisol .....	348
	TECH Wired Mat.....	350
	U TECH Wired Mat.....	370

# Documentation & Appendix

## 1. Scientific and Technical Data

### 1.1. Definitions of symbols

Symbol	Definition	Unit
$A$	Area	$m^2$
$a^r$	Temperature factor	$K^3$
$C_r$	Radiation coefficient	$W/(m^2 \cdot K^4)$
$c_p$	Specific heat capacity at constant pressure	$kJ/(kg \cdot K)$
$D$	Diameter	$m, mm$
$d$	Thickness	$m, mm$
$H$	Height	$m$
$h$	Surface coefficient of heat transfer	$W/(m^2 \cdot 2K)$
$l$	Length	$m$
$m$	Mass	$kg$
$P$	Perimeter	$m$
$q$	Density of heat flow rate	$W/m^2$
$R$	Thermal resistance	$m^2 \cdot K/W$
$T$	Thermodynamic temperature	$K$
$U$	Thermal transmittance	$W/(m^2 \cdot 2K)$
$v$	Air velocity	$m/s$
$z, y$	Correction terms for irregular insulation-related thermal bridges	-
$z^*, y^*$	Correction terms for installation-related thermal bridges	-
$\varepsilon$	Emissivity	-
$\lambda$	Design thermal conductivity	$W/(m \cdot K)$
$\lambda_d$	Declared thermal conductivity	$W/(m \cdot K)$
$\rho$	Density	$kg/m^3$
$\sigma$	Stefan-Boltzmann constant	$W/(m^2 \cdot K^4)$
$F$	Overall conversion factor for thermal conductivity	-
$F_a$	Ageing conversion factor	-
$F_c$	Compression conversion factor	-
$F_c$	Convection conversion factor	-
$F_d$	Thickness conversion factor	-
$f_d$	Thickness conversion coefficient	-
$F_j$	Joint factor	-
$F_m$	Moisture conversion factor	-
$F_{\Delta\theta}$	Temperature difference conversion factor	-
$\Delta_\lambda$	Additional thermal conductivity due to thermal bridges, such as spacer, which are regular parts of the insulation	$W/(m \cdot K)$

## 1.2. Maximum temperature differences between surface and ambient air to prevent condensation (dew point)

Ambient air temperature [°C]	Relative air humidity [%]													
	30	35	40	45	50	55	60	65	70	75	80	85	90	95
-20	-	10.4	9.1	8.0	7.9	6.0	5.2	4.5	3.7	2.9	2.3	1.7	1.1	0.5
-15	12.3	10.8	9.6	8.3	7.3	6.4	5.4	4.6	3.8	3.1	2.5	1.8	1.2	0.6
-10	12.9	11.3	9.9	8.7	7.6	6.6	5.7	4.8	3.9	3.2	2.5	1.8	1.2	0.6
-5	13.4	11.7	10.3	9.0	7.9	6.8	5.8	5.0	4.1	3.3	2.6	1.9	1.2	0.6
0	13.9	12.2	10.7	9.3	8.1	7.1	6.0	5.1	4.2	3.5	2.7	1.9	1.3	0.7
2	14.3	12.6	11.0	9.7	8.5	7.4	6.4	5.4	4.6	3.8	3.0	2.2	1.5	0.7
4	14.7	13.0	11.4	10.1	8.9	7.7	6.7	5.8	4.9	4.0	3.1	2.3	1.5	0.7
6	15.1	13.4	11.8	10.4	9.2	8.1	7.0	6.1	5.1	4.1	3.2	2.3	1.5	0.7
8	15.6	13.8	12.2	10.8	9.6	8.4	7.3	6.2	5.1	4.2	3.2	2.3	1.5	0.8
10	16.0	14.2	12.6	11.2	10.0	8.6	7.4	6.3	5.2	4.2	3.3	2.4	1.6	0.8
12	16.5	14.6	13.0	11.6	10.1	8.8	7.5	6.3	5.3	4.3	3.3	2.4	1.6	0.8
14	16.9	15.1	13.4	11.7	10.3	8.9	7.6	6.5	5.4	4.3	3.4	2.5	1.6	0.8
16	17.4	15.5	13.6	11.9	10.4	9.0	7.8	6.6	5.4	4.4	3.5	2.5	1.7	0.8
18	17.8	15.7	13.8	12.1	10.6	9.2	7.9	6.7	5.6	4.5	3.5	2.6	1.7	0.8
20	18.1	15.9	14.0	12.3	10.7	9.3	8.0	6.8	5.6	4.6	3.6	2.6	1.7	0.8
22	18.4	16.1	14.2	12.5	10.9	9.5	8.1	6.9	5.7	4.7	3.6	2.6	1.7	0.8
24	18.6	16.4	14.4	12.6	11.1	9.6	8.2	7.0	5.8	4.7	3.7	2.7	1.8	0.8
26	18.9	16.6	14.7	12.8	11.2	9.7	8.4	7.1	5.9	4.8	3.7	2.7	1.8	0.9
28	19.2	16.9	14.9	13.0	11.4	9.9	8.5	7.2	6.0	4.9	3.8	2.8	1.8	0.9
30	19.5	17.1	15.1	13.2	11.6	10.1	8.6	7.3	6.1	5.0	3.8	2.8	1.8	0.9
35	20.2	17.7	15.7	13.7	12.0	10.4	9.0	7.6	6.3	5.1	4.0	2.9	1.9	0.9
40	20.9	18.4	16.1	14.2	12.4	10.8	9.3	7.9	6.5	5.3	4.1	3.0	2.0	1.0
45	21.6	19.0	16.7	14.7	12.8	11.2	9.6	8.1	6.8	5.5	4.3	3.1	2.1	1.0
50	22.3	19.7	17.3	15.2	13.3	11.6	9.9	8.4	7.0	5.7	4.4	3.2	2.1	1.0

## 1.3 Equivalent length for installation-related "thermal bridges" (ISO 12241)

Flanges for pressure stages PN 25 to PN 100 <sup>b</sup>		Equivalent length for given temperatures <sup>a</sup>			
		$\Delta l$ [m]			
		100 °C	250 °C	450 °C	
Uninsulated for pipes	In buildings at 20 °C	DN 50 <sup>c</sup>	3 to 5	5 to 11	9 to 15
		DN 100	4 to 7	7 to 16	13 to 16
		DN 150	4 to 9	7 to 17	17 to 30
		DN 200	5 to 11	10 to 26	20 to 37
		DN 300	6 to 16	12 to 37	25 to 57
		DN 400	9 to 16	15 to 36	33 to 56
		DN 500	10 to 16	17 to 36	37 to 57
	In the open air at 0 °C	DN 50	7 to 11	9 to 16	12 to 19
		DN 100	9 to 14	13 to 23	18 to 28
		DN 150	11 to 18	14 to 29	22 to 37
		DN 200	13 to 24	18 to 38	27 to 46
		DN 300	16 to 32	21 to 54	32 to 69
		DN 400	22 to 31	28 to 53	44 to 68
		DN 500	25 to 32	31 to 52	48 to 69
Insulated	In buildings at 20 °C and in the open air at 0 °C	DN 50 <sup>c</sup>	0.7 to 1.0	0.7 to 1.0	1.0 to 1.1
		DN 100	0.7 to 1.0	0.8 to 1.2	1.1 to 1.4
		DN 150	0.8 to 1.1	0.8 to 1.3	1.3 to 1.6
		DN 200	0.8 to 1.3	0.9 to 1.4	1.3 to 1.7
		DN 300	0.8 to 1.4	1.0 to 1.6	1.4 to 1.9
		DN 400	1.0 to 1.4	1.1 to 1.6	1.6 to 1.9
		DN 500	1.0 to 1.3	1.1 to 1.6	1.6 to 1.8
Uninsulated for pipes	In buildings at 20 °C	DN 50	9 to 15	16 to 29	27 to 39
		DN 100	15 to 21	24 to 46	42 to 63
		DN 150	1 to 28	26 to 63	58 to 90
		DN 200	21 to 35	37 to 82	73 to 108
		DN 300	29 to 51	50 to 116	106 to 177
		DN 400	36 to 60	59 to 136	126 to 206
		DN 500	46 to 76	75 to 170	158 to 267
	In the open air at 0 °C only for pressure stage PN 25	DN 50	22 to 24	27 to 34	35 to 39
		DN 100	33 to 36	42 to 52	56 to 61
		DN 150	39 to 42	50 to 68	77 to 83
		DN 200	51 to 56	68 to 87	98 to 101
		DN 300	59 to 75	90 to 125	140 to 160
		DN 400	84 to 88	106 to 147	165 to 190
		DN 500	108 to 114	134 to 182	205 to 238

Fittings for pressure stages PN 25 to PN 100 <sup>b</sup>			Equivalent length for given temperatures <sup>a</sup>		
			$\Delta l$ [m]		
			100 °C	250 °C	450 °C
<b>Insulated for pipes</b>	In buildings at 20 °C and in the open air at 0 °C	DN 50 <sup>c</sup>	4 to 5	5 to 6	6 to 7
		DN 100	4 to 5	5 to 7	6 to 7
		DN 150	4 to 6	5 to 8	6 to 9
		DN 200	5 to 7	5 to 9	7 to 10
		DN 300	5 to 9	6 to 12	7 to 13
		DN 400	6 to 9	7 to 12	8 to 15
		DN 500	7 to 11	8 to 15	9 to 19
Pipe suspensions			Supplementary value $y^*$		
<b>In buildings</b>			0.15		
<b>In the open air</b>			0.25		

a The ranges given cover the effects of the temperature and of the pressure stages.

Flanges and fittings for higher pressure stages give higher values.

b PN is the nominal pressure.

c DN is the nominal diameter.

\*  $y$  is the correction term for linear thermal transmittance caused by installation related to singular points.

## 1.4 Wind speeds

Beaufort Scale		m/s	km/h	mph
0	Calm	0 – 0.2	0 – 1	0 – 1
1	Light Air	0.3 – 1.5	1 – 5	1 – 3
2	Slight Breeze	1.6 – 3.3	6 – 11	4 – 7
3	Gentle Breeze	3.4 – 5.4	12 – 19	8 – 12
4	Moderate Breeze	5.5 – 7.9	20 – 29	13 – 18
5	Fresh Breeze	8.0 – 10.7	30 – 39	19 – 24
6	Strong Breeze	10.8 – 13.8	40 – 49	25 – 31
7	Moderate Gale	13.9 – 17.1	50 – 61	32 – 38
8	Fresh Gale	17.2 – 20.7	62 – 74	39 – 46
9	Strong Gale	20.8 – 24.4	75 – 88	47 – 54
10	Whole Gale	24.5 – 28.4	89 – 102	55 – 63

## 1.5 Medium velocities in pipes

Service	Velocity [m/s]	Liquid fluid	Velocity [m/s]
Average liquid process	1.2 - 2.0	Ammonia, liquid	1.8
Pump suction, supercooled fluid	0.3 - 1.5	Benzene	1.8
Pump suction, boiling fluid	0.2 - 0.9	Bromine	1.2
Boiler feed water	1.2 - 2.4	Calcium chloride	1.2
Gravity liquid drain lines	0.5 - 1.2	Carbon tetrachloride	1.8
Liquid to reboiler (no pump)	0.6 - 2.1	Chlorine, dry liquid	1.5
Vapour-liquid mixture out of reboiler	4.6 - 9.1	Chloroform	1.8
Vapour to condenser	4.6 - 24.4	Ethylene dibromide	1.2
Gravity separator flows	0.2 - 0.5	Ethylene dichloride	1.8
District heating	1.8 - 2.1	Ethylene glycol	1.8
Steam piping (saturated steam)	20 - 30	Hydrochloric acid, liquid	1.5
Steam piping (medium-high pressure steam)	40 - 60	Methyl chloride, liquid	1.8
		Oils, lubricating	1.8
		Perchloroethylene	1.8
		Propylene glycol	1.5
		Sodium chloride solution	1.5

## 1.6 Conversion of power units

Unit	W	kW	MW	kWh/a	GJ/a
1W = 1 J/s	1	0.001	$10^{-6}$	8.76	0.0315
kW	1,000	1	$10^{-3}$	8,760	31.54
MW	$10^6$	$10^3$	1	$8.76 \cdot 10^6$	$31.54 \cdot 10^3$
kWh/a	0.1142	$11.2 \cdot 10^{-6}$	$114.2 \cdot 10^{-9}$	1	$3.6 \cdot 10^{-3}$
GJ/a	31.7	0.0317	$31.7 \cdot 10^{-6}$	278	1
1 TCE	929	0.929	$0.929 \cdot 10^{-3}$	8,139	29.3

1 TCE = 1 t coal equivalent

## 1.7 Conversion of energy units

Unit	kJ	MJ	GJ	TJ	PJ	kWh	MWh	GWh	TWh	PWh	TCE	TOE
<b>kJ</b>	1	1.00 <sup>-3</sup>	1.00 <sup>-6</sup>	1.00 <sup>-9</sup>	1.00 <sup>-12</sup>	2.78 <sup>-4</sup>	2.78 <sup>-7</sup>	2.78 <sup>-10</sup>	2.78 <sup>-13</sup>	2.78 <sup>-16</sup>	3.41 <sup>-8</sup>	2.39 <sup>-8</sup>
<b>MJ</b>	1,000	1	1.00 <sup>-3</sup>	1.00 <sup>-6</sup>	1.00 <sup>-9</sup>	2.78 <sup>-1</sup>	2.78 <sup>-4</sup>	2.78 <sup>-7</sup>	2.78 <sup>-10</sup>	2.78 <sup>-13</sup>	3.41 <sup>-5</sup>	2.39 <sup>-5</sup>
<b>GJ</b>	1.00 <sup>6</sup>	1,000	1	0.001	1.00 <sup>-6</sup>	2.78 <sup>2</sup>	2.78 <sup>-1</sup>	2.78 <sup>-4</sup>	2.78 <sup>-7</sup>	2.78 <sup>-10</sup>	3.41 <sup>-2</sup>	2.39 <sup>-2</sup>
<b>TJ</b>	1.00 <sup>9</sup>	1.00 <sup>6</sup>	1,000	1	0.001	2.78 <sup>5</sup>	2.78 <sup>2</sup>	2.78 <sup>-1</sup>	2.78 <sup>-4</sup>	2.78 <sup>-7</sup>	3.41	2.39
<b>PJ</b>	1.00 <sup>12</sup>	1.00 <sup>9</sup>	1.00 <sup>6</sup>	1,000	1	2.78 <sup>8</sup>	2.78 <sup>5</sup>	2.78 <sup>2</sup>	2.78 <sup>-1</sup>	2.78 <sup>-4</sup>	3.41 <sup>4</sup>	2.39 <sup>4</sup>
<b>kWh</b>	3.60 <sup>3</sup>	3.60	3.60 <sup>-3</sup>	3.60 <sup>-6</sup>	3.60 <sup>-9</sup>	1	0.001	1.00 <sup>-6</sup>	1.00 <sup>-9</sup>	1.00 <sup>-12</sup>	1.23 <sup>-4</sup>	8.60 <sup>-5</sup>
<b>MWh</b>	3.60 <sup>6</sup>	3.60 <sup>3</sup>	3.60	3.60 <sup>-3</sup>	3.60 <sup>-6</sup>	1,000	1	0.001	1.00 <sup>-6</sup>	1.00 <sup>-9</sup>	1.23 <sup>-1</sup>	8.60 <sup>-2</sup>
<b>GWh</b>	3.60 <sup>9</sup>	3.60 <sup>6</sup>	3.60 <sup>3</sup>	3.60	3.60 <sup>-3</sup>	1.00 <sup>6</sup>	1,000	1	1.00 <sup>-3</sup>	1.00 <sup>-6</sup>	1.23 <sup>2</sup>	8.60
<b>TWh</b>	3.60 <sup>12</sup>	3.60 <sup>9</sup>	3.60 <sup>6</sup>	3.60 <sup>3</sup>	3.60	1.00 <sup>9</sup>	1.00 <sup>6</sup>	1,000	1	1.00 <sup>-3</sup>	1.23 <sup>5</sup>	8.60 <sup>4</sup>
<b>PWh</b>	3.60 <sup>+15</sup>	3.60 <sup>12</sup>	3.60 <sup>9</sup>	3.60 <sup>6</sup>	3.60 <sup>3</sup>	1.00 <sup>12</sup>	1.00 <sup>9</sup>	1.00 <sup>6</sup>	1,000	1	1.23 <sup>8</sup>	8.60 <sup>7</sup>
<b>TCE</b>	2.93 <sup>7</sup>	2.93 <sup>4</sup>	2.93	2.93 <sup>-2</sup>	2.93 <sup>-5</sup>	8.13 <sup>3</sup>	8.13E+00	8.13 <sup>-3</sup>	8.13 <sup>-6</sup>	8.13 <sup>-9</sup>	1	0.70
<b>TOE</b>	4.19 <sup>7</sup>	4.19 <sup>4</sup>	4.19	4.19 <sup>-2</sup>	4.19 <sup>-5</sup>	1.16 <sup>4</sup>	1.16	1.16 <sup>-2</sup>	1.16 <sup>-5</sup>	1.16 <sup>-8</sup>	1.43 <sup>0</sup>	1

1 TCE = 1 t coal equivalent

1 TOE = 1 t oil equivalent

## 1.8 Specific CO<sub>2</sub> emissions of various energy sources

Fuel	t CO <sub>2</sub> / GWh = g CO <sub>2</sub> / kWh
Hard coal	342
Lignite dust, Rhineland	353
Raw lignite, Rhineland	410
Light heating oil	266
Heavy heating oil	281
Benzine	259
Natural gas	202
Butane	230
Propane	234
Domestic waste	162

## 1.9 Emissivity of insulation systems

Surface of insulating system	New	Aged
Alu-stucco	0.03	
Aluminium (AlMg <sub>3</sub> , AlMg <sub>2</sub> , Mn <sub>0,8</sub> )	0.05	0.07
Aluminium, oxidized		0.13
Alu-zinc	0.06 – 0.16	0.24 – 0.28
Galvanized steel sheet	0.26 – 0.30	0.32 – 0.44
Stainless austenitic steel sheet	0.10 – 0.15	
Plastic-coated sheet	0.90	
Painted sheet	0.90	0.90
Cellular glass	0.90	0.90
Flexible elastomeric foam	0.93	0.93
Plastic cladding	0.90	0.90
Rust		0.90

## 1.10 Average working time at industrial plants

Industry	Annual operation time [h/a]	Industry	Annual operation time [h/a]
Lignite plant	7,500	Process heat (PH) paper	8,000
Hardcoal plant	7,500	PH mineral oil industry	8,000
Natural gas, combined gas and steam	7,500	PH chemical industry	8,000
Natural gas turbines	1,000	PH food industry	7,000
CHP (combined heat and power) paper	8,000	PH sugar	3,500
CHP mineral oil industry	8,000	Heat, hospitals	7,000
CHP chemical industry	8,000	Heat, capital goods sector	6,000
CHP food industry	7,000	Heat, other industries	7,000
CHP sugar	3,500	Mineral oil industry	8,000
CHP hospitals	7,000	Coke oven plant	8,300
CHP capital goods sector	6,000	Sintering plant	8,300
CHP other industries	7,500	Iron producing and processing	8,300
CHP district heating, public	6,000	Cement	7,500
Natural gas compressor, transport	4,200	Lime in lime industry	7,500
Natural gas compressor	3,100	Lime in sugar industry	2,500
Heat supply station, public district heating	2,500	Glass	8,000

## 1.11 Mean calorific power of fuels (VDI 4608-2)

Energy source	Quantity unit (QU)	Inferior calorific value (MJ/QU)
<b>Solids</b>		
Hard coal	kg	30.10
Hard coal coke	kg	28.70
Hard coal briquettes	kg	31.40
Lignite	kg	9.20
Lignite briquettes	kg	19.60
Lignite coke	kg	29.90
Dry and dusty coal	kg	22.00
Fuel wood	m <sup>3</sup>	6,480.00
Petrol coke	kg	31.10
<b>Fluids</b>		
Raw oil	m <sup>3</sup>	33,306.00 – 42,700.00
Diesel	m <sup>3</sup>	35,600.00
Heating oil, light	m <sup>3</sup>	36,000.00
Heating oil, heavy	m <sup>3</sup>	37,500.00
Liquefied gas (LPG)	m <sup>3</sup>	23,800.00 – 26,300.00
<b>Gases</b>		
Refinery gas	kg	45.90
Coke oven gas	m <sup>3</sup> (i-N)*	16.00
Furnace gas	m <sup>3</sup> (i-N)	4.20
Natural gas, low	m <sup>3</sup> (i-N)	31.70
Natural gas, high	m <sup>3</sup> (i-N)	36.00
Petroleum gas	m <sup>3</sup> (i-N)	40.30
Mine gas	m <sup>3</sup> (i-N)	16.00
Sewage gas	m <sup>3</sup> (i-N)	16.00

\* normal conditions ( $P_n = 1.01325 \text{ bar}$ ,  $T_n = 273.15 \text{ K}$ )

### 1.12 Conversion of SI-units into Imperial units for thermal parameters

Symbol	Quantity	SI - unit	Imperial units
$Q$	Heat, energy	J	1 BTU = 1,055.06 J
$Q$	Heat flow	W/m <sup>2</sup>	1 BTU/(sq.ft.hr.) = 3.1546 W/m <sup>2</sup>
$\lambda$	Thermal conductivity	W/(m·K)	1 BTU/(ft.hr.°F) = 1.7307 W/(m·K) 1 BTU in/(sq.ft.hr.°F) = 0.1442 W/(m·K) 1 BTU/(in.hr.°F) = 20.7688 W/(m·K)
$R$	Thermal resistance	m <sup>2</sup> ·K/W	(sq.ft.hr.°F)/1 BTU = 0.1761 m <sup>2</sup> K/W
$h$	Surface coefficient of heat transfer	W/(m <sup>2</sup> ·K)	1 BTU / (sq.ft.hr.°F) = 5.6783 W/(m <sup>2</sup> ·K)
$C_p$	Specific heat capacity at constant pressure	kJ/(kg·K)	1 BTU/(lb.°F) = 4.1868 kJ/(kg·K)
$C_r$	Radiation coefficient	W/(m <sup>2</sup> ·K <sup>4</sup> )	1 BTU / (sq.ft.hr.°R <sup>4</sup> ) = 33.156 kJ/(m <sup>2</sup> ·K <sup>4</sup> )

### 1.13 Water vapour resistance factor for insulation materials (ISO 10456)

Material	Water vapour resistance factor $Q$	
	dry	wet
Expanded polystyrene	60.00	60.00
Extruded polystyrene foam	150.00	150.00
Polyurethane foam, rigid	60.00	60.00
Mineral wool	1.00	1.00
Phenolic foam	50.00	50.00
Cellular glass	∞	∞
Perlite board	5.00	5.00
Expanded cork	10.00	5.00
Wood wool board	5.00	3.00
Wood fibreboard	5.00	3.00
Urea-formaldehyde foam	2.00	2.00
Spray applied polyurethane foam	60.00	60.00
Loose-fill mineral wool	1.00	1.00

## 1.14 Water vapour diffusion-equivalent air layer thickness (ISO 10456)

Product / Material	Water vapour diffusion-equivalent air layer thickness $s_d$ [m]
Polyethylene 0.15 mm	50.00
Polyethylene 0.25 mm	100.00
Polyester film 0.2 mm	50.00
PVC foil	30.00
Aluminium foil 0.05 mm	1,500.00
PE-foil (stapled) 0.15 mm	8.00
Bituminous paper 0.1 mm	2.00
Aluminium paper 0.4 mm	10.00
Breather membrane	0.20
Paint, emulsion	0.10
Paint, gloss	3.00
Vinyl wallpaper	2.00

*The water vapour diffusion-equivalent air layer thickness of a product is the thickness of a motionless air layer with the same water vapour resistance as the product. It is an expression of resistance to diffusion of water vapour.*

## 1.15 Average temperatures of countries worldwide

Country	Average temperature [°C]	Country	Average temperature [°C]
Afghanistan	12.60	Dominica	22.35
Albania	11.40	Dominican Republic	24.55
Algeria	22.50	Ecuador	21.85
Andorra	7.60	Egypt	22.10
Angola	21.55	El Salvador	24.45
Antigua and Barbuda	26.00	Equatorial Guinea	24.55
Argentina	14.80	Eritrea	25.50
Armenia	7.15	Estonia	5.10
Australia	21.65	Ethiopia	22.20
Austria	6.35	Federated States of Micronesia	25.85
Azerbaijan	11.95	Fiji	24.40
Bahamas	24.85	Finland	1.70
Bahrain	27.15	France	10.70
Bangladesh	25.00	Gabon	25.05
Barbados	26.00	Gambia	27.50
Belarus	6.15	Georgia	5.80
Belgium	9.55	Germany	8.50
Belize	25.30	Ghana	27.20
Benin	27.55	Greece	15.40
Bhutan	7.40	Grenada	26.65
Bolivia	21.55	Guatemala	23.45
Bosnia and Herzegovina	9.85	Guinea	25.70
Botswana	21.50	Guinea-Bissau	26.75
Brazil	24.95	Guyana	26.00
Brunei	26.85	Haiti	24.90
Bulgaria	10.55	Honduras	23.50
Burkina Faso	28.25	Hungary	9.75
Burundi	19.80	Iceland	1.75
Cambodia	26.80	India	23.65
Cameroon	24.60	Indonesia	25.85
Canada	-5.35	Iran	17.25
Cape Verde	23.30	Iraq	21.40
Central African Republic	24.90	Ireland	9.30
Chad	26.55	Israel	19.20
Chile	8.45	Italy	13.45
China	6.95	Ivory Coast	26.35
Colombia	24.50	Jamaica	24.95
Comoros	25.55	Japan	11.15
Costa Rica	24.80	Jordan	18.30
Croatia	10.90	Kazakhstan	6.40
Cuba	25.20	Kenya	24.75
Cyprus	18.45	Kiribati	28.20
Czech Republic	7.55	Kuwait	25.35
Democratic Republic of the Congo	24.00	Kyrgyzstan	1.55
Denmark	7.50	Laos	22.80
Djibouti	28.00	Latvia	5.60

Country	Average temperature [°C]
Lebanon	16.40
Lesotho	11.85
Liberia	25.30
Libya	21.80
Liechtenstein	5.65
Lithuania	6.20
Luxembourg	8.65
Macedonia	9.80
Madagascar	22.65
Malawi	21.90
Malaysia	25.40
Maldives	27.65
Mali	28.25
Malta	19.20
Marshall Islands	27.40
Mauritania	27.65
Mauritius	22.40
Mexico	21.00
Moldova	9.45
Monaco	13.55
Mongolia	-0.70
Montenegro	10.55
Morocco	17.10
Mozambique	23.80
Myanmar	13.05
Namibia	19.95
Nepal	8.10
Netherlands	9.25
New Zealand	10.55
Nicaragua	24.90
Niger	27.15
Nigeria	26.80
North Korea	5.70
Norway	1.50
Oman	25.60
Pakistan	20.20
Palau	27.60
Panama	25.40
Papua New Guinea	25.25
Paraguay	23.55
Peru	19.60
Philippines	25.85
Poland	7.85
Republic of the Congo	24.55
Romania	8.80
Russia	-5.10
Rwanda	17.85
Saint Kitts and Nevis	24.50
Saint Lucia	25.50

Country	Average temperature [°C]
Saint Vincent and the Grenadines	26.80
Samoa	26.70
San Marino	11.85
Saudi Arabia	24.65
Senegal	27.85
Serbia	10.55
Seycheles	27.15
Sierra Leone	26.05
Singapore	26.45
Slovakia	6.80
Slovenia	8.90
Solomon Islands	25.65
Somalia	27.05
South Africa	17.75
South Korea	11.50
Spain	13.30
Sri Lanka	26.95
Sudan	26.90
Suriname	25.70
Swaziland	21.40
Sweden	2.10
Switzerland	5.50
Syria	17.75
Sao Tome and Principe	23.75
Tajikistan	2.00
Tanzania	22.35
Thailand	26.30
Timor-Leste	25.25
Togo	27.15
Tonga	25.25
Trinidad and Tobago	25.75
Tunisia	19.20
Turkey	11.10
Turkmenistan	15.10
Tuvalu	28.00
Uganda	22.80
Ukraine	8.30
United Arab Emirates	27.00
United Kingdom	8.45
United States	8.55
Uruguay	17.55
Uzbekistan	12.05
Vanuatu	23.95
Venezuela	25.35
Vietnam	24.45
Yemen	23.85
Zambia	21.40
Zimbabwe	21.00



## 2. ISOVER Industry Solutions – Technical Data Sheets

ISOVER has worked closely with industrial process designers, operators and contractors to develop a range of industry solutions that meet any insulation requirement. The ISOVER TECH products range is specially designed to offer unique insulation solutions for thermal, fire, sound and corrosion protection for any

industrial application. No matter if in power generation, oil & gas or process industry, from cryogenic tanks to high-temperature boilers or special equipment in nuclear plants. Below you will find the Technical Data Sheets of our Isover Insulation Solutions specially engineered for industry applications so far.

<b>TECH Lamella Mat</b> .....	<b>276</b>	<b>TECH Slab</b> .....	<b>316</b>
TECH Lamella Mat MT 2.0 .....	276	TECH Slab 2.0 Alu1/V1.....	316
TECH Lamella Mat MT 2.1 Alu2.....	278	TECH Slab 2.1 V1/V2.....	318
<b>TECH Loose Wool</b> .....	<b>280</b>	TECH Slab 3.0.....	320
TECH Loose Wool.....	280	TECH Slab 3.0 G1.....	322
TECH Loose Wool EX .....	282	TECH Slab MT 2.2 V2 .....	324
TECH Loose Wool HT .....	284	TECH Slab MT 3.0.....	326
TECH Loose Wool QN .....	286	TECH Slab MT 3.1 Alu2/V1.....	328
<b>TECH Pipe Section</b> .....	<b>288</b>	TECH Slab MT 4.0.....	330
TECH Pipe Section MT 4.0 .....	288	TECH Slab MT 4.1 Alu2/V1.....	332
TECH Pipe Section MT 4.1.....	290	TECH Slab MT 5.1.....	334
TECH Pipe Section MT 4.2.....	292	TECH Slab HT 6.1.....	336
<b>U TECH Pipe Section</b> .....	<b>294</b>	<b>U TECH Slab</b> .....	<b>338</b>
U TECH Pipe Section MT 4.0.....	294	U TECH Slab 2.0 Alu1/V1/V2/G1.....	338
U TECH Pipe Section Mat MT 7.0 G1.....	296	U TECH Slab MT 3.0 Alu1/V1/V2 .....	340
<b>CRYOLENE</b> .....	<b>298</b>	U TECH Slab MT 3.1 Alu1/V1/V2 .....	342
CRYOLENE 681 AA & VV .....	298	U TECH Slab MT 5.0 Alu1/V1/V2 .....	344
CRYOLENE 682 AA & VV .....	300	U TECH Slab MT 6.0 Alu1/V1/G1 .....	346
CRYOLENE 684 AA & VV .....	302	<b>TECH Telisol</b> .....	<b>348</b>
<b>TECH Crimped</b> .....	<b>304</b>	TECH Telisol 5.0 QN.....	348
TECH Crimped Roll 1.0 Alu1.....	304	<b>TECH Wired Mat</b> .....	<b>350</b>
TECH Crimped Roll 2.0 Alu1 .....	306	TECH Wired Mat MT 3.0 Alu1/X/X-X.....	350
<b>TECH Roll</b> .....	<b>308</b>	TECH Wired Mat MT 3.1 Alu1/X/X-X.....	352
TECH Roll 2.0 Alu2.....	308	TECH Wired Mat MT 4.0 Alu1/X/X-X.....	354
TECH Roll 3.0.....	310	TECH Wired Mat MT 4.1 Alu1/X/X-X .....	356
<b>U TECH Roll</b> .....	<b>312</b>	TECH Wired Mat MT 4.2 X/X-X .....	358
U TECH Roll 2.0 Alu1/V1/V2.....	312	TECH Wired Mat MT 5.0 Alu1/X/X-X.....	360
U TECH Roll MT 4.0 Alu1/V1/V2 .....	314	TECH Wired Mat MT 5.1 Alu1/X/X-X.....	362
		TECH Wired Mat MT 5.2 X/X-X .....	364
		TECH Wired Mat MT 6.1 X/X-X .....	366
		TECH Wired Mat HT 6.1.....	368
		<b>U TECH Wired Mat</b> .....	<b>370</b>
		U TECH Wired Mat MT 4.0 Alu1/V1/X/X-X .....	370
		U TECH Wired Mat MT 5.0 Alu1/V1/X/X-X .....	372
		U TECH Wired Mat MT 6.0 Alu1/V1/X/X-X .....	374



# TECH Lamella Mat MT 2.0

## Compression-resistant flexible glass mineral wool lamella mats

TECH Lamella Mat 2.0 is the flexible-to-use and time-saving alternative for the insulation of big diameter pipes, tanks and vessels, exhaust ducts and stacks or other curved structures. With a compressive strength (CS 10) of  $\geq 10$  kPa they can usually be installed without support structures independent of the pipe diameter ( $> DN 400$  recommended). TECH Lamella Mat 2.0 is offering classic-plus thermal performance for a maximum service temperature up to 400 °C. TECH Lamella Mat 2.0 is faced with a reinforced aluminum foil acting as vapour barrier and improves mechanical strength for easy and fast bending.



### Mechanical resistance

Compression-resistant lamella mat with vertical fiber structure



### Thermal insulation

Classic-Plus thermal insulation performance for service temperatures up to 400 °C



### Fast installation

Flexibility, lightweight and compressibility helps to handle and install the product easier and faster



### Sound insulation

The ability of mineral wool to act as a spring results in reducing vibration and noise emissions in industrial processes



### Lightweight

Lightweight solution with up to 50 % weight savings compared to standard insulation solutions



### Sound absorption

Up to 95 % of sound energy absorbed due to optimal longitudinal air flow resistance and uniform porosity values



### Thermal Efficiency Indicator

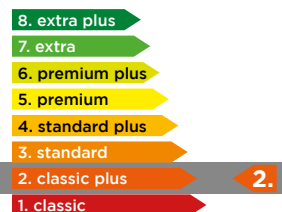



## Compression-resistant flexible glass mineral wool lamella mats

Characteristic	Symbol	Unit	Quantities and declared values						Standard
<b>Thermal behaviour Max. service temp.</b>	T	[°C]	400 (under 500 Pa)						EN 14706
<b>Thermal conductivity</b>	T	[°C]	50	100	150	200	300	400	EN 12667 ISO 13787
		[W/(m•K)]	0.045	0.054	0.065	0.079	0.120	0.180	
<b>Specific thermal capacity</b>	c	[kJ/(kg•K)]	1.03						ISO 10456
<b>Fire protection / Behaviour in fire</b>	-	-	Euroclass A2-s1, d0						EN 13501-1
<b>Compressive strength</b>	-	-	CS(10)10						-
<b>Chemical behaviour</b>	-	-	AS-Quality Leachable chloride content less than 10 ppm (CL10) Do not contribute to corrosion of stainless steel Produced without addition of silicone						AGI Q 132 EN 13468 ASTM C795
<b>Application field</b>	-	-	Product for use in technical applications, such as big diameter pipes, tanks and vessels, exhaust ducts and stacks or others curved structures						EN 14303
<b>Material</b>	-	-	Glass mineral wool, with general orientation of the fibers perpendicular to product's surface With quality marks EUCEB and RAL by the Gütegemeinschaft Mineralwolle e. V., unrisky regarding health according to German decree on dangerous substances, decree on prohibition of chemicals and to regulation EC No 1272/2008 Note Q						CINI 2.1.05
<b>Facing</b>	-	-	Faced on one side with reinforced aluminium						-
<b>Quality management</b>	-	-	CE-marked according to EN 14303 Quality control according to VDI 2055 ISOVER is certified according to EN ISO 9001 and EN ISO 14001						EN 14303 VDI 2055 EN ISO 9001 EN ISO 14001
<b>Miscellaneous</b>	-	-	Insulating material identification number: 10.03.02.99.05 MW-EN 14303-T4-ST(+)-400-CS(10)10-MV2-CL10						AGI Q 132 EN 14303

Delivery form: Standard dimensions / packaging information*				
<b>Thickness d [mm]</b>	50	60	80	100
<b>Width b [mm]</b>	600	600	600	600
<b>Length l [mm]</b>	5,000	4,000	3,000	2,500
<b>m<sup>2</sup>/pack</b>	6.00	4.80	3.60	3.00
<b>Rolls/pack</b>	2	2	2	2

\* all dimensions require minimum order quantities / other dimensions on request

[www.isover-technical-insulation.com](http://www.isover-technical-insulation.com)

The technical information corresponds to our present state of knowledge and experience at the date of printing (see imprint). But no legal guarantee can be given, unless it has been explicitly agreed. The state of experience and knowledge is developing continuously. Please see to it that you always use the latest edition of this information. The described product applications do not take special circumstances in consideration. Please verify whether our products are appropriate for the concrete application. For further information please contact our Isover sales offices. We deliver only according to our terms of trade and terms of delivery.

SAINT-GOBAIN ISOVER · "Les Miroirs" · 18, avenue d'Alsace · 92400 Courbevoie · France



# TECH Lamella Mat MT 2.1 Alu2

## Compression-resistant stone mineral wool lamella mats

TECH Lamella Mat 2.1 is the flexible-to-use and time-saving alternative for the insulation of big diameter pipes, tanks and vessels, exhaust ducts and stacks or other curved structures. They can usually be installed without support structures independent of the pipe diameter (> DN 400 recommended). TECH Lamella Mat 2.1 is offering classic-plus thermal performance for a maximum service temperature up to 250 °C. TECH Lamella Mat 2.1 Alu2 is faced with a reinforced aluminium foil acting as vapour barrier and improves mechanical strength for easy and fast bending.



### Mechanical resistance

Compression-resistant lamella mat with vertical fiber structure



### Fast installation

Flexibility, lightweight and compressibility helps to handle and install the product easier and faster



### Thermal insulation

Classic-Plus thermal insulation performance for service temperatures up to 250 °C



### Sound absorption

Up to 95 % of sound energy absorbed due to optimal longitudinal air flow resistance and uniform porosity values

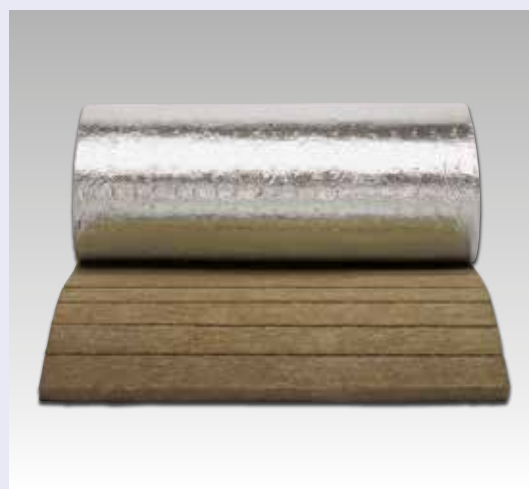

### Thermal Efficiency Indicator

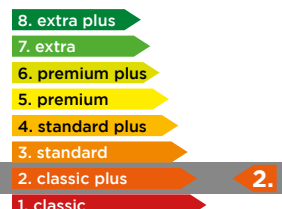



## Compression-resistant stone mineral wool lamella mats

Characteristic	Symbol	Unit	Quantities and declared values						Standard
<b>Thermal behaviour</b> Max. service temp.	T	[°C]	250 (under 500 Pa)						EN 14706
<b>Thermal conductivity</b>	T	[°C]	10	50	100	150	200	250	EN 12667 ISO 13787
		[W/(m•K)]	0.040	0.046	0.056	0.069	0.084	0.103	
<b>Specific thermal capacity</b>	c	[kJ/(kg•K)]	1.03						ISO 10456
<b>Fire protection / Behaviour in fire</b>	-	-	Euroclass A2-s1, d0						EN 13501-1
<b>Chemical behaviour</b>	-	-	AS-Quality Do not contribute to corrosion of stainless steel No short term water absorption by partial immersion (WS1)						AGI Q 132 ASTM C795 EN 1609
<b>Application field</b>	-	-	Product for use in technical applications, such as big diameter pipes, tanks and vessels, exhaust ducts and stacks or others curved structures						EN 14303
<b>Material</b>	-	-	Stone mineral wool, with general orientation of the fibers perpendicular to product's surface With quality marks EUCEB, unrisky regarding health according to regulation EC No 1272/2008 Note Q						CINI 2.2.05
<b>Facing</b>	-	-	On request: Reinforced aluminium facing (Alu2)						-
<b>Quality management</b>	-	-	CE-marked according to EN 14303 ISOVER is certified according to EN ISO 9001 and EN ISO 14001						EN 14303 EN ISO 9001 EN ISO 14001
<b>Miscellaneous</b>	-	-	MW-EN 14303-T4-ST(+)-250-WS1						EN 14303

Delivery form: Standard dimensions / packaging information*								
<b>Thickness d [mm]</b>	20	30	40	50	60	70	80	100
<b>Width b [mm]</b>	1,000	1,000	1,000	1,000	1,000	1,000	1,000	1,000
<b>Length l [mm]</b>	8,000	5,000	4,000	3,000	3,000	4,000	2,000	2,300
<b>m<sup>2</sup>/roll</b>	8.00	5.00	4.00	3.00	3.00	4.00	2.00	2.30
<b>m<sup>2</sup>/pallet</b>	160.00	100.00	80.00	60.00	63.00	48.00	40.00	41.40
<b>Rolls/pack</b>	1	1	1	1	1	1	1	1
<b>Packs/pallet</b>	20	20	20	20	21	12	20	18

\* all dimensions require minimum order quantities / other dimensions on request



# TECH Loose Wool

## Loose glass mineral wool roll for industry equipment

TECH Loose Wool is a light weight lightly-bonded glass mineral wool roll for insulation of inaccessible cavities, complicated confined surfaces or dead spaces. TECH Loose Wool can be flexibly used for service temperatures up to 400 °C. The thermal performance will be dependent on the stuffing density and direction of the fibers towards heat source.



### Lightweight

Lightweight solution with up to 50 % weight savings compared to standard insulation solutions



### Fire reaction

Non-combustible, Euroclass A1 for effective fire protection on industry sites



### Nuclear plant quality

Certified for use in nuclear applications



### High flexibility

Flexible to use lightly bonded glass wool for filling of joints and dead spaces



### Improved logistics

Transport and storage savings with up to 80 % more material per pallet than standard solutions



ISOVER-TDS-Industry-INT-ENG-TECH Loose Wool 2019-09





## Loose glass mineral wool roll for industry equipment

Characteristic	Symbol	Unit	Quantities and declared values									Standard
<b>Thermal behaviour</b>	T	[°C]	400 (under 500 Pa)									EN 14706
<b>Thermal conductivity*</b>	T	[°C]	-120	-80	-30	0	50	100	150	200	300	EN 12667 ISO 13787
		[W/(m•K)]	0.017	0.022	0.027	0.031	0.038	0.045	0.052	0.062	0.083	
<b>Fire protection / Behaviour in fire</b>	-	-	Non combustible; Euroclass A1									EN 13501-1
			Fire Spread Index = 0; Smoke Development Index < 20									ASTM E84
<b>Chemical behaviour</b>	-	-	AS-Quality Do not contribute to corrosion of stainless steel Produced without addition of silicone									AGI Q 132 ASTM C795
<b>Application field</b>	-	-	Product for use in technical applications, such as inaccessible cavities, complicated confined surfaces or dead spaces. Certified for use in nuclear applications (PMUC 09-0007)									EN 14303 PMUC 09-0007
<b>Material</b>	-	-	Loose glass mineral wool roll without binder With quality marks EUCEB and RAL by the Gütegemeinschaft Mineralwolle e. V., unriskey regarding health according to German decree on dangerous substances, decree on prohibition of chemicals and to regulation EC No 1272/2008 Note Q									CINI 2.1.04
<b>Quality management</b>	-	-	CE-marked according to EN 14303 ISOVER is certified according to EN ISO 9001 and EN ISO 14001									EN 14303 EN ISO 9001 EN ISO 14001
<b>Miscellaneous</b>	-	-	Storage: Bags to be stored indoors in a dry and clean place away from source of humidity									EN 14303
<b>Delivery form</b>	-	-	Packaging: Loose wool in bags of 10 kg Please contact your local ISOVER dealer All dimensions require minimum order quantities									-

\* Indicative values for a homogeneous density of around 60 kg/m<sup>3</sup>. Values may vary according to density and stuffing quality.



# TECH Loose Wool EX

## Inorganic loose stone mineral wool for explosion risk industry applications

TECH Loose Wool EX is the lightly-bonded stone mineral wool roll with almost no organic content for insulation in explosion risk areas e.g. when in contact with liquid oxygen such as in cold boxes, air separation units etc. inline with application standards as AGI Q 118 and specifications of industrial gas providers e.g. Linde, Air Liquide, Air Products. The thermal performance will be dependent on the stuffing density and direction of the fibers towards the heat flow.



### Explosion risk solution

Especially designed for use in explosion risk areas when in contact with liquid oxygen



### High service temperatures

Especially designed for high service temperatures up to 700°C



### Fire reaction

Non-combustible, Euroclass A1 for effective fire protection on industry sites



### High flexibility

Flexible to use non-bonded glass wool for filling of joints and dead spaces



### Improved logistics

Transport and storage savings with up to 80 % more material per pallet than standard solutions





## Inorganic loose stone mineral wool for explosion risk industry applications

Characteristic	Symbol	Unit	Quantities and declared values						Standard
<b>Thermal behaviour</b>	T	[°C]	Operating temperature range -200 °C until +700 °C						EN 14706
<b>Thermal conductivity*</b>	T	[°C]	50	100	150	200	300	400	EN 12667
		[W/(m•K)]	0.041	0.046	0.054	0.063	0.073	0.082	ISO 13787
<b>Specific thermal capacity</b>	c	[kJ/(kg•K)]	1.03						ISO 10456
<b>Fire protection / Behaviour in fire</b>	-	-	Non combustible; Euroclass A1						EN 13501-1
			Fire Spread Index = 0; Smoke Development Index = 0						ASTM E84
<b>Chemical behaviour</b>	-	-	AS-Quality Do not contribute to corrosion of stainless steel Do not contain silicone						AGI Q 132 ASTM C795 EN 1609
<b>Application field</b>	-	-	Product for use in technical applications, such as inaccessible cavities, complicated confined surfaces or dead spaces						EN 14303
<b>Material</b>	-	-	Loose stone mineral wool without binder With quality marks EUCEB, unrisky regarding health according to regulation EC No 1272/2008 Note Q						CINI 2.2.04
<b>Quality management</b>	-	-	CE-marked according to EN 14303 ISOVER is certified according to EN ISO 9001 and EN ISO 14001						EN 14303 EN ISO 9001 EN ISO 14001
<b>Miscellaneous</b>	-	-	Storage: Bags to be stored indoors in a dry and clean place away from source of humidity						EN 14303
<b>Delivery form</b>	-	-	Please contact your local ISOVER dealer All dimensions require minimum order quantities						-

\* Indicative values for a homogeneous density of around 100 kg/m<sup>3</sup>. Values may vary according to density and stuffing quality.



# TECH Loose Wool HT

## Loose stone mineral wool for high-temperature industry applications

TECH Loose Wool HT is the lightly-bonded stone mineral wool roll for insulation of dead spaces, joints, industrial mattresses fillings or other areas where preformed insulation materials cannot be used. TECH Loose Wool HT can be flexibly used for service temperatures up to 700 °C. The thermal performance will be dependent on the stuffing density and direction of the fibers towards heat source.



### High service temperatures

Especially designed for high service temperatures up to 700°C



### Fire reaction

Non-combustible, Euroclass A1 for effective fire protection on industry sites



### Nuclear plant quality

Certified for use in nuclear applications



### High flexibility

Flexible to use lightly bonded glass wool for filling of joints and dead spaces



### Improved logistics

Transport and storage savings with up to 80 % more material per pallet than standard solutions



ISOVER-TDS-Industry-INT-ENG-TECH Loose Wool HT 2019-09





## Loose stone mineral wool for high-temperature industry applications

Characteristic	Symbol	Unit	Quantities and declared values						Standard
<b>Thermal behaviour</b>	T	[°C]	Operating temperature range -200 °C until +700 °C						EN 14706
<b>Thermal conductivity*</b>	T	[°C]	50	100	150	200	300	400	EN 12667 ISO 13787
		[W/(m•K)]	0.041	0.046	0.054	0.063	0.073	0.082	
<b>Specific thermal capacity</b>	c	[kJ/(kg•K)]	1.03						ISO 10456
<b>Fire protection / Behaviour in fire</b>	-	-	Non combustible; Euroclass A1						EN 13501-1
			Fire Spread Index = 0; Smoke Development Index = 0						ASTM E84
<b>Chemical behaviour</b>	-	-	AS-Quality Do not contribute to corrosion of stainless steel Produced without addition of silicone No short term water absorption by partial immersion (WS1)						AGI Q 132 EN 13468 ASTM C795 EN 1609
<b>Application field</b>	-	-	Product for use in technical applications, such as inaccessible cavities, complicated confined surfaces or dead spaces Certified for use in nuclear applications (PMUC 09-0001)						EN 14303 PMUC 09-0001
<b>Material</b>	-	-	Loose stone mineral wool without binder With quality marks EUCEB, unrisky regarding health according to regulation EC No 1272/2008 Note Q						CINI 2.2.04
<b>Quality management</b>	-	-	CE-marked according to EN 14303 ISOVER is certified according to EN ISO 9001 and EN ISO 14001						EN 14303 EN ISO 9001 EN ISO 14001
<b>Miscellaneous</b>	-	-	Storage: Bags to be stored indoors in a dry and clean place away from source of humidity						EN 14303
<b>Delivery form</b>	-	-	Please contact your local ISOVER dealer All dimensions require minimum order quantities						-

\* Indicative values for a homogeneous density of around 100 kg/m<sup>3</sup>. Values may vary according to density and stuffing quality.



# TECH Loose Wool QN

## Nuclear-quality-designed special loose white glass mineral wool roll

TECH Loose Wool QN is a non-bonded, resilient white glass mineral wool roll with almost no organic content specially designed to meet the strict requirements of the nuclear industry for insulation inside the nuclear island. It can be used for insulation of dead spaces, joints or as a basis filling for industrial mattresses. The resilience of the special glass mineral wool roll fibers will guaranty a long-lasting sustainable performance. The product is designed to be applied on walls of vessels containing cryogenic liquids, as well as allows to insulate inaccessible cavities and confined spaces.



### Nuclear plant quality

Especially designed and certified for use in nuclear applications



### High flexibility

Flexible to use non-bonded glass wool for filling of jonts and dead spaces



### Lightweight

Lightweight solution with up to 50 % weight savings compared to standard insulation solutions



### Fire reaction

Non-combustible, Euroclass A1 for effective fire protection on industry sites



### Improved logistics

Transport and storage savings with up to 80 % more material per pallet than standard solutions



ISOVER-TDS-Industry-INT-ENG-TECH Loose Wool QN 2019-09





## Nuclear-quality-designed special loose white glass mineral wool roll

Characteristic	Symbol	Unit	Quantities and declared values									Standard
<b>Thermal behaviour</b>	T	[°C]	Operating temperature range -200 °C until +400 °C									EN 14706
<b>Thermal conductivity*</b>	T	[°C]	-120	-80	-30	0	50	100	150	200	300	EN 12667 ISO 13787
		[W/(m•K)]	0.017	0.022	0.027	0.031	0.038	0.045	0.052	0.062	0.083	
<b>Fire protection / Behaviour in fire</b>	-	-	Non combustible; Euroclass A1									EN 13501-1
			Fire Spread Index = 0; Smoke Development Index < 20									ASTM E84
<b>Chemical behaviour</b>	-	-	AS-Quality Do not contribute to corrosion of stainless steel Do not contain silicone									AGI Q 132 ASTM C795
<b>Application field</b>	-	-	Designe Product for use in technical applications, such as inaccessible cavities, complicated confined surfaces or dead spaces Especially designed and certified for use in nuclear applications (PMUC 09-0054)									EN 14303 PMUC 09-0054
<b>Material</b>	-	-	Loose glass mineral wool roll without binder With quality marks EUCEB and RAL by the Gütegemeinschaft Mineralwolle e. V., unrisky regarding health according to German decree on dangerous substances, decree on prohibition of chemicals and to regulation EC No 1272/2008 Note Q									CINI 2.1.04
<b>Quality management</b>	-	-	CE-marked according to EN 14303 ISOVER is certified according to EN ISO 9001 and EN ISO 14001									EN 14303 EN ISO 9001 EN ISO 14001
<b>Miscellaneous</b>	-	-	Storage: Bags to be stored indoors in a dry and clean place away from source of humidity									EN 14303
<b>Delivery form</b>	-	-	Packaging: Loose wool in bags of 8 kg Please contact your local ISOVER dealer All dimensions require minimum order quantities									-

\* Indicative values for a homogeneous density of around 60 kg/m<sup>3</sup>. Values may vary according to density and stuffing quality.



# TECH Pipe Section MT 4.0

## Preformed, concentric-rolled glass mineral wool pipe sections

TECH Pipe Section MT 4.0 is the preformed concentric-rolled glass mineral wool pipe section for the insulation of industry process pipelines for diameters from 12.7 mm to 254 mm (1/2" to 10"), exhaust ducts and stacks. Pre-slit to facilitate the opening and fitting over the pipes, TECH Pipe Section MT 4.0 are light and easy to handle. With a length of 1.2 m, installation time on straight pipes and thermal bridges through joints can be reduced by 20 %. TECH Pipe Section MT 4.0 can be used for service temperatures up to 400 °C.



### Thermal insulation

Standard-Plus thermal insulation performance for service temperatures up to 400 °C



### Easy handling

Especially packacked in bags for easy handling



### Cost effective solution

Standard-Plus thermal performance combined with lightweight provides installation time saving and less heat loss costs



### Fire reaction

Non-combustible, Euroclass A1 for effective fire protection on industry sites



### Fast installation

Up to 20 % faster to install than standard stone wool pipe insulation due to lightweight, 1.2 m length and easy handling



### Lightweight

Lightweight solution with up to 50 % weight savings compared to standard insulation solutions



### Thermal Efficiency Indicator

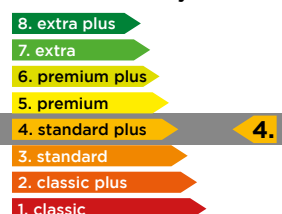



## Preformed, concentric-rolled glass mineral wool pipe sections

Characteristic	Symbol	Unit	Quantities and declared values	Standard					
<b>Thermal behaviour Max. service temp.</b>	T	[°C]	400 (under 500 Pa)	EN 14707					
<b>Thermal conductivity</b>	T	[°C]	50	100	150	200	250	300	ISO 8497 ISO 13787
		[W/(m•K)]	0.037	0.046	0.056	0.068	0.082	0.098	
<b>Specific thermal capacity</b>	c	[kJ/(kg•K)]	1.03						ISO 10456
<b>Fire protection / Behaviour in fire</b>	-	-	Non combustible; Euroclass A1 <sub>L</sub>						EN 13501-1
			Fire Spread Index = 0; Smoke Development Index < 20						ASTM E84
<b>Chemical behaviour</b>	-	-	AS-Quality Do not contribute to corrosion of stainless steel No short term water absorption by partial immersion (WS1)						AGI Q 132 ASTM C795 EN 1609
<b>Application field</b>	-	-	Product for use in technical applications, such as small diameter pipes, exhaust ducts and stacks, with need for: thermal and/or acoustic insulation performances especially at medium temperatures						EN 14303
<b>Material</b>	-	-	Glass mineral wool, preformed concentric-rolled in shape of pipe section With quality marks EUCEB, unriskey regarding health according to regulation EC No 1272/2008 Note Q						CINI 2.1.03
<b>Facing</b>	-	-	-						-
<b>Quality management</b>	-	-	CE-marked according to EN 14303 ISOVER is certified according to EN ISO 9001 and EN ISO 14001						EN 14303 EN ISO 9001 EN ISO 14001
<b>Miscellaneous</b>	-	-	MW-EN 14303-T8/T9-ST(+)400-WS1						EN 14303

Delivery form: Standard dimensions / packaging information*												
Thickness d [mm]	Diameter ø [mm]											
	21	27	34	42	48	60	76	89	114	140	169	219
	Linear meter / pack											
30	44.4	38.4	32.4	27.6	25.2	21.6	15.6	13.2	9.6	7.2	6.0	3.6
40	30.0	26.4	22.8	20.4	18.0	15.6	12.0	10.8	8.4	6.0	4.8	3.6
50			16.8	14.4	13.2	12.0	9.6	8.4	7.2	4.8	4.8	3.6
60									6.0	4.8	3.6	2.4

\* all dimensions require minimum order quantities / other dimensions on request



# TECH Pipe Section MT 4.1

## Preformed, concentric-rolled stone mineral wool pipe sections

TECH Pipe Section MT 4.1 is the preformed concentric-rolled stone mineral wool pipe section for the insulation of industry process pipelines for diameters from 21 mm to 273 mm (1/2" to 10"), exhaust ducts and stacks. Pre-slit to facilitate the opening and fitting over the pipes, TECH Pipe Section MT 4.1 are easy to handle. With a length of 1.2 m, installation time on straight pipes and thermal bridges can be reduced by 20 %. TECH Pipe Section MT 4.1 can be used for service temperatures up to 650 °C.



### Thermal insulation

Standard-Plus thermal insulation performance for service temperatures up to 650 °C



### Easy handling

Especially packacked in bags for easy handling



### High service temperatures

Especially designed for high service temperatures up to 650 °C



### Cost effective solution

Standard-Plus thermal performance combined with lightweight provides installation time saving and less heat loss costs



### Fire reaction

Non-combustible, Euroclass A1 for effective fire protection on industry sites



### Mechanical resistance

High compressive strength for installation without support structures



### Thermal Efficiency Indicator

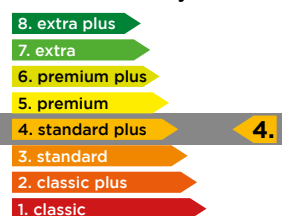



## Preformed, concentric-rolled stone mineral wool pipe sections

Characteristic	Symbol	Unit	Quantities and declared values						Standard
Thermal behaviour Max. service temp.	T	[°C]	650 (under 500 Pa)						EN 14707
			700						ASTM C411
Thermal conductivity	T	[°C]	50	100	150	200	250	300	ISO 8497
		[W/(m•K)]	0.038	0.045	0.054	0.063	0.073	0.084	ISO 13787
Specific thermal capacity	c	[kJ/(kg•K)]	1.03						ISO 10456
Fire protection / Behaviour in fire	-	-	Non combustible; Euroclass A1 <sub>l</sub>						EN 13501-1
			Fire Spread Index = 0; Smoke Development Index < 20						ASTM E84
Chemical behaviour	-	-	AS-Quality Do not contribute to corrosion of stainless steel No short term water absorption by partial immersion (WS1) Water Vapor Sorption less than 1.45 %						AGI Q 132 ASTM C795 EN 1609 ASTM C1104
Application field	-	-	Product for use in technical applications, such as small diameter pipes, exhaust ducts and stacks, with need for thermal and/or acoustic insulation performances especially at high temperatures						EN 14303
Material	-	-	Stone mineral wool, preformed concentric-rolled in shape of pipe section With quality marks EUCEB, unrisky regarding health according to regulation EC No1272/2008 Note Q						CINI 2.2.03
Facing	-	-	-						-
Quality management	-	-	CE-marked according to EN 14303 ISOVER is certified according to EN ISO 9001 and EN ISO 14001						EN 14303 EN ISO 9001 EN ISO 14001
Miscellaneous	-	-	MW-EN 14303-T8/T9-ST(+)-650-WS1						EN 14303

Delivery form: Standard dimensions / packaging information*													
Thickness d [mm]	Diameter ø [mm]												
	21	27	34	42	48	60	76	89	114	140	169	219	273
	Linear meter / pack												
30	42.0	38.4	30.0	27.6	22.8	20.4	14.4	12.0	8.4		4.8		
40	27.6	25.2	21.6	20.4	16.8	14.4	10.8	9.6	7.2		3.6	2.4	2.4
50		18.0	15.6	14.4	12.0	10.8	8.4	7.2	6.0	4.8	3.6	2.4	1.2
60			12.0		9.6	8.4	6.0	6.0	4.8	3.6	2.4	2.4	1.2
80						4.8	4.8	3.6	3.6		2.4	1.2	1.2

\* all dimensions require minimum order quantities / other dimensions on request



# TECH Pipe Section MT 4.2

## Preformed, concentric-rolled glass mineral wool pipe sections

TECH Pipe Section MT 4.2 is the preformed concentric-rolled glass mineral wool pipe section for the insulation of industry process pipelines for diameters from 12.7 mm to 254 mm (1/2" to 10"), exhaust ducts and stacks. Pre-slit to facilitate the opening and fitting over the pipes, TECH Pipe Section MT 4.2 are light and easy to handle. With a length of 1.2 m, installation time on straight pipes and thermal bridges can be reduced by 20 %. TECH Pipe Section MT 4.2 can be used for service temperatures up to 500 °C.



### Thermal insulation

Standard-Plus thermal insulation performance for service temperatures up to 500 °C



### Fast installation

Up to 20 % faster to install than standard stone wool pipe insulation due to lightweight, 1.2 m length and easy handling



### Cost effective solution

Standard-Plus thermal performance combined with lightweight provides installation time saving and less heat loss costs



### Lightweight

Lightweight solution with up to 50 % weight savings compared to standard insulation solutions



### Thermal Efficiency Indicator

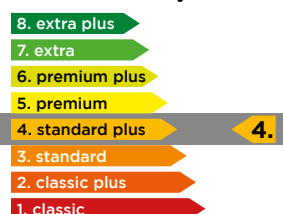

# TECH Pipe Section MT 4.2



## Preformed, concentric-rolled glass mineral wool pipe sections

Characteristic	Symbol	Unit	Quantities and declared values							Standard
<b>Thermal behaviour</b> Max. service temp.	T	[°C]	500 (under 500 Pa)							EN 14707
<b>Thermal conductivity</b>	T	[°C]	10	50	100	200	300	400	500	ISO 8497 ISO 13787
		[W/(m•K)]	0.033	0.036	0.043	0.062	0.092	0.130	0.179	
<b>Specific thermal capacity</b>	c	[kJ/(kg•K)]	1.03							ISO 10456
<b>Fire protection / Behaviour in fire</b>	-	-	Euroclass A <sub>2</sub> -s <sub>1</sub> , d <sub>0</sub>							EN 13501-1
<b>Chemical behaviour</b>	-	-	AS-Quality Do not contribute to corrosion of stainless steel							AGI Q 132 ASTM C795
<b>Application field</b>	-	-	Product for use in technical applications, such as small diameter pipes, exhaust ducts and stacks, with need for: thermal and/or acoustic insulation performances especially at medium temperatures							EN 14303
<b>Material</b>	-	-	Glass mineral wool, preformed concentric-rolled in shape of pipe section With quality marks EUCEB, unrisky regarding health according to regulation EC No 1272/2008 Note Q							CINI 2.1.03
<b>Facing</b>	-	-	-							-
<b>Quality management</b>	-	-	CE-marked according to EN 14303 ISOVER is certified according to EN ISO 9001 and EN ISO 14001							EN 14303 EN ISO 9001 EN ISO 14001
<b>Miscellaneous</b>	-	-	MW-EN 14303-T8/T9-ST(+)-500							EN 14303

Delivery form: Standard dimensions / packaging information*																								
Thickness d [mm]	Diameter ø [mm]																				Linear meter / pack			
	15	18	22	28	35	42	48	54	60	64	70	76	83	89	102	108	114	133	140	159	168	194	219	273
	20	42.0	36.0	33.6	36.0	30.0	24.0	21.6	19.2	15.6	24.0	12.0	18.0	10.8	10.8									
30	30.0	30.0	24.0	21.6	19.2	15.6	14.4	12.0	10.8	10.8	10.8	14.4	7.2	9.6	4.8	4.8	4.8	4.8	4.8	3.6	3.6	3.6	2.4	1.2
40	19.2	19.2	15.6	14.4	12.0	10.8	10.8	8.4	7.2	7.2	9.6	9.6	4.8	4.8	4.8	4.8	4.8	4.8	3.6	3.6	3.6	2.4	2.4	1.2
50	12.0	10.8	10.8	10.8	8.4	7.2	9.6	9.6	6.0	4.8	4.8	4.8	4.8	4.8	4.8	4.8	4.8	3.6	3.6	3.6	2.4	2.4	1.2	1.2
60	8.4	7.2	7.2	9.6	9.6	4.8	4.8	4.8	4.8	4.8	4.8	4.8	4.8	4.8	3.6	3.6	3.6	3.6	3.6	2.4	2.4	1.2	1.2	1.2
80				4.8	4.8	4.8	4.8	4.8	3.6	3.6	3.6	3.6	3.6	3.6	2.4	2.4	2.4	2.4	2.4	1.2	1.2	1.2	1.2	1.2
100						3.6	3.6	3.6	3.6	2.4	2.4	2.4	2.4	2.4	1.2	1.2	1.2	1.2	1.2	1.2	1.2	1.2	1.2	1.2
120								2.4	2.4	1.2	1.2	1.2	1.2	1.2	1.2	1.2	1.2	1.2	1.2	1.2	1.2	1.2	1.2	1.2

\* all dimensions require minimum order quantities / other dimensions on request



# U TECH Pipe Section MT 4.0

## The **ULTIMATE** solution for industry pipe insulation

ULTIMATE U TECH Pipe Section MT 4.0 is the efficient and light alternative for the insulation of industry process pipelines for standard pipe diameters from 15 mm to 356 mm (1/2" to 14"). The ULTIMATE mineral wool preformed concentric-rolled pipe section is equipped with a pre-slit to facilitate the opening and fitting over the pipes. U TECH Pipe Section MT 4.0 are light and easy to handle. With a length of 1.2 m, installation time on straight pipes and thermal bridges through joints can be reduced by 20 %. U TECH Pipe Section MT 4.0 can be used for service temperatures of up to 660 °C.



### High service temperatures

Especially designed for high service temperatures up to 660 °C



### Cost effective solution

Standard-Plus thermal performance combined with lightweight provides installation time saving and less heat loss costs



### Thermal insulation

Standard-Plus thermal performance for service temperatures up to 660° C with up to 35 % better efficiency than standard solutions



### Fast installation

By cut-to-fit dimension, it reduces weight per piece and can be handled by one person only. No need of spacers or similar.



### Nuclear plant quality

Certified for use in nuclear applications



### Fire reaction

Non-combustible, Euroclass A1 for effective fire protection on industry sites



### Thermal Efficiency Indicator

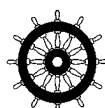
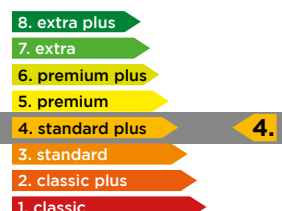



## The ULTIMATE solution for industry pipe insulation

Characteristic	Symbol	Unit	Quantities and declared values							Standard
Thermal behaviour Max. service temp.	T	[°C]	660 (under 500 Pa)							EN 14707
			700							ASTM C411
Thermal conductivity	T	[°C]	40	50	100	150	200	300	ISO 8497	
		[W/(m•K)]	0.035	0.037	0.043	0.052	0.062	0.089	ISO 13787	
Specific thermal capacity	c	[kJ/(kg•K)]	1.03							ISO 10456
Fire protection / Behaviour in fire	-	-	Non combustible; Euroclass A1 <sub>l</sub>							EN 13501-1
			Fire Spread Index = 0; Smoke Development Index < 20							ASTM E84
			IMO-Resolution MSC.61(67); IMO MSC/Circ. 1120							FTP Code
Chemical behaviour	-	-	AS-Quality							AGI Q 132
			Leachable chloride content less than 10 ppm (CL10)							EN 13468
			Do not contribute to corrosion of stainless steel							ASTM C795
			No short term water absorption by partial immersion (WS1)							EN 1609
Application field	-	-	Product for use in technical applications, such as big diameter pipes, exhaust ducts and stacks, with need for: thermal and/or acoustic insulation with high performances especially at high temperatures Certified for use in nuclear applications (PMUC 09-0075)							EN 14303 PMUC 09-0075 DIN 4140
Material	-	-	ULTIMATE mineral wool, preformed concentric in shape of pipe section With quality marks EUCEB and RAL by the Gütegemeinschaft Mineralwolle e. V., unriskey regarding health according to German decree on dangerous substances, decree on prohibition of chemicals and to regulation EC No1272/2008 Note Q							CINI 2.1.03
Facing	-	-	-							-
Quality management	-	-	CE-marked according to EN 14303. Quality control according to VDI 2055 ISOVER is certified according to EN ISO 9001 and EN ISO 14001							EN 14303 VDI 2055 EN ISO 9001 EN ISO 14001
Miscellaneous	-	-	Insulating material identification number: 10.04.03.99.99 MW-EN14303-T8-ST(+)-660-WS1-CL10 (outside pipe ø ≤ 150 mm) MW-EN14303-T9-ST(+)-660-WS1-CL10 (outside pipe ø > 150 mm)							AGI Q 132 EN 14303

Delivery form: Standard dimensions / packaging information*																							
Thickness d [mm]	Diameter ø [mm]																						
	15	18	22	28	35	42	48	54	57	60	64	70	76	89	102	108	114	133	140	159	168	219	273
	Linear meter / pack																						
20	57.6	50.4	43.2	36.0	30.0	24.0	19.2	28.8	28.8	27.6	24.0			16.8									
30	30.0	28.8	24.0	19.2	19.2	14.4	24.0	19.2	19.2	19.2	18.0	14.4	14.4	10.8	9.6	9.6	7.2	6.0	6.0	4.8	4.8	1.2	1.2
40		28.8	14.4	19.2	10.8	10.8	9.6	10.8	10.8	10.8	10.8	10.8	10.8	9.6	7.2	7.2	6.0	4.8	4.8	4.8	3.6	1.2	1.2
50			18.0	14.4	10.8	10.8	10.8	10.8	10.8	9.6	9.6	9.6	4.8	4.8	6.0	6.0	4.8	4.8	3.6	3.6	1.2	1.2	1.2
60			10.8	10.8	10.8	9.6	9.6	4.8	4.8	4.8	4.8	4.8	6.0	4.8	4.8	4.8	4.8	3.6	1.2	1.2	1.2	1.2	1.2
70										4.8	4.8	4.8	4.8	4.8	3.6	3.6	3.6	1.2	1.2	1.2	1.2	1.2	1.2
80						6.0	4.8						4.8	4.8	3.6	1.2	1.2	1.2	1.2	1.2	1.2	1.2	1.2
90															1.2								
100													1.2	1.2	1.2	1.2	1.2	1.2	1.2	1.2	1.2	1.2	1.2
120																					1.2	1.2	1.2

\* all dimensions require minimum order quantities / other dimensions on request



# U TECH Pipe Section Mat MT 7.0 G1

## The **ULTIMATE** solution for efficient large-diameter industry pipe insulation

ULTIMATE U TECH Pipe Section Mat (PSM) MT 7.0 G1 is the extra-efficient and fast solution to insulate large-diameter industry process pipelines with external diameters greater or equal than 324 mm (12") with a maximum service temperature of 620 °C. The length and the V-shaped cuts of the PSM are adapted to the final diameter and thickness of the pipe insulation, leaving no thermal bridges once installed. A glass woven fabric facing improves the mechanical resistance during and after installation. The product is delivered space-saving flat on pallets, but can be ordered like a pipe section indicating diameter, thickness and linear meter of pipe insulation. Pre-cutted parts to form elbows and connections are available on request. U TECH PSM MT 7.0 G1 is produced in AS-Quality (CL- ≤10 ppm) for usage in contact with austenitic steel pipes. On request with black glass fabric (G1).



### Energy efficiency

Extra thermal performance for service temperatures up to 620 °C with up to 35 % better efficiency



### High service temperatures

Especially designed for high service temperatures up to 620 °C



### Cost effective solution

Extra thermal performance combined with lightweight provides installation time saving and less heat loss costs



### Thin solution

Personal protection and heat loss requirements achieved with up to 35 % less insulation thickness than standard solutions



### Fire reaction

Non-combustible, Euroclass A1 for effective fire protection on industry sites



### Thermal Efficiency Indicator

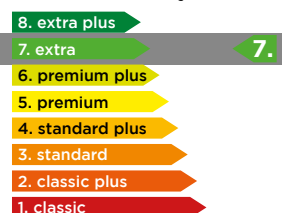



## The ULTIMATE solution for efficient large-diameter industry pipe insulation

Characteristic	Symbol	Unit	Quantities and declared values	Standard		
<b>Thermal behaviour Max. service temp.</b>	T	[°C]	620 (under 500 Pa)	EN 14707		
			700	ASTM C411		
<b>Thermal conductivity</b>	T	[°C]		50 100 150 200 300 400 500 600		
			[W/(m•K)]	ø ≥ 500 mm	0.035 0.040 0.046 0.054 0.070 0.091 0.116 0.146	ISO 8497
				ø < 500 mm	0.038 0.045 0.054 0.065 0.092 - - -	EN 12667
<b>Specific thermal capacity</b>	c	[kJ/(kg•K)]	1.03	ISO 10456		
<b>Fire protection / Behaviour in fire</b>	-	-	Non combustible; Euroclass A1 <sub>L</sub>	EN 13501-1		
<b>Chemical behaviour</b>	-	-	AS-Quality Leachable chloride content less than 10 ppm (CL10) Do not contribute to corrosion of stainless steel No short term water absorption by partial immersion (WS1)	AGI Q 132 EN 13468 ASTM C795 EN 1609		
<b>Application field</b>	-	-	Product for use in technical applications, such as big diameter pipes	EN 14303		
<b>Material</b>	-	-	ULTIMATE mineral wool, faced with a black glass woven fabric With quality marks EUCEB and RAL by the Gütegemeinschaft Mineralwolle e. V., unrisky regarding health according to German decree on dangerous substances, decree on prohibition of chemicals and to regulation EC No 1272/2008 Note Q	CINI 2.1.03		
<b>Facing</b>	-	-	On request: Black glass fabric facing (G1)	-		
<b>Quality management</b>	-	-	CE-marked according to EN 14303 ISOVER is certified according to EN ISO 9001 and EN ISO 14001	EN 14303 EN ISO 9001 EN ISO 14001		
<b>Miscellaneous</b>	-	-	Insulating material identification number: 10.04.03.99.08 MW-EN 14303-T9-ST(+)-620-WS1-CL10	AGI Q 132 EN 14303		

### Delivery form: Standard dimensions / packaging information\*

Thickness d [mm]	Diameter ø [mm]													
	324	356	368	406	419	457	508	610	660	712	762	813	914	1016
	Number of U TECH Pipe Section Mat per pallet / total length of insulated pipe [m]													
50	-	22/13.75	22/13.75	22/13.75	22/13.75	22/13.75	22/13.75	22/13.75	22/13.75	22/13.75	22/13.75	22/13.75	22/13.75	22/13.75
60	-	18/11.25	18/11.25	18/11.25	18/11.25	18/11.25	18/11.25	18/11.25	18/11.25	18/11.25	18/11.25	18/11.25	18/11.25	18/11.25
80	14/8.75	14/8.75	14/8.75	14/8.75	14/8.75	14/8.75	14/8.75	14/8.75	14/8.75	14/8.75	14/8.75	14/8.75	14/8.75	14/8.75
100	10/6.25	10/6.25	10/6.25	10/6.25	10/6.25	10/6.25	10/6.25	10/6.25	10/6.25	10/6.25	10/6.25	10/6.25	10/6.25	10/6.25

Wooden pallet sizes: 1,200 x 1,200 mm or 2,000 x 1,200 mm.

\* all dimensions require minimum order quantities / other dimensions on request



# CRYOLENE 681 AA & VV

## Resilient glass mineral wool blankets engineered for cryogenic tank decks

Design specifications for storage tanks containing cryogenic fluids such as liquefied natural gas (LNG), ethylene or nitrogen for chemical or combustion processes, are not only highly demanding in terms of construction, but also in terms of insulation. With the tank volume expanding and contracting depending on the level of liquid inside, the insulation must offer high levels of both compressibility and resilience. To meet this requirement, ISOVER has developed the unique CRYOLENE product range.

CRYOLENE 681 has been designed for the insulation of cryogenic tank suspended decks. The properties and performance of CRYOLENE 681 have been extensively tested by external institutes and the products are well-proven through decades of successful use worldwide in chemical and LNG applications.



### Lightweight

Lightweight solution with up to 50 % weight savings compared to standard insulation solutions



### Fast installation

Flexibility, lightweight and long-length rolls helps to handle and install CRYOLENE 681 easier and faster



### Thermal Insulation

Excellent thermal insulation performance at cryogenic temperatures



### Fire reaction

Non-combustible, Euroclass A1 for effective fire protection on industry sites



### Improved logistics

Transport and storage savings with up to 80 % more material per pallet than standard solutions



# CRYOLENE 681 AA & VV



## Resilient glass mineral wool blankets engineered for cryogenic tank decks

Characteristic	Symbol	Unit	Quantities and declared values						Standard
<b>Thermal behaviour</b>	T	[°C]	Operating temperature range -170 °C until + 120 °C						-
<b>Thermal conductivity</b>	T	[°C]	-150	-120	-100	-50	0	10	EN 12667 ISO 13787
		[W/(m•K)]	0.015	0.019	0.021	0.028	0.037	0.039	
<b>Specific thermal capacity</b>	c	[kJ/(kg•K)]	1.03						ISO 10456
<b>Fire protection / Behaviour in fire</b>	-	-	681 VV: Non combustible; Euroclass A1 681 AA: Euroclass A2-s1, d0						EN 13501-1
			681 VV: Fire Spread Index = 0; Smoke Development Index < 20 681 AA: Fire Spread Index < 25; Smoke Development Index < 25						ASTM E84
<b>Tensile strength</b>	-	-	681 VV: reinforced glass veil 681 AA: reinforced aluminium foil The facing contributes to provide the CRYOLENE blanket its tensile strength						-
<b>Chemical behaviour</b>	-	-	Do not contribute to corrosion of stainless steel No short term water absorption by partial immersion (WS1)						ASTM C795 EN 1609
<b>Application field</b>	-	-	Product for use in cryogenic applications, such as Liquid Natural Gas storage tanks Shall be enclosed in vapor and water tight construction Non compatible with liquid oxygen						EN 14303
<b>Material</b>	-	-	CRYOLENE products are highly resilient glass mineral wool rolls designed to retain their fibers elasticity over time at temperatures ranging from -170 °C to +120 °C With quality marks EUCEB and RAL by the Gütegemeinschaft Mineralwolle e. V., unriskey regarding health according to German decree on dangerous substances, decree on prohibition of chemicals and to regulation EC No 1272/2008 Note Q						CINI 2.1.02
<b>Facing</b>	-	-	681 VV: faced with a yellow glass veil 681 AA: faced on one side with reinforced aluminium						-
<b>Quality management</b>	-	-	CE-marked according to EN 14303 ISOVER is certified according to EN ISO 9001 and EN ISO 14001						EN 14303 EN ISO 9001 EN ISO 14001
<b>Miscellaneous</b>	-	-	Storage: Rolls must be stocked vertically For best resilient characteristics, all CRYOLENE references should not be stocked more than 3 months MW-EN 14303-T1-WS1						EN 14303
<b>Delivery form</b>	-	-	Please contact your local ISOVER dealer All dimensions require minimum order quantities						-



# CRYOLENE 682 AA & VV

## Resilient glass mineral wool blankets engineered for cryogenic tank walls

Design specifications for storage tanks containing cryogenic fluids such as liquefied natural gas (LNG), ethylene or nitrogen for chemical or combustion processes, are not only highly demanding in terms of construction, but also in terms of insulation. With the tank volume expanding and contracting depending on the level of liquid inside, the insulation must offer high levels of both compressibility and resilience. To meet this requirement, ISOVER has developed the unique CRYOLENE product range.

CRYOLENE 682 has been designed for the insulation of cryogenic tank walls. The properties and performance of CRYOLENE 682 have been extensively tested by external institutes and the products are well-proven through decades of successful use worldwide in chemical and LNG applications.



### High flexibility

High resilience and flexibility designed to meet the mechanical demands of cryogenic tanks during its full operational lifetime



### Improved logistics

Transport and storage savings with up to 80 % more material per pallet than standard solutions



### Fast installation

Flexibility, lightweight and long-length with high tensile-strength facing helps to handle and install CRYOLENE 682 rolls easier and faster



### Thermal insulation

Excellent thermal insulation performance at cryogenic temperatures



### Lightweight

Lightweight solution with up to 50 % weight savings compared to standard insulation solutions



ISOVER-TDS-Industry-INT-ENG-CRYOLENE 682 AA & VV 2019-09





## Resilient glass mineral wool blankets engineered for cryogenic tank walls

Characteristic	Symbol	Unit	Quantities and declared values						Standard
<b>Thermal behaviour</b>	T	[°C]	Operating temperature range -170 °C until + 120 °C						-
<b>Thermal conductivity</b>	T	[°C]	-150	-120	-100	-50	0	10	EN 12667 ISO 13787
		[W/(m•K)]	0.013	0.017	0.019	0.026	0.034	0.036	
<b>Specific thermal capacity</b>	c	[kJ/(kg•K)]	1.03						ISO 10456
<b>Fire protection / Behaviour in fire</b>	-	-	Non combustible; Euroclass A2-s1, d0						EN 13501-1
			Fire Spread Index < 25; Smoke Development Index < 25						ASTM E84
<b>Tensile strength</b>	-	-	682 VV: reinforced glass veil 682 AA: reinforced aluminium foil The facing contributes to provide the CRYOLENE blanket its tensile strength						-
<b>Resilience</b>	-	[kN/m <sup>2</sup> ]	SNCMP method	0.5	1.0	2.5	4.0	-	
		[%/Load]		65	50	35	29		
<b>Chemical behaviour</b>	-	-	Do not contribute to corrosion of stainless steel No short term water absorption by partial immersion (WS1)						ASTM C795 EN 1609
<b>Application field</b>	-	-	Product for use in cryogenic applications, such as Liquid Natural Gas storage tanks Shall be enclosed in vapor and water tight construction Non compatible with liquid oxygen						EN 14303
<b>Material</b>	-	-	CRYOLENE products are highly resilient glass mineral wool rolls designed to retain their fibers elasticity over time at temperatures ranging from -170 °C to +120 °C With quality marks EUCEB and RAL by the Gütegemeinschaft Mineralwolle e. V., unrisky regarding health according to German decree on dangerous substances, decree on prohibition of chemicals and to regulation EC No 1272/2008 Note Q						CINI 2.1.02
<b>Facing</b>	-	-	682 VV: faced with a yellow glass veil 682 AA: faced on one side with reinforced aluminum						-
<b>Quality management</b>	-	-	CE-marked according to EN 14303 ISOVER is certified according to EN ISO 9001 and EN ISO 14001						EN 14303 EN ISO 9001 EN ISO 14001
<b>Miscellaneous</b>	-	-	Storage: Rolls must be stocked vertically For best resilient characteristics, all CRYOLENE references should not be stocked more than 3 months MW-EN 14303-T3-WS1						EN 14303
<b>Delivery form</b>	-	-	Please contact your local ISOVER dealer All dimensions require minimum order quantities						-



# CRYOLENE 684 AA & VV

## Resilient glass mineral wool blankets engineered for cryogenic applications

Design specifications for storage tanks containing cryogenic fluids such as liquefied natural gas (LNG), ethylene or nitrogen for chemical or combustion processes, are not only highly demanding in terms of construction, but also in terms of insulation. With the tank volume expanding and contracting depending on the level of liquid inside, the insulation must offer high levels of both compressibility and resilience. To meet this requirement, ISOVER has developed the unique CRYOLENE product range.

CRYOLENE 684 has been designed for the insulation of cryogenic pipe expansions. The properties and performance of CRYOLENE 684 have been extensively tested by external institutes and the products are well-proven through decades of successful use worldwide in chemical and LNG applications.



### Thermal insulation

Excellent thermal insulation performance at cryogenic temperatures



### Fast installation

Flexibility, lightweight and long-length rolls helps to handle and install CRYOLENE 684 easier and faster



### Fire reaction

Non-combustible, Euroclass A1 for effective fire protection on industry sites



### Sound absorption

Up to 95 % of sound energy absorbed due to optimal longitudinal air flow resistance and uniform porosity values



### High flexibility

High resilience and flexibility designed to meet the mechanical demands of cryogenic tanks during its full operational lifetime





## Resilient glass mineral wool blankets engineered for cryogenic applications

Characteristic	Symbol	Unit	Quantities and declared values	Standard
<b>Thermal behaviour</b>	T	[°C]	Operating temperature range -170 °C until + 120 °C	-
<b>Thermal conductivity</b>	T	[°C]	-150   -120   -100   -50   0   10	EN 12667 ISO 13787
		[W/(m•K)]	0.013   0.017   0.019   0.026   0.034   0.036	
<b>Specific thermal capacity</b>	c	[kJ/(kg•K)]	1.03	ISO 10456
<b>Fire protection / Behaviour in fire</b>	-	-	684 VV: Non combustible; Euroclass A1 684 AA: Euroclass A2-s1, d0	EN 13501-1
			684 VV: Fire Spread Index = 0; Smoke Development Index < 20 684 AA: Fire Spread Index < 25; Smoke Development Index < 25	ASTM E84
<b>Tensile strength</b>	-	-	684 VV: reinforced glass veil 684 AA: reinforced aluminium foil The facing contributes to provide the CRYOLENE blanket its tensile strength	-
<b>Chemical behaviour</b>	-	-	Do not contribute to corrosion of stainless steel No short term water absorption by partial immersion (WS1)	ASTM C795 EN 1609
<b>Application field</b>	-	-	Product for use in cryogenic applications, such as Liquid Natural Gas storage tanks Shall be enclosed in vapor and water tight construction Non compatible with liquid oxygen	EN 14303
<b>Material</b>	-	-	CRYOLENE products are highly resilient glass mineral wool rolls designed to retain their fibers elasticity over time at temperatures ranging from -170 °C to +120 °C With quality marks EUCEB and RAL by the Gütegemeinschaft Mineralwolle e. V., unriskey regarding health according to German decree on dangerous substances, decree on prohibition of chemicals and to regulation EC No 1272/2008 Note Q	CINI 2.1.02
<b>Facing</b>	-	-	684 VV: faced with a yellow glass veil 684 AA: faced on one side with reinforced aluminum	-
<b>Quality management</b>	-	-	CE-marked according to EN 14303 ISOVER is certified according to EN ISO 9001 and EN ISO 14001	EN 14303 EN ISO 9001 EN ISO 14001
<b>Miscellaneous</b>	-	-	Storage: Rolls must be stocked vertically For best resilient characteristics, all CRYOLENE references should not be stocked more than 3 months MW-EN 14303-T2-WS1	EN 14303
<b>Delivery form</b>	-	-	Please contact your local ISOVER dealer All dimensions require minimum order quantities	-



# TECH Crimped Roll 1.0 Alu1

## Ultra light and flexible industry glass mineral wool roll with crimped fiber structure

TECH Crimped Roll 1.0 is a flexible and ultra-light weight glass mineral wool roll solution for thermal and acoustic insulation of various industry insulation equipment such as big diameter pipes, tanks and vessels. Due to the crimped fiber structure the compressive strength is improved while maintaining a classic thermal performance. TECH Crimped Roll 1.0 can be used for service temperatures up to 350 °C. On request with reinforced aluminium facing (Alu1).



### Fast installation

Flexibility, lightweight and compressibility helps to handle and install the product easier and faster



### Mechanical resistance

Improved compressive-strength for better mechanical behaviour and lower weight through crimped, non-linear fiber structure



### Thermal insulation

Classic thermal insulation performance for service temperatures up to 350 °C



### Fire reaction

Non-combustible, Euroclass A1 for effective fire protection on industry sites



### Lightweight

Lightweight solution with up to 50 % weight savings compared to standard insulation solutions



### Improved logistics

Transport and storage savings with up to 80 % more material per pallet than standard solutions



### Thermal Efficiency Indicator

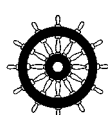
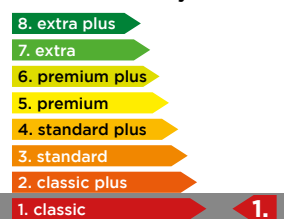

# TECH Crimped Roll 1.0 Alu1



## Ultra light and flexible industry glass mineral wool roll with crimped fiber structure

Characteristic	Symbol	Unit	Quantities and declared values	Standard
<b>Thermal behaviour</b>	T	[°C]	350 (under 250 Pa)	EN 14706
<b>Thermal conductivity</b>	T	[°C]	50    100    150    200    250    300	EN 12667 ISO 13787
		[W/(m•K)]	0.044    0.056    0.072    0.095    0.120    0.150	
<b>Fire protection / Behaviour in fire</b>	-	-	Non combustible; Euroclass A1	EN 13501-1
			Fire Spread Index = 0; Smoke Development Index < 20	ASTM E84
<b>Chemical behaviour</b>	-	-	Do not contribute to corrosion of stainless steel No short term water absorption by partial immersion (WS1) Water diffusion resistant (MV1)	ASTM C795 EN 1609 EN 12086
<b>Application field</b>	-	-	Product for use in technical applications, such as big diameter pipes, tanks and vessels	EN 14303
<b>Material</b>	-	-	Glass mineral wool roll with a crimped fiber structure in black colour With quality marks EUCEB and RAL by the Gütegemeinschaft Mineralwolle e. V., unriskey regarding health according to German decree on dangerous substances, decree on prohibition of chemicals and to regulation EC No 1272/2008 Note Q	CINI 2.1.02
<b>Facing</b>	-	-	On request: Reinforced aluminium facing (Alu1)	-
<b>Quality management</b>	-	-	CE-marked according to EN 14303 ISOVER is certified according to EN ISO 9001 and EN ISO 14001	EN 14303 EN ISO 9001 EN ISO 14001
<b>Miscellaneous</b>	-	-	MW-EN14303-T3-ST (+/250)350-WS1-MV1 Storage: Bags to be stored indoors in a dry and clean place away from source of humidity	EN 14303

Delivery form: Standard dimensions / packaging information*			
<b>Thickness d [mm]</b>	60	80	100
<b>Length l [mm]</b>	7,000	6,000	5,000
<b>Width b [mm]</b>	1,200	1,200	1,200
<b>Unit/pack</b>	1 roll	1 roll	1 roll
<b>m<sup>2</sup>/pack</b>	8.40	7.20	6.00
<b>Packs/pallet</b>	12	12	12
<b>m<sup>2</sup>/pallet</b>	100.80	86.40	72.00

\* all dimensions require minimum order quantities / other dimensions on request



# TECH Crimped Roll 2.0 Alu1

## Light and flexible industry glass mineral wool roll with crimped fiber structure

TECH Crimped Roll 2.0 is a flexible and light weight glass mineral wool roll solution for thermal and acoustic insulation of various industry insulation equipment such as big diameter pipes, tanks and vessels. Due to the crimped fiber structure the compressive strength is improved while maintaining a classic-plus thermal performance. TECH Crimped Roll 2.0 can be used for service temperatures up to 350 °C. On request with reinforced aluminium facing (Alu1).



### Fast installation

Flexibility, lightweight and compressibility helps to handle and install the product easier and faster



### Mechanical resistance

Improved compressive-strength for better mechanical behaviour and lower weight through crimped, non-linear fiber structure



### Thermal insulation

Classic-Plus thermal insulation performance for service temperatures up to 350 °C



### Fire reaction

Non-combustible, Euroclass A1 for effective fire protection on industry sites



### Lightweight

Lightweight solution with up to 50 % weight savings compared to standard insulation solutions



### Sound absorption

Up to 95 % of sound energy absorbed due to optimal longitudinal air flow resistance and uniform porosity values



### Thermal Efficiency Indicator

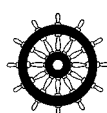
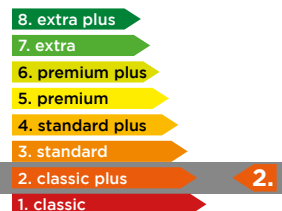

# TECH Crimped Roll 2.0 Alu1



**Light and flexible industry glass mineral wool roll with crimped fiber structure**

Characteristic	Symbol	Unit	Quantities and declared values	Standard
<b>Thermal behaviour</b>	T	[°C]	350 (under 250 Pa)	EN 14706
<b>Thermal conductivity</b>	T	[°C]	50    100    150    200    250    300	EN 12667 ISO 13787
		[W/(m•K)]	0.042    0.053    0.067    0.083    0.104    0.125	
<b>Fire protection / Behaviour in fire</b>	-	-	Non combustible; Euroclass A1	EN 13501-1
			Fire Spread Index = 0; Smoke Development Index < 20	ASTM E84
<b>Chemical behaviour</b>	-	-	Do not contribute to corrosion of stainless steel No short term water absorption by partial immersion (WS1) Water diffusion resistant (MV1)	ASTM C795 EN 1609 EN 12086
<b>Application field</b>	-	-	Product for use in technical applications, such as big diameter pipes, tanks and vessels	EN 14303
<b>Material</b>	-	-	Glass mineral wool roll with a crimped fiber structure in black colour With quality marks EUCEB and RAL by the Gütegemeinschaft Mineralwolle e. V., unriskey regarding health according to German decree on dangerous substances, decree on prohibition of chemicals and to regulation EC No 1272/2008 Note Q	CINI 2.1.02
<b>Facing</b>	-	-	On request: Reinforced aluminium facing (Alu1)	-
<b>Quality management</b>	-	-	CE-marked according to EN 14303 ISOVER is certified according to EN ISO 9001 and EN ISO 14001	EN 14303 EN ISO 9001 EN ISO 14001
<b>Miscellaneous</b>	-	-	MW-EN14303-T3-ST (+/250)350-WS1-MV1 Storage: Bags to be stored indoors in a dry and clean place away from source of humidity	EN 14303

Delivery form: Standard dimensions / packaging information*			
<b>Thickness d [mm]</b>	30	40	50
<b>Length l [mm]</b>	12,000	9,000	8,000
<b>Width b [mm]</b>	1,200	1,200	1,200
<b>Unit/pack</b>	1 roll	1 roll	1 roll
<b>m<sup>2</sup>/pack</b>	14.40	10.80	9.60
<b>Packs/pallet</b>	12	12	12
<b>m<sup>2</sup>/pallet</b>	172.80	129.60	115.20

\* all dimensions require minimum order quantities / other dimensions on request



# TECH Roll 2.0 Alu2

## Ultra-light and flexible glass mineral wool rolls

TECH Roll 2.0 is the highly-flexible and ultra-light weight glass mineral wool solution for thermal and acoustic insulation of various industry insulation equipment such as tanks and vessels, exhaust ducts and stacks. TECH Roll 2.0 can be used for service temperatures up to 200 °C. On request with reinforced aluminium facing (Alu2) for service temperatures up to 250 °C.



### Fast installation

Flexibility, lightweight and compressibility helps to handle and install the product easier and faster



### Thermal insulation

Classic-Plus thermal insulation performance for service temperatures up to 200 °C



### Sound absorption

Up to 95 % of sound energy absorbed due to optimal longitudinal air flow resistance and uniform porosity values



### Fire reaction

Non-combustible, Euroclass A1 for effective fire protection on industry sites



### Improved logistics

Transport and storage savings with up to 80 % more material per pallet than standard solutions



### Lightweight

Lightweight solution with up to 50 % weight savings compared to standard insulation solutions



### Thermal Efficiency Indicator

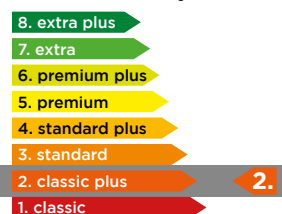



## Ultra-light and flexible glass mineral wool rolls

Characteristic	Symbol	Unit	Quantities and declared values				Standard
<b>Thermal behaviour Max. service temp.</b>	T	[°C]	200 (under 250 Pa) 250 (under 250 Pa) for Alu2				EN 14706
<b>Thermal conductivity</b>	T	[°C]	50	100	150	200	EN 12667 ISO 13787
		[W/(m•K)]	0.042	0.053	0.067	0.083	
<b>Specific thermal capacity</b>	c	[kJ/(kg•K)]	1.03				ISO 10456
<b>Fire protection / Behaviour in fire</b>	-	-	Non combustible; Euroclass A1 Euroclass A2-s1, d0 for TECH Roll 2.0 Alu2				EN 13501-1
<b>Chemical behaviour</b>	-	-	AS-Quality Do not contribute to corrosion of stainless steel No short term water absorption by partial immersion (WS1)				AGI Q 132 ASTM C795 EN 1609
<b>Application field</b>	-	-	Product for use in technical applications, such as tanks and vessels, exhaust ducts and stacks, with need for: thermal and/or acoustic insulation performances especially at ambient to medium temperatures				EN 14303
<b>Material</b>	-	-	Ultra-light and flexible glass mineral wool roll for industry applications With quality marks EUCEB and RAL by the Gütegemeinschaft Mineralwolle e. V., unriskey regarding health according to German decree on dangerous substances, decree on prohibition of chemicals and to regulation EC No 1272/2008 Note Q				CINI 2.1.02
<b>Facing</b>	-	-	On request: Reinforced aluminium facing (Alu2)				-
<b>Quality management</b>	-	-	CE-marked according to EN 14303 ISOVER is certified according to EN ISO 9001 and EN ISO 14001				EN 14303 EN ISO 9001 EN ISO 14001
<b>Miscellaneous</b>	-	-	MW-EN 14303-T2-ST(+/250)200-WS1				EN 14303
<b>Delivery form</b>	-	-	Please contact your local ISOVER dealer All dimensions require minimum order quantities				-



# TECH Roll 3.0

## Light and efficient glass mineral wool rolls

TECH Roll 3.0 is the flexible and light weight solution for efficient thermal and acoustic insulation of various industry insulation equipment such as tanks and vessels, exhaust ducts and stacks. TECH Roll 3.0 can be used for service temperatures up to 300 °C.



### Cost effective solution

Standard thermal performance combined with lightweight provides installation time saving and less heat loss costs



### Thermal insulation

Standard thermal insulation performance for service temperatures up to 300 °C



### Sound absorption

Up to 95 % of sound energy absorbed due to optimal longitudinal air flow resistance and uniform porosity values



### Fire reaction

Non-combustible, Euroclass A1 for effective fire protection on industry sites



### Fast installation

Flexibility, lightweight and compressibility helps to handle and install the product easier and faster



### Improved logistics

Transport and storage savings with up to 80 % more material per pallet than standard solutions



### Thermal Efficiency Indicator

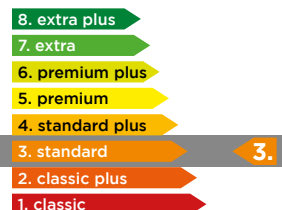



## Light and efficient glass mineral wool rolls

Characteristic	Symbol	Unit	Quantities and declared values	Standard
<b>Thermal behaviour</b> Max. service temp.	T	[°C]	300 (under 250 Pa)	EN 14706
<b>Thermal conductivity</b>	T	[°C]	50    100    150    200    250    300	EN 12667 ISO 13787
		[W/(m•K)]	0.038    0.047    0.058    0.070    0.085    0.102	
<b>Specific thermal capacity</b>	c	[kJ/(kg•K)]	1.03	ISO 10456
<b>Fire protection / Behaviour in fire</b>	-	-	Non combustible; Euroclass A1	EN 13501-1
<b>Chemical behaviour</b>	-	-	AS-Quality Do not contribute to corrosion of stainless steel No short term water absorption by partial immersion (WS1)	AGI Q 132 ASTM C795 EN 1609
<b>Application field</b>	-	-	Product for use in technical applications, such as tanks and vessels, exhaust ducts and stacks, with need for: thermal and/or acoustic insulation performances especially at medium temperatures	EN 14303
<b>Material</b>	-	-	Light and efficient glass mineral wool roll for industry applications With quality marks EUCEB and RAL by the Gütegemeinschaft Mineralwolle e. V., unrisky regarding health according to German decree on dangerous substances, decree on prohibition of chemicals and to regulation EC No1272/2008 Note Q	CINI 2.1.02
<b>Facing</b>	-	-	-	-
<b>Quality management</b>	-	-	CE-marked according to EN 14303 ISOVER is certified according to EN ISO 9001 and EN ISO 14001	EN 14303 EN ISO 9001 EN ISO 14001
<b>Miscellaneous</b>	-	-	EMW-EN 14303-T2-ST(+/250)300-WS1	EN 14303

Delivery form: Standard dimensions / packaging information*				
<b>Thickness d [mm]</b>	30	40	50	60
<b>Width b [mm]</b>	1,200	1,200	1,200	1,200
<b>Length l [mm]</b>	17,500	13,000	11,000	10,000
<b>m<sup>2</sup>/pack</b>	21.00	15.60	13.20	10.00
<b>m<sup>2</sup>/pallet</b>	252.00	187.20	158.40	144.00
<b>Rolls/pack</b>	1	1	1	1
<b>Packs/pallet</b>	12	12	12	12

\* all dimensions require minimum order quantities / other dimensions on request



# U TECH Roll 2.0 Alu1/V1/V2

## The ULTIMATE solution for ultra-light, flexible insulation rolls

ULTIMATE U TECH Roll 2.0 is the ultra-light and highly flexible alternative to classic industry slabs and wired mats. The ULTIMATE roll is designed to combine classic thermal and acoustic insulation performance with ultra-light weight and maximum flexibility for surface temperatures of up to 360 °C giving the possibility to reduce the total weight of insulation constructions significantly. With insulation thicknesses above 200 mm it allows to reduce the number of insulation layers and therefore total installation time drastically making it a cost-effective and efficient insulation solution. U TECH Roll 2.0 is produced in AS-Quality (Cl- ≤ 10 ppm) for usage in contact with austenitic steel structures. On request with yellow (V1) or black glass veil facing (V2) and reinforced aluminium facing (Alu1).



### Fast installation

Flexibility, lightweight and compressibility helps to handle and install the product easier and faster



### Thermal insulation

Classic-Plus thermal performance for service temperatures up to 360 °C with up to 35 % better efficiency than standard solutions



### Improved logistics

Transport and storage savings with up to 80 % more material per pallet than standard solutions



### Fire reaction

Non-combustible, Euroclass A1 for effective fire protection on industry sites



### Sound absorption

Up to 95 % of sound energy absorbed due to optimal longitudinal air flow resistance and uniform porosity values



### Lightweight

Lightweight solution with up to 50 % weight savings compared to standard insulation solutions



#### Thermal Efficiency Indicator

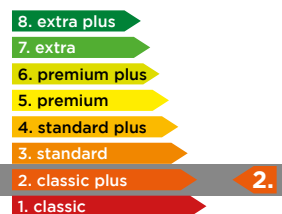



## The ULTIMATE solution for ultra-light, flexible insulation rolls

Characteristic	Symbol	Unit	Quantities and declared values						Standard
<b>Thermal behaviour Max. service temp.</b>	T	[°C]	360 (under 100 Pa)						EN 14706
			650						ASTM C411
<b>Thermal conductivity</b>	T	[°C]	10	50	100	150	200	300	EN 12667 ISO 13787
		[W/(m•K)]	0.034	0.040	0.049	0.062	0.080	0.124	
<b>Specific thermal capacity</b>	c	[kJ/(kg•K)]	1.03						ISO 10456
<b>Fire protection / Behaviour in fire</b>	-	-	Non combustible; Euroclass A1						EN 13501-1
			Fire Spread Index = 0; Smoke Development Index < 20 Fire Spread Index ≤ 2; Smoke Development Index ≤ 25 for U TECH Roll 2.0 Alu1						ASTM E84
<b>Chemical behaviour</b>	-	-	AS-Quality Leachable chloride content less than 10 ppm (CL10) Do not contribute to corrosion of stainless steel No short term water absorption by partial immersion for U TECH Roll 2.0 Si (WS1)						AGI Q 132 EN 13468 ASTM C795 EN 1609
<b>Application field</b>	-	-	Product for use in technical applications, such as tanks and vessels, exhaust ducts and stacks or other equipment with need for good thermal and/or acoustic insulation at standard process temperatures						EN 14303
<b>Material</b>	-	-	ULTIMATE mineral wool flexible roll With quality marks EUCEB and RAL by the Gütegemeinschaft Mineralwolle e. V., unrisky regarding health according to German decree on dangerous substances, decree on prohibition of chemicals and to regulation EC No 1272/2008 Note Q						CINI 2.1.02
<b>Facing</b>	-	-	On request: Reinforced aluminium facing (Alu1) Yellow or black glass veil facing (V1/V2)						-
<b>Quality management</b>	-	-	CE-marked according to EN 14303 ISOVER is certified according to EN ISO 9001 and EN ISO 14001						EN 14303 EN ISO 9001 EN ISO 14001
<b>Miscellaneous</b>	-	-	Insulating material identification number: 10.06.01.99.02 For "Alu1" version, MW-EN 14303-T2-ST(+/100)360-CL10-MV2 For other versions, MW-EN 14303-T2-ST(+/100)360-CL10- AF11						AGI Q 132 EN 14303

Delivery form: Standard dimensions / packaging information*						
<b>Thickness d (mm)</b>	30	40	50	60	80	100
<b>Width b (mm)</b>	600	600	600	600	600	600
<b>Length l (m)</b>	15.00	11.00	9.00	7.50	5.50	4.50
<b>m<sup>2</sup>/pack</b>	18.00	13.20	10.80	9.00	6.60	5.40
<b>m<sup>2</sup>/pallet</b>	324.00	237.60	194.40	162.00	118.80	97.20
<b>rolls/pack</b>	2	2	2	2	2	2
<b>packs/pallet</b>	18	18	18	18	18	18

\* all dimensions require minimum order quantities / other dimensions on request



# U TECH Roll MT 4.0 Alu1/V1/V2

## The **ULTIMATE** solution for light and efficient insulation rolls

ULTIMATE U TECH Roll MT 4.0 is the flexible and light alternative to standard industry slabs and wired mats. The **ULTIMATE** roll is designed to combine standard-plus thermal and acoustic insulation performance with light weight and flexibility of a highly-compressed roll for insulation for maximum service temperatures of up to 460 °C - making the transport and installation fast, efficient and as easy as possible. U TECH Roll MT 4.0 is produced in AS-Quality (Cl- ≤ 10 ppm) for usage when in contact with austenitic steel structures. On request with yellow (V1) or black glass veil facing (V2) and reinforced aluminium facing (Alu1).



### Cost effective solution

Standard-Plus thermal performance combined with lightweight provides installation time saving and less heat loss costs



### Thermal insulation

Standard-Plus thermal performance for service temperatures up to 460 °C with up to 35 % better efficiency than standard solutions



### Sound insulation

The ability of mineral wool to act as a spring results in reducing vibration and noise emissions in industrial processes



### Fire reaction

Non-combustible, Euroclass A1 for effective fire protection on industry sites



### Fast installation

Flexibility, lightweight and compressibility helps to handle and install the product easier and faster



### Improved logistics

Transport and storage savings with up to 80 % more material per pallet than standard solutions



### Thermal Efficiency Indicator

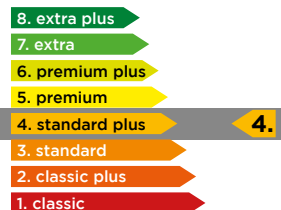



## The ULTIMATE solution for light and efficient insulation rolls

Characteristic	Symbol	Unit	Quantities and declared values							Standard
Thermal behaviour Max. service temp.	T	[°C]	460 (under 250 Pa)							EN 14706
			650							ASTM C411
Thermal conductivity	T	[°C]	10	50	100	150	200	300	400	EN 12667
		[W/(m•K)]	0.032	0.036	0.042	0.051	0.060	0.086	0.122	ISO 13787
Specific thermal capacity	c	[kJ/(kg•K)]	1.03							ISO 10456
Fire protection / Behaviour in fire	-	-	Non combustible; Euroclass A1							EN 13501-1
			Fire Spread Index = 0; Smoke Development Index < 20 Fire Spread Index ≤ 25; Smoke Development Index ≤ 25 for U TECH Roll MT 4.0 Alu1							ASTM E84
Chemical behaviour	-	-	AS-Quality Leachable chloride content less than 10 ppm (CL10) Do not contribute to corrosion of stainless steel No short term water absorption by partial immersion for U TECH Roll MT 4.0 Si (WS1)							AGI Q 132 EN 13468 ASTM C795 EN 1609
Application field	-	-	Product for use in technical applications, such as tanks and vessels, exhaust ducts and stacks with need for good thermal and/or acoustic insulation at medium process temperatures							EN 14303
Material	-	-	ULTIMATE mineral wool flexible roll With quality marks EUCEB and RAL by the Gütegemeinschaft Mineralwolle e. V., unrisky regarding health according to German decree on dangerous substances, decree on prohibition of chemicals and to regulation EC No 1272/2008 Note Q							CINI 2.1.02
Facing	-	-	On request: Reinforced aluminium facing (Alu1) Yellow or black glass veil facing (V1/V2)							-
Quality management	-	-	CE-marked according to EN 14303 ISOVER is certified according to EN ISO 9001 and EN ISO 14001							EN 14303 EN ISO 9001 EN ISO 14001
Miscellaneous	-	-	Insulating material identification number: 10.06.03.99.04 For "Alu1" version, MW-EN 14303-T2-ST(+/250)460-CL10-MV2 For other versions, MW-EN 14303-T2-ST(+/250)460-CL10- AF25							AGI Q 132 EN 14303

Delivery form: Standard dimensions / packaging information*						
Thickness d (mm)	30	40	50	60	80	100
Width b (mm)	600	600	600	600	600	600
Length l (mm)	8,400	6,300	5,000	4,200	3,000	2,500
m <sup>2</sup> /pack	10.08	7.56	6.00	5.04	3.84	3.00
m <sup>2</sup> /pallet	181.44	136.08	108.00	90.72	69.12	54.00
slabs/pallet	2	2	2	2	2	2
packs/pallet	18	18	18	18	18	18

\* all dimensions require minimum order quantities / other dimensions on request



# TECH Slab 2.0 Alu1/V1

## Ultra-light and flexible glass mineral wool slabs for thermo-acoustics

TECH Slab 2.0 is the ultra-light and flexible glass mineral wool solution for thermal and acoustic insulation of various industry insulation equipment such as tanks and vessels, exhaust ducts and stacks. TECH Slab 2.0 can be used for service temperatures up to 175 °C. On request with yellow glass veil facing (V1) or reinforced aluminium facing (Alu1).



### Fast installation

Flexibility, lightweight and compressibility helps to handle and install the product easier and faster



### Thermal insulation

Classic-Plus thermal insulation performance for service temperatures up to 175 °C



### Improved logistics

Transport and storage savings with up to 80 % more material per pallet than standard solutions



### Fire reaction

Non-combustible, Euroclass A1 for effective fire protection on industry sites



### Lightweight

Lightweight solution with up to 50 % weight savings compared to standard insulation solutions



### Sound absorption

Up to 95 % of sound energy absorbed due to optimal longitudinal air flow resistance and uniform porosity values



### Thermal Efficiency Indicator

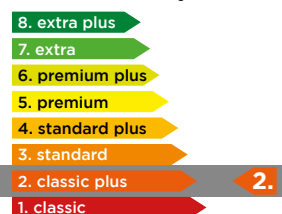



## Ultra-light and flexible glass mineral wool slabs for thermo-acoustics

Characteristic	Symbol	Unit	Quantities and declared values				Standard
<b>Thermal behaviour Max. service temp.</b>	T	[°C]	175 (under 500 Pa)				EN 14706
<b>Thermal conductivity</b>	T	[°C]	50	100	150	170	EN 12667 ISO 13787
		[W/(m•K)]	0.042	0.054	0.068	0.074	
<b>Specific thermal capacity</b>	c	[kJ/(kg•K)]	1.03				ISO 10456
<b>Fire protection / Behaviour in fire</b>	-	-	Non combustible; Euroclass A1				EN 13501-1
			Fire Spread Index = 0; Smoke Development Index < 20				ASTM E84
<b>Chemical behaviour</b>	-	-	AS-Quality Do not contribute to corrosion of stainless steel No short term water absorption by partial immersion (WS1)				AGI Q 132 ASTM C795 EN 1609
<b>Application field</b>	-	-	Product for use in technical applications, such as tanks and vessels, exhaust ducts and stacks or other equipment with need for basic thermal and/or acoustic insulation at low process temperatures				EN 14303
<b>Material</b>	-	-	Glass mineral wool flexible board With quality marks EUCEB, unrisky regarding health according to regulation EC No1272/2008 Note Q				CINI 2.1.01
<b>Facing</b>	-	-	On request: Yellow glass veil facing (V1) Reinforced aluminium facing (Alu1)				-
<b>Quality management</b>	-	-	CE-marked according to EN 14303 ISOVER is certified according to EN ISO 9001 and EN ISO 14001				EN 14303 EN ISO 9001 EN ISO 14001
<b>Miscellaneous</b>	-	-	MW-EN 14303-T4-WS1				EN 14303
<b>Delivery form</b>	-	-	Please contact your local ISOVER dealer All dimensions require minimum order quantities				-



# TECH Slab 2.1 v1/v2

## Classic performance stone mineral wool slabs for thermo-acoustics

TECH Slab 2.1 is the lower weight stone mineral wool slab for classic thermal and acoustic insulation in industry applications such as tanks vessels, exhaust ducts and stacks and other industry equipments with a maximum service temperature of up to 300 °C. When in contact with austenitic steel structures. On request with yellow (V1) or black glass veil facing (V2).



### Fast installation

Flexibility, lightweight and compressibility helps to handle and install the product easier and faster



### Sound absorption

Up to 95 % of sound energy absorbed due to optimal longitudinal air flow resistance and uniform porosity values



### Fire reaction

Non-combustible, Euroclass A1 for effective fire protection on industry sites



### Nuclear plant quality

Certified for use in nuclear applications



### Thermal insulation

Classic-Plus thermal insulation performance for service temperatures up to 300 °C

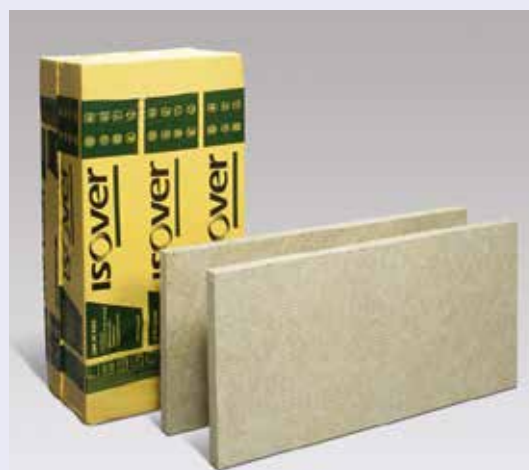

### Thermal Efficiency Indicator

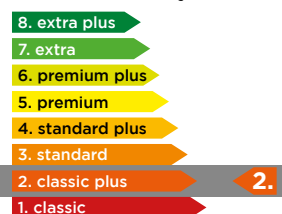



## Classic performance stone mineral wool slabs for thermo-acoustics

Characteristic	Symbol	Unit	Quantities and declared values	Standard
<b>Thermal behaviour</b> Max. service temp.	T	[°C]	300 (under 500 Pa)	EN 14706
<b>Thermal conductivity</b>	T	[°C]	50      100      150      200      300	EN 12667 ISO 13787
		[W/(m•K)]	0.043      0.053      0.066      0.082      0.124	
<b>Specific thermal capacity</b>	c	[kJ/(kg•K)]	1.03	ISO 10456
<b>Fire protection / Behaviour in fire</b>	-	-	Non combustible; Euroclass A1	EN 13501-1
			Fire Spread Index = 0; Smoke Development Index < 20 Fire Spread Index ≤ 25; Smoke Development Index ≤ 25 on the faced side	ASTM E84
<b>Chemical behaviour</b>	-	-	AS-Quality Do not contribute to corrosion of stainless steel No short term water absorption by partial immersion (WS1)	AGI Q 132 ASTM C795 EN 1609
<b>Application field</b>	-	-	Product for use in technical applications, such as tanks vessels, exhaust ducts and stacks or equipment with need for basic thermal and/or acoustic insulation (V2 version) Certified for use in nuclear applications (PMUC 09-0012)	EN 14303 PMUC 09-0012
<b>Material</b>	-	-	Stone mineral wool light board With quality marks EUCEB, unrisky regarding health according to regulation EC No 1272/2008 Note Q	CINI 2.2.01
<b>Facing</b>	-	-	On request: Yellow or black glass veil facing (V1/V2)	-
<b>Quality management</b>	-	-	CE-marked according to EN 14303 ISOVER is certified according to EN ISO 9001 and EN ISO 14001	EN 14303 EN ISO 9001 EN ISO 14001
<b>Miscellaneous</b>	-	-	MW-EN 14303-T4-ST(+)-300-WS1	EN 14303
<b>Delivery form</b>	-	-	Please contact your local ISOVER dealer All dimensions require minimum order quantities	-



# TECH Slab 3.0

## Light and efficient glass mineral wool slabs for thermo-acoustics

TECH Slab 3.0 is the efficient and light glass mineral wool solution for thermal and acoustic insulation of various industry insulation equipment such as tanks vessels, exhaust ducts and stacks. TECH Slab 3.0 can be used for service temperatures up to 300 °C.



### Cost effective solution

Standard thermal performance combined with lightweight provides installation time saving and less heat loss costs



### Thermal insulation

Standard thermal insulation performance for service temperatures up to 300 °C



### Improved logistics

Transport and storage savings with up to 80 % more material per pallet than standard solutions



### Fire reaction

Non-combustible, Euroclass A1 for effective fire protection on industry sites



### Fast installation

Flexibility, lightweight and compressibility helps to handle and install the product easier and faster



### Sound absorption

Up to 95 % of sound energy absorbed due to optimal longitudinal air flow resistance and uniform porosity values



### Thermal Efficiency Indicator





## Light and efficient glass mineral wool slabs for thermo-acoustics

Characteristic	Symbol	Unit	Quantities and declared values	Standard				
<b>Thermal behaviour Max. service temp.</b>	T	[°C]	300 (under 500 Pa)	EN 14706				
<b>Thermal conductivity</b>	T	[°C]	50	100	150	200	300	EN 12667 ISO 13787
		[W/(m•K)]	0.038	0.047	0.058	0.070	0.102	
<b>Specific thermal capacity</b>	c	[kJ/(kg•K)]	1.03					ISO 10456
<b>Fire protection / Behaviour in fire</b>	-	-	Non combustible; Euroclass A1					EN 13501-1
			Fire Spread Index = 0; Smoke Development Index < 20					ASTM E84
<b>Chemical behaviour</b>	-	-	AS-Quality Do not contribute to corrosion of stainless steel No short term water absorption by partial immersion (WS1)					AGI Q 132 ASTM C795 EN 1609
<b>Application field</b>	-	-	Product for use in technical applications, such as tanks and vessels, exhaust ducts and stacks or other equipment with need for good thermal insulation at medium process temperatures					EN 14303
<b>Material</b>	-	-	Glass mineral wool board With quality marks EUCEB, unrisky regarding health according to regulation EC No 1272/2008 Note Q					CINI 2.1.01
<b>Facing</b>	-	-	-					-
<b>Quality management</b>	-	-	CE-marked according to EN 14303 ISOVER is certified according to EN ISO 9001 and EN ISO 14001					EN 14303 EN ISO 9001 EN ISO 14001
<b>Miscellaneous</b>	-	-	MW-EN 14303-T3-ST(+)-300-WS1					EN 14303
<b>Delivery form</b>	-	-	Please contact your local ISOVER dealer All dimensions require minimum order quantities Standard width: 500 mm 600 mm 1,000 mm Standard thickness range: 30 mm until 120 mm Other dimensions on request					-



# TECH Slab 3.0 G1

## Light and efficient glass mineral wool slabs for thermo-acoustics

TECH Slab 3.0 G1 is an efficient and light glass mineral wool solution for thermal and acoustic insulation of various industry insulation equipment such as tanks vessels, exhaust ducts and stacks. The glass-fabric facing provides additional acoustic properties and mechanical surface strength. TECH Slab 3.0 G1 can be used for service temperatures up to 300 °C.



### Cost effective solution

Standard thermal performance combined with lightweight provides installation time saving and less heat loss costs



### Sound absorption

Up to 95 % of sound energy absorbed due to optimal longitudinal air flow resistance and uniform porosity values



### Thermal insulation

Standard thermal insulation performance for service temperatures up to 300 °C



### Improved logistics

Transport and storage savings with up to 80 % more material per pallet than standard solutions



### Fast installation

Flexibility, lightweight and compressibility helps to handle and install the product easier and faster



### Lightweight

Lightweight solution with up to 50 % weight savings compared to standard insulation solutions

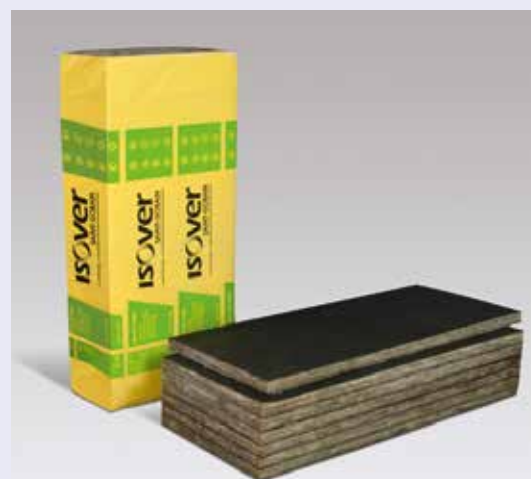

### Thermal Efficiency Indicator

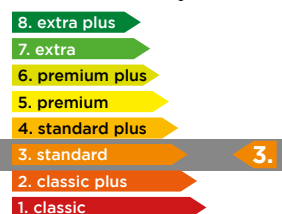



## Light and efficient glass mineral wool slabs for thermo-acoustics

Characteristic	Symbol	Unit	Quantities and declared values	Standard				
<b>Thermal behaviour</b> Max. service temp.	T	[°C]	300 (under 500 Pa)	EN 14706				
<b>Thermal conductivity</b>	T	[°C]	50	100	150	200	300	EN 12667 ISO 13787
		[W/(m•K)]	0.038	0.047	0.058	0.070	0.102	
<b>Specific thermal capacity</b>	c	[kJ/(kg•K)]	1.03					ISO 10456
<b>Fire protection / Behaviour in fire</b>	-	-	Euroclass A2-s1, d0					EN 13501-1
<b>Chemical behaviour</b>	-	-	AS-Quality Do not contribute to corrosion of stainless steel No short term water absorption by partial immersion (WS1)					AGI Q 132 ASTM C795 EN 1609
<b>Acoustic behavior</b>	w	-	From 0.3 to 0.9 (depending on thickness)					
<b>Application field</b>	-	-	Product for use in technical applications, such as tanks and vessels, exhaust ducts and stacks or other equipment with need for basic thermal and/or acoustic insulation at low process temperatures					EN 14303
<b>Material</b>	-	-	Glass mineral wool board With quality marks EUCEB, unrisky regarding health according to regulation EC No 1272/2008 Note Q					CINI 2.1.01
<b>Facing</b>	-	-	On request: Black glass fabric facing (G1)					-
<b>Quality management</b>	-	-	CE-marked according to EN 14303 ISOVER is certified according to EN ISO 9001 and EN ISO 14001					EN 14303 EN ISO 9001 EN ISO 14001
<b>Miscellaneous</b>	-	-	MW-EN 14303-T4-ST(+)-300-WS1					EN 14303

Delivery form: Standard dimensions / packaging information*			
<b>Thickness d [mm]</b>	30	40	50
<b>Width b [mm]</b>	600	600	600
<b>Length l [mm]</b>	1,350	1,350	1,350
<b>m<sup>2</sup>/pack</b>	11.34	8.10	6.48
<b>m<sup>2</sup>/pallet</b>	181.44	129.60	103.68
<b>m<sup>2</sup>/truck</b>	3,266	2,333	1,866

\* all dimensions require minimum order quantities / other dimensions on request



# TECH Slab MT 2.2 V2

## Acoustic absorption for industrial machinery and equipment

TECH Slab MT 2.2 is the semi-rigid stone mineral wool slab for the insulation of industry tanks and vessels, exhaust ducts and stacks with a maximum service temperature of up to 560 °C. Good acoustic absorption and mechanical handling. On request with black glass veil facing (V2).



### Sound absorption

Up to 95 % of sound energy absorbed due to optimal longitudinal air flow resistance and uniform porosity values



### Fire reaction

Non-combustible, Euroclass A1 for effective fire protection on industry sites



### High service temperatures

Especially designed for high service temperatures up to 560 °C



### Thermal insulation

Classic-Plus thermal insulation performance for service temperatures up to 560 °C



### Thermal Efficiency Indicator





## Acoustic absorption for industrial machinery and equipment

Characteristic	Symbol	Unit	Quantities and declared values						Standard
<b>Thermal behaviour</b>	T	[°C]	560 (under 500 Pa)						EN 14706
<b>Thermal conductivity</b>	T	[°C]	50	100	150	200	300	400	EN 12667 ISO 13787
		[W/(m•K)]	0.043	0.051	0.063	0.076	0.113	0.164	
<b>Specific thermal capacity</b>	c	[kJ/(kg•K)]	1.03						ISO 10456
<b>Fire protection / Behaviour in fire</b>	-	-	Non combustible; Euroclass A1						EN 13501-1
			Fire Spread Index = 0; Smoke Development Index < 20 Fire Spread Index ≤ 25; Smoke Development Index ≤ 25 on the faced side						ASTM E84
<b>Chemical behaviour</b>	-	-	AS-Quality Do not contribute to corrosion of stainless steel No short term water absorption by partial immersion (WS1)						AGI Q 132 ASTM C795 EN 1609
<b>Application field</b>	-	-	Product for use in technical applications, such as tanks and vessels, exhaust ducts and stacks or equipment with need for basic thermal at high temperatures and acoustic insulation						EN 14303
<b>Material</b>	-	-	Stone mineral wool light board With quality marks EUCEB, unrisky regarding health according to regulation EC No 1272/2008 Note Q						CINI 2.2.01
<b>Facing</b>	-	-	On request: Black glass veil facing (V2)						-
<b>Quality management</b>	-	-	CE-marked according to EN 14303 ISOVER is certified according to EN ISO 9001 and EN ISO 14001						EN 14303 EN ISO 9001 EN ISO 14001
<b>Miscellaneous</b>	-	-	MW-EN 14303-T4-ST(+)-560-WS1						EN 14303

### Delivery form: Standard dimensions / packaging information\*

	30	40	50
<b>Thickness d [mm]</b>			
<b>Length l [mm]</b>	1,200	1,200	1,200
<b>Width b [mm]</b>	600	600	600
<b>m<sup>2</sup>/pack</b>	14.40	11.52	8.64
<b>m<sup>2</sup>/truck</b>	2,534	2,028	1,521

\* all dimensions require minimum order quantities / other dimensions on request



# TECH Slab MT 3.0

## Standard multi-purpose stone mineral wool slabs

TECH Slab MT 3.0 is the medium-weight solid stone mineral wool slab for the insulation of industry tanks and vessels, exhaust ducts and stacks or other equipment with a maximum service temperature of up to 550 °C. It combines standard thermal and acoustic performance. TECH Slab MT 3.0 is available with AS-Quality (Cl- ≤ 10 ppm) when in contact with austenitic steel structures.



### Thermal insulation

Standard thermal insulation performance for service temperatures up to 550 °C



### High service temperatures

Especially designed for high service temperatures up to 550 °C



### Sound insulation

The ability of mineral wool to act as a spring results in reducing vibration and noise emissions in industrial processes



### Fire reaction

Non-combustible, Euroclass A1 for effective fire protection on industry sites



### Sound absorption

Up to 95 % of sound energy absorbed due to optimal longitudinal air flow resistance and uniform porosity values



### Thermal Efficiency Indicator

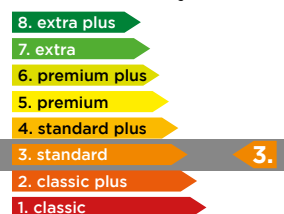



## Standard multi-purpose stone mineral wool slabs

Characteristic	Symbol	Unit	Quantities and declared values							Standard
<b>Thermal behaviour Max. service temp.</b>	T	[°C]	550 (under 500 Pa)							EN 14706
<b>Thermal conductivity</b>	T	[°C]	50	100	150	200	300	400	500	EN 12667 ISO 13787
		[W/(m•K)]	0.039	0.045	0.052	0.063	0.088	0.121	0.162	
<b>Specific thermal capacity</b>	c	[kJ/(kg•K)]	1.03							ISO 10456
<b>Fire protection / Behaviour in fire</b>	-	-	Non combustible; Euroclass A1							EN 13501-1
			Fire Spread Index = 0; Smoke Development Index < 20							ASTM E84
<b>Chemical behaviour</b>	-	-	AS-Quality Leachable chloride content less than 10 ppm (CL10) Do not contribute to corrosion of stainless steel No short term water absorption by partial immersion (WS1)							AGI Q 132 EN 13468 ASTM C795 EN 1609
<b>Acoustic behavior</b>	-	-	Airflow resistivity AF r >30 kPas/m							
<b>Application field</b>	-	-	Product for use in technical applications, such as tanks and vessels, exhaust ducts and stacks or other equipment with need for basic thermal and/or acoustic insulation at medium to high process temperatures							EN 14303
<b>Material</b>	-	-	Stone mineral wool board With quality marks EUCEB and RAL by the Gütegemeinschaft Mineralwolle e. V., unriskey regarding health according to German decree on dangerous substances, decree on prohibition of chemicals and to regulation EC No 1272/2008 Note Q							CINI 2.2.01
<b>Facing</b>	-	-	-							-
<b>Quality management</b>	-	-	CE-marked according to EN 14303 ISOVER is certified according to EN ISO 9001 and EN ISO 14001							EN 14303 EN ISO 9001 EN ISO 14001
<b>Miscellaneous</b>	-	-	Insulating material identification number: 10.07.03.99.07 MW-EN 14303-T4-ST(+ )550-AF30							AGI Q 132 EN 14303
<b>Delivery form</b>	-	-	Please contact your local ISOVER dealer All dimensions require minimum order quantities Standard width: 500 mm 600 mm 1,000 mm Standard thickness range: 30 mm until 120 mm Other dimensions on request							-



# TECH Slab MT 3.1 Alu2/V1

## Standard multi-purpose stone mineral wool slabs

TECH Slab MT 3.1 is the medium-weight solid stone mineral wool slab for the insulation of industry tanks and vessels, exhaust ducts and stacks or other equipments with a maximum service temperature of up to 600 °C. It combines standard thermal and acoustic performance. TECH Slab MT 3.1 is available with AS-Quality (Cl- ≤ 10 ppm) when in contact with austenitic steel structures. On request with yellow glass veil facing (V1) or reinforced aluminium facing (Alu2).



### Thermal insulation

Standard thermal insulation performance for service temperatures up to 600 °C



### High service temperatures

Especially designed for high service temperatures up to 600 °C



### Sound insulation

The ability of mineral wool to act as a spring results in reducing vibration and noise emissions in industrial processes



### Fire reaction

Non-combustible, Euroclass A1 for effective fire protection on industry sites



### Nuclear plant quality

Certified for use in nuclear applications



### Sound absorption

Up to 95 % of sound energy absorbed due to optimal longitudinal air flow resistance and uniform porosity values

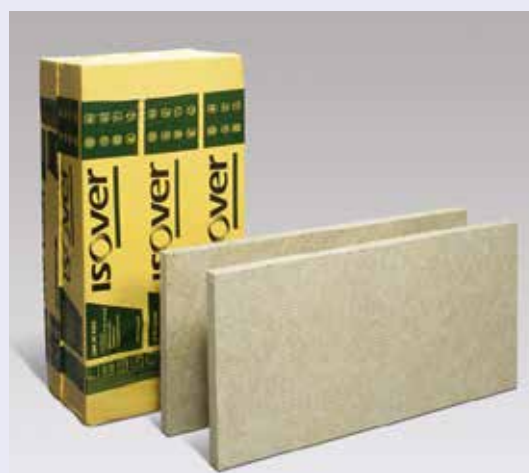

### Thermal Efficiency Indicator

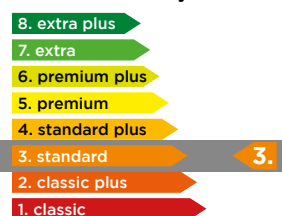



## Standard multi-purpose stone mineral wool slabs

Characteristic	Symbol	Unit	Quantities and declared values								Standard
<b>Thermal behaviour Max. service temp.</b>	T	[°C]	600 (under 500 Pa)								EN 14706
			700								ASTM C411
<b>Thermal conductivity</b>	T	[°C]	50	100	150	200	300	400	500	600	EN 12667 ISO 13787
		[W/(m•K)]	0.041	0.048	0.058	0.068	0.097	0.134	0.183	0.248	
<b>Specific thermal capacity</b>	c	[kJ/(kg•K)]	1.03								ISO 10456
<b>Fire protection / Behaviour in fire</b>	-	-	Non combustible; Euroclass A1 Euroclass A2-s1,d 0 for TECH Slab MT 3.1 Alu2								EN 13501-1
			Fire Spread Index = 0; Smoke Development Index < 20 Fire Spread Index ≤ 25; Smoke Development Index ≤ 25 for TECH Slab MT 3.1 Alu2								ASTM E84
<b>Chemical behaviour</b>	-	-	AS-Quality Do not contribute to corrosion of stainless steel No short term water absorption by partial immersion (WS1)								AGI Q 132 ASTM C795 EN 1609
<b>Application field</b>	-	-	Product for use in technical applications, such as tanks and vessels, exhaust ducts and stacks or other equipment with need for good thermal and/or acoustic insulation at high process temperatures Certified for use in nuclear applications (PMUC 09-0013)								EN 14303 PMUC 09-0013
<b>Material</b>	-	-	Stone mineral wool board With quality marks EUCEB, unrisky regarding health according to regulation EC No 1272/2008 Note Q								CINI 2.2.01
<b>Facing</b>	-	-	On request: Reinforced aluminum foil (Alu2) Yellow glass veil facing (V1)								-
<b>Quality management</b>	-	-	CE-marked according to EN 14303 ISOVER is certified according to EN ISO 9001 and EN ISO 14001								EN 14303 EN ISO 9001 EN ISO 14001
<b>Miscellaneous</b>	-	-	MW-EN 14303-T4-ST(+)-600-WS1								EN 14303

Delivery form: Standard dimensions / packaging information*						
<b>Thickness d [mm]</b>	30	40	50	60	80	100
<b>Width b [mm]</b>	600	600	600	600	600	600
<b>Length l [mm]</b>	1,200	1,200	1,200	1,200	1,200	1,200
<b>m<sup>2</sup>/pack</b>	9.36	7.30	5.76	4.32	3.60	2.88
<b>m<sup>2</sup>/pallet</b>	112.32	86.40	69.12	51.84	43.20	34.56
<b>Packs/pallet</b>	12	12	12	12	12	12

\* all dimensions require minimum order quantities / other dimensions on request



# TECH Slab MT 4.0

## Standard-Plus performance robust stone mineral wool slabs

TECH Slab MT 4.0 is the medium-weight robust stone mineral wool slab for the insulation of industry tanks and vessels, exhaust ducts and stacks or other equipment with a maximum service temperature of up to 620 °C. It combines standard-plus thermal and acoustic performance. TECH Slab MT 4.0 is produced with AS-Quality (Cl- ≤ 10 ppm) for usage when in contact with austenitic steel structures.



### Thermal insulation

Standard-Plus thermal insulation performance for service temperatures up to 620 °C



### High service temperatures

Especially designed for high service temperatures up to 620 °C



### Sound insulation

The ability of mineral wool to act as a spring results in reducing vibration and noise emissions in industrial processes



### Fire reaction

Non-combustible, Euroclass A1 for effective fire protection on industry sites



### Thermal Efficiency Indicator

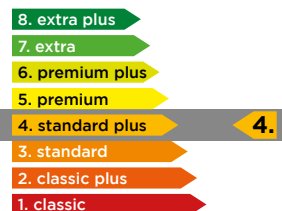



## Standard-Plus performance robust stone mineral wool slabs

Characteristic	Symbol	Unit	Quantities and declared values									Standard
<b>Thermal behaviour Max. service temp.</b>	T	[°C]	620 (under 500 Pa)									EN 14706
			650									ASTM C411
<b>Thermal conductivity</b>	T	[°C]	10	50	100	150	200	300	400	500	600	EN 12667 ISO 13787
		[W/(m•K)]	0.034	0.039	0.045	0.053	0.064	0.088	0.121	0.164	0.219	
<b>Specific thermal capacity</b>	c	[kJ/(kg•K)]	1.03									ISO 10456
<b>Fire protection / Behaviour in fire</b>	-	-	Non combustible; Euroclass A1									EN 13501-1
			Fire Spread Index = 0; Smoke Development Index < 20									ASTM E84
<b>Chemical behaviour</b>	-	-	AS-Quality Leachable chloride content less than 10 ppm (CL10) Do not contribute to corrosion of stainless steel									AGI Q 132 EN 13468 ASTM C795
<b>Application field</b>	-	-	Product for use in technical applications, such as tanks and vessels, exhaust ducts and stacks or other equipment with need for good thermal and/or acoustic insulation at high process temperatures									EN 14303
<b>Material</b>	-	-	With quality marks EUCEB and RAL by the Gütegemeinschaft Mineralwolle e. V., unriskey regarding health according to German decree on dangerous substances, decree on prohibition of chemicals and to regulation EC No 1272/2008 Note Q									CINI 2.2.01
<b>Facing</b>	-	-	-									-
<b>Quality management</b>	-	-	CE-marked according to EN 14303 ISOVER is certified according to EN ISO 9001 and EN ISO 14001									EN 14303 EN ISO 9001 EN ISO 14001
<b>Miscellaneous</b>	-	-	Insulating material identification number: 10.07.03.30.08 MW-EN 14303-T4-ST(+)-620-AF40									AGI Q 132 EN 14303

Delivery form: Standard dimensions / packaging information*						
<b>Thickness d [mm]</b>	30	40	50	60	80	100
<b>Width b [mm]</b>	625	625	625	625	625	625
<b>Length l [mm]</b>	1,200	1,200	1,200	1,200	1,200	1,200
<b>m<sup>2</sup>/pack</b>	7.50	4.50	4.50	3.75	2.25	2.25
<b>m<sup>2</sup>/pallet</b>	90.00	67.50	54.00	45.00	33.75	27.00
<b>Packs/pallet</b>	12	15	12	12	15	12

\* all dimensions require minimum order quantities / other dimensions on request



# TECH Slab MT 4.1 Alu2/V1

## Standard-Plus performance robust stone mineral wool slabs

TECH Slab MT 4.1 is the medium-weight robust stone mineral wool slab for the insulation of industry tanks and vessels, exhaust ducts and stacks or other equipment with a maximum service temperature of up to 640 °C. It combines standard-plus thermal and acoustic performance. TECH Slab MT 4.1 is available with AS-Quality (Cl- ≤ 10 ppm) when in contact with austenitic steel structures. On request with yellow glass veil facing (V1) or reinforced aluminium facing (Alu2).



### Thermal insulation

Standard-Plus thermal insulation performance for service temperatures up to 640 °C



### High service temperatures

Especially designed for high service temperatures up to 640 °C



### Sound insulation

The ability of mineral wool to act as a spring results in reducing vibration and noise emissions in industrial processes



### Fire reaction

Non-combustible, Euroclass A1 for effective fire protection on industry sites



### Mechanical resistance

Robust industry slab for optimal use in applications requiring high mechanical strength, e.g. by foot traffic



### Thermal Efficiency Indicator

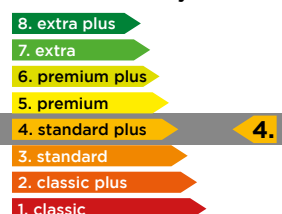



## Standard-Plus performance robust stone mineral wool slabs

Characteristic	Symbol	Unit	Quantities and declared values								Standard
<b>Thermal behaviour Max. service temp.</b>	T	[°C]	640 (under 500 Pa)								EN 14706
			700								ASTM C411
<b>Thermal conductivity</b>	T	[°C]	50	100	150	200	300	400	500	600	EN 12667 ISO 13787
		[W/(m•K)]	0.041	0.047	0.055	0.065	0.089	0.118	0.155	0.201	
<b>Specific thermal capacity</b>	c	[kJ/(kg•K)]	1.03								ISO 10456
<b>Sound absorption*</b>	p	Hz	w	125	250	500	1,000	2,000	4,000	Thickness [mm]	EN ISO 11654 EN ISO 354
		-	1.00	0.26	0.87	1.06	1.04	1.05	1.12	50	
<b>Airflow resistivity*</b>	AFR	kPa-s/m	> 40								ISO 9053-1
<b>Fire protection / Behaviour in fire</b>	-	-	Non combustible; Euroclass A1 Euroclass A2-s1,d0 for TECH Slab MT 4.1 Alu2								EN 13501-1
	-	-	Fire Spread Index = 0; Smoke Development Index < 20 Fire Spread Index ≤ 25; Smoke Development Index ≤ 25 for TECH Slab MT 4.1 Alu2								ASTM E84
<b>Chemical behaviour</b>	-	-	AS-Quality (CL10 according EN 13468 measurement) on request Do not contribute to corrosion of stainless steel No short term water absorption by partial immersion (WS1)								AGI Q 132 EN 13468 ASTM C795 EN 1609
<b>Application field</b>	-	-	Product for use in technical applications, such as tanks and vessels, exhaust ducts and stacks or other equipment with need for good thermal and/or acoustic insulation at high process temperatures								EN 14303
<b>Material</b>	-	-	Stone mineral wool rigid board With quality marks EUCEB, unrisky regarding health according to regulation EC No 1272/2008 Note Q								CINI 2.2.01
<b>Facing</b>	-	-	On request: Reinforced aluminum foil (Alu2) Yellow glass veil facing (V1)								-
<b>Quality management</b>	-	-	CE-marked according to EN 14303 ISOVER is certified according to EN ISO 9001 and EN ISO 14001								EN 14303 EN ISO 9001 EN ISO 14001
<b>Miscellaneous</b>	-	-	MW-EN 14303-T4-ST(+)-640-WS1								EN 14303
<b>Delivery form</b>	-	-	Please contact your local ISOVER dealer All dimensions require minimum order quantities Standard width: 500 mm 600 mm 1,000 mm Standard thickness range: 30 mm until 120 mm Other dimensions on request								-

\* These values proceed from tests conducted in laboratory under certain given conditions. Real life conditions may differ due to various ambient and operational factors. These values are therefore representative and should only be used as a guide for estimation purposes. ISOVER takes no responsibility in the case of not achieving the required acoustical performance.



# TECH Slab MT 5.1

## Premium performance rigid stone mineral wool slabs

TECH Slab MT 5.1 is the rigid stone mineral wool slab for the insulation of industry tanks and vessels, exhaust ducts and stacks or other equipment with a maximum service temperature of up to 660 °C. It combines premium thermal and acoustic performance with mechanical strength. TECH Slab MT 5.1 is available with AS-Quality (Cl- ≤ 10 ppm) when in contact with austenitic steel structures.



### Energy efficiency

Premium thermal insulation performance at medium to higher service temperatures up to 660 °C



### High service temperatures

Especially designed for high service temperatures up to 660 °C



### Sound insulation

The ability of mineral wool to act as a spring results in reducing vibration and noise emissions in industrial processes



### Fire reaction

Non-combustible, Euroclass A1 for effective fire protection on industry sites



### Mechanical resistance

Robust industry slab for optimal use in applications requiring high mechanical strength, e.g. by foot traffic



### Nuclear plant quality

Certified for use in nuclear applications



### Thermal Efficiency Indicator

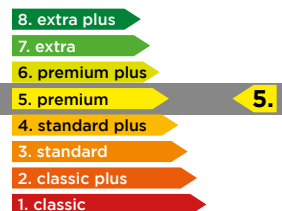



## Premium performance rigid stone mineral wool slabs

Characteristic	Symbol	Unit	Quantities and declared values								Standard
<b>Thermal behaviour Max. service temp.</b>	T	[°C]	660 (under 500 Pa)								EN 14706
			700								ASTM C411
<b>Thermal conductivity</b>	T	[°C]	50	100	150	200	300	400	500	600	EN 12667 ISO 13787
		[W/(m•K)]	0.041	0.047	0.054	0.063	0.084	0.110	0.143	0.182	
<b>Specific thermal capacity</b>	c	[kJ/(kg•K)]	1.03								ISO 10456
<b>Sound absorption*</b>	p	Hz	w	125	250	500	1,000	2,000	4,000	Thickness [mm]	EN ISO 11654 EN ISO 354
		-	1.00	0.28	0.90	1.01	1.01	1.05	1.11	50	
		-	1.00	0.74	0.93	0.92	1.01	1.06	1.15	100	
<b>Airflow resistivity*</b>	AFR	kPa-s/m	> 50								ISO 9053-1
<b>Fire protection / Behaviour in fire</b>	-	-	Non combustible; Euroclass A1								EN 13501-1
			Fire Spread Index = 0; Smoke Development Index < 20								ASTM E84
<b>Chemical behaviour</b>	-	-	AS-Quality (CL10 according EN 13468 measurement) on request Do not contribute to corrosion of stainless steel No short term water absorption by partial immersion (WS1)								AGI Q 132 EN 13468 ASTM C795 EN 1609
<b>Application field</b>	-	-	Product for use in technical applications, such as tanks and vessels, exhaust ducts and stacks or other equipment with need for good thermal and/or acoustic insulation at high process temperatures Certified for use in nuclear applications (PMUC 09-0014)								EN 14303 PMUC 09-0014
<b>Material</b>	-	-	Stone mineral wool rigid board With quality marks EUCEB, unrisky regarding health according to regulation EC No 1272/2008 Note Q								CINI 2.2.01
<b>Facing</b>	-	-	-								-
<b>Quality management</b>	-	-	CE-marked according to EN 14303 ISOVER is certified according to EN ISO 9001 and EN ISO 14001								EN 14303 EN ISO 9001 EN ISO 14001
<b>Miscellaneous</b>	-	-	MW-EN 14303-T4-ST(+)-660-WS1								EN 14303
<b>Delivery form</b>	-	-	Please contact your local ISOVER dealer All dimensions require minimum order quantities Standard width: 500 mm 600 mm 1,000 mm Standard thickness range: 30 mm until 120 mm Other dimensions on request								-

\* These values proceed from tests conducted in laboratory under certain given conditions. Real life conditions may differ due to various ambient and operational factors. These values are therefore representative and should only be used as a guide for estimation purposes. ISOVER takes no responsibility in the case of not achieving the required acoustical performance.



# TECH Slab HT 6.1

## Premium-Plus performance rigid stone mineral wool slabs for high-temperatures

TECH Slab HT 6.1 is the rigid stone mineral wool slab for the insulation of industry tanks and vessels, exhaust ducts and stacks or other equipment with a maximum service temperature of up to 700 °C. It combines premium thermal and acoustic performance with high mechanical strength. TECH Slab HT 6.1 is available with AS-Quality (Cl- ≤ 10 ppm) when in contact with austenitic steel structures.



### Energy efficiency

Premium-Plus thermal insulation performance at medium to higher service temperatures up to 700 °C



### High service temperatures

Especially designed for high service temperatures up to 700 °C



### Thin solution

Personal protection and heat loss requirements achieved with up to 35 % less insulation thickness than standard solutions



### Mechanical resistance

Robust industry slab for optimal use in applications requiring high mechanical strength, e.g. by foot traffic



### Fire reaction

Non-combustible, Euroclass A1 for effective fire protection on industry sites



### Environmental protection

Its Premium-Plus thermal performance allows to reduce significantly energy losses, the use of natural resources and CO<sub>2</sub> emissions



### Thermal Efficiency Indicator

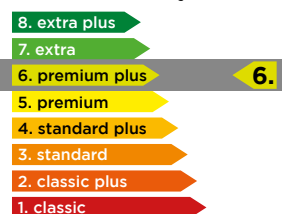



## Premium-Plus performance rigid stone mineral wool slabs for high-temperatures

Characteristic	Symbol	Unit	Quantities and declared values								Standard	
<b>Thermal behaviour Max. service temp.</b>	T	[°C]	700 (under 500 Pa)								EN 14706	
			700								ASTM C411	
<b>Thermal conductivity</b>	T	[°C]	50	100	150	200	300	400	500	600	650	EN 12667 ISO 13787
		[W/(m•K)]	0.039	0.044	0.051	0.058	0.076	0.098	0.123	0.154	0.172	
<b>Specific thermal capacity</b>	c	[kJ/(kg•K)]	1.03								ISO 10456	
<b>Fire protection / Behaviour in fire</b>	-	-	Non combustible; Euroclass A1								EN 13501-1	
			Fire Spread Index = 0; Smoke Development Index < 20								ASTM E84	
<b>Compressive strength</b>	-	-	CS(10)20								EN 826	
<b>Sound absorption*</b>	ρ	Hz	w	125	250	500	1,000	2,000	4,000	Thickness [mm]	EN ISO 11654 EN ISO 354	
		-	0.90	0.20	0.84	0.81	0.90	0.98	1.05	50		
		-	0.90	0.66	0.69	0.82	0.95	1.02	1.09	100		
<b>Airflow resistivity*</b>	AFR	kPa-s/m	> 90								ISO 9053-1	
<b>Chemical behaviour</b>	-	-	AS-Quality Do not contribute to corrosion of stainless steel No short term water absorption by partial immersion (WS1)								AGI Q 132 ASTM C795 EN 1609	
<b>Application Field</b>	-	-	Product for use in technical applications, such as tanks and vessels, exhaust ducts and stacks or other equipment with need for excellent thermal and/or acoustic insulation and compression resistance at high process temperatures								EN 14303	
<b>Material</b>	-	-	Stone mineral wool heavy duty board With quality marks EUCEB, unrisky regarding health according to regulation EC No 1272/2008 Note Q								CINI 2.2.01	
<b>Facing</b>	-	-	-								-	
<b>Quality management</b>	-	-	CE-marked according to EN 14303 ISOVER is certified according to EN ISO 9001 and EN ISO 14001								EN 14303 EN ISO 9001 EN ISO 14001	
<b>Miscellaneous</b>	-	-	MW-EN 14303-T4-ST(+)700-CS(10) 20-WS1								EN 14303	
<b>Delivery form</b>	-	-	Please contact your local ISOVER dealer All dimensions require minimum order quantities Standard width: 500 mm 600 mm 1,000 mm Standard thickness range: 30 mm until 120 mm Other dimensions on request								-	

\* These values proceed from tests conducted in laboratory under certain given conditions. Real life conditions may differ due to various ambient and operational factors. These values are therefore representative and should only be used as a guide for estimation purposes. ISOVER takes no responsibility in the case of not achieving the required acoustical performance.



# U TECH Slab 2.0 Alu1/V1/V2/G1

## The **ULTIMATE** solution for ultra-light, flexible insulation slabs

ULTIMATE U TECH Slab 2.0 is the ultra-light and flexible alternative to classic industry slabs. The ULTIMATE slab is designed to combine classic-plus thermal and acoustic insulation performance with ultra-light weight and flexibility for surface temperatures of up to 360 °C giving the possibility to reduce the total weight and total installed costs of insulation constructions significantly. U TECH Slab 2.0 is produced in AS-Quality (Cl- ≤ 10 ppm) for usage when in contact with austenitic steel structures. On request with yellow (V1) or black glass veil facing (V2) or glass fabric (G1) and reinforced aluminium facing (Alu1).



### Improved logistics

Transport and storage savings with up to 80 % more material per pallet than standard solutions



### Fast installation

Flexibility, lightweight and compressibility helps to handle and install the product easier and faster



### Thermal insulation

Classic-Plus thermal performance for service temperatures up to 360 °C with up to 35 % better efficiency than standard solutions



### Fire reaction

Non-combustible, Euroclass A1 for effective fire protection on industry sites



### Sound absorption

Up to 95 % of sound energy absorbed due to optimal longitudinal air flow resistance and uniform porosity values



### Lightweight

Lightweight solution with up to 50 % weight savings compared to standard insulation solutions



### Thermal Efficiency Indicator

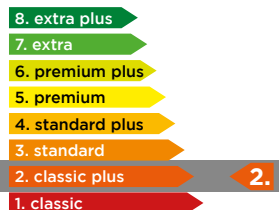



## The ULTIMATE solution for ultra-light, flexible insulation slabs

Characteristic	Symbol	Unit	Quantities and declared values								Standard
<b>Thermal behaviour Max. service temp.</b>	T	[°C]	360 (under 100 Pa)								EN 14706
			650								ASTM C411
<b>Thermal conductivity</b>	T	[°C]	10	50	100	150	200	300			EN 12667
		[W/(m•K)]	0.034	0.040	0.049	0.062	0.080	0.124			ISO 13787
<b>Specific thermal capacity</b>	c	[kJ/(kg•K)]	1.03								ISO 10456
<b>Sound absorption*</b>	p	Hz	w	125	250	500	1,000	2,000	4,000	Thickness [mm]	EN ISO 11654 EN ISO 354
		-	1.00	0.17	0.80	1.03	1.08	1.08	1.10	50	
		-	1.00	0.57	1.19	1.13	1.07	1.06	1.11	100	
<b>Airflow resistivity*</b>	AFR	kPa-s/m	> 10								ISO 9053-1
<b>Fire protection / Behaviour in fire</b>	-	-	Non combustible; Euroclass A1								EN 13501-1
			Fire Spread Index = 0; Smoke Development Index < 20 Fire Spread Index ≤ 25; Smoke Development Index ≤ 25 for U TECH Slab 2.0 Alu1								ASTM E84
<b>Chemical behaviour</b>	-	-	AS-Quality (except for V2 and Si versions) Leachable chloride content less than 10 ppm (CL10 except for V2 & Si) Do not contribute to corrosion of stainless steel No short term water absorption by partial immersion for U TECH Slab 2.0 Si (WS1)								AGI Q 132 EN 13468 ASTM C795 EN 1609
<b>Application field</b>	-	-	Product for use in technical applications, such as tanks and vessels, exhaust ducts and stacks or other equipment with need for basic thermal and/or acoustic insulation at standard process temperatures								EN 14303
<b>Material</b>	-	-	ULTIMATE mineral wool flexible board With quality marks EUCEB and RAL by the Gütegemeinschaft Mineralwolle e. V., unrisky regarding health according to German decree on dangerous substances, decree on prohibition of chemicals and to regulation EC No 1272/2008 Note Q								CINI 2.1.01
<b>Facing</b>	-	-	On request: Reinforced aluminium facing (Alu1) Yellow or black glass veil facing (V1/V2) Black glass fabric facing (G1)								-
<b>Quality management</b>	-	-	CE-marked according to EN 14303 ISOVER is certified according to EN ISO 9001 and EN ISO 14001								EN 14303 EN ISO 9001 EN ISO 14001
<b>Miscellaneous</b>	-	-	Insulating material identification number: 10.07.01.10.02 For "Si" version, MW-EN 14303-T2-ST(+/100)360-WS1-AF11 For "G1" version, MW-EN 14303-T2-ST(+/100)360-CL10- AF11 For "V1" version, MW-EN 14303-T4-ST(+/100)360-CL10- AF11 For "V2" version, MW-EN 14303-T2-ST(+/100)360- AF10 For "Alu1" version, MW-EN 14303-T4-ST(+/100)360-CL10								AGI Q 132 EN 14303

\* These values proceed from tests conducted in laboratory under certain given conditions. Real life conditions may differ due to various ambient and operational factors. These values are therefore representative and should only be used as a guide for estimation purposes. ISOVER takes no responsibility in the case of not achieving the required acoustical performance.

Delivery form: Standard dimensions / packaging information*					
Thickness d [mm]	Width b [mm]	Length l [mm]	m <sup>2</sup> /pack	m <sup>2</sup> /pallet	Packs/pallet
100	600	1,250	3.75	60	16

\* all dimensions require minimum order quantities / other dimensions on request



# U TECH Slab MT 3.0 Alu1/V1/V2

## The ULTIMATE solution for light and flexible insulation slabs

ULTIMATE U TECH Slab MT 3.0 is the flexible and light alternative to standard industry slabs. The ULTIMATE slab is designed for combining standard thermal and acoustic insulation with light weight and flexibility for surface temperatures of up to 400 °C – making the installation fast, efficient and as easy as possible. U TECH Slab 3.0 is produced in AS-Quality (Cl- ≤ 10 ppm) for usage when in contact with austenitic steel structures. On request with yellow (V1) or black glass veil facing (V2) and reinforced aluminium facing (Alu1)



### Thermal insulation

Standard thermal performance for service temperatures up to 400 °C with up to 35 % better efficiency than standard solutions



### Fast installation

Flexibility, lightweight and compressibility helps to handle and install the product easier and faster



### Improved logistics

Transport and storage savings with up to 80 % more material per pallet than standard solutions



### Fire reaction

Non-combustible, Euroclass A1 for effective fire protection on industry sites



### Sound absorption

Up to 95 % of sound energy absorbed due to optimal longitudinal air flow resistance and uniform porosity values



### Lightweight

Lightweight solution with up to 50 % weight savings compared to standard insulation solutions



### Thermal Efficiency Indicator

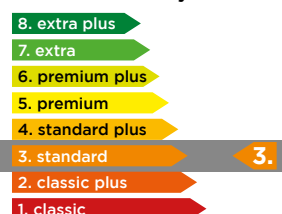



## The ULTIMATE solution for light and flexible insulation slabs

Characteristic	Symbol	Unit	Quantities and declared values							Standard
Thermal behaviour Max. service temp.	T	[°C]	400 (under 100 Pa)							EN 14706
			650							ASTM C411
Thermal conductivity	T	[°C]	10	50	100	150	200	300	400	EN 12667
		[W/(m•K)]	0.032	0.037	0.045	0.055	0.069	0.104	0.153	ISO 13787
Specific thermal capacity	c	[kJ/(kg•K)]	1.03							ISO 10456
Fire protection / Behaviour in fire	-	-	Non combustible; Euroclass A1							EN 13501-1
			Fire Spread Index = 0; Smoke Development Index < 20 Fire Spread Index ≤ 25; Smoke Development Index ≤ 25 for U TECH Slab MT 3.0 Alu1							ASTM E84
Chemical behaviour	-	-	AS-Quality Leachable chloride content less than 10 ppm (CL10) Do not contribute to corrosion of stainless steel							AGI Q 132 EN 13468 ASTM C795
Application field	-	-	Product for use in technical applications, such as tanks and vessels, exhaust ducts and stacks or other equipment with need for good thermal and/or acoustic insulation at medium process temperatures							EN 14303
Material	-	-	ULTIMATE mineral wool flexible board With quality marks EUCEB and RAL by the Gütegemeinschaft Mineralwolle e. V., unrisky regarding health according to German decree on dangerous substances, decree on prohibition of chemicals and to regulation EC No 1272/2008 Note Q							CINI 2.1.01
Facing	-	-	On request: Reinforced aluminium facing (Alu1) Yellow or black glass veil facing (V1/V2)							-
Quality management	-	-	CE-marked according to EN 14303 ISOVER is certified according to EN ISO 9001 and EN ISO 14001							EN 14303 EN ISO 9001 EN ISO 14001
Miscellaneous	-	-	Insulating material identification number: 10.07.02.20.03 For "Alu1" version, MW-EN 14303-T4-ST(+/100)400-CL10-MV2 For other versions, MW-EN 14303-T4-ST(+/100)400-CL10- AF20							AGI Q 132 EN 14303

Delivery form: Standard dimensions / packaging information*					
Thickness d [mm]	30	40	50	60	100
Width b [mm]	600	600	600	600	600
Length l [mm]	1,200	1,200	1,200	1,200	1,200
m <sup>2</sup> /pack	9.36	7.20	5.76	4.32	2.88
m <sup>2</sup> /pallet	112.32	86.40	69.12	51.84	34.56
Slabs/pack	13	10	8	6	4
Packs/pallet	12	12	12	12	12

\* all dimensions require minimum order quantities / other dimensions on request



# U TECH Slab MT 3.1 Alu1/V1/V2

## The ULTIMATE solution for light and flexible insulation slabs

ULTIMATE U TECH Slab MT 3.1 is the light alternative to standard industry slabs. The ULTIMATE slab is designed for combining standard thermal and acoustic insulation with light weight for surface temperatures of up to 400 °C - making the installation fast, efficient and as easy as possible. Compared to U TECH Slab MT 3.0, the version 3.1 has improved rigidity and is less flexible. U TECH Slab 3.1 for usage when in contact with austenitic steel structures. On request with black (V1) or yellow glass veil facing (V2) and reinforced aluminium facing (Alu1).



### Thermal insulation

Standard thermal performance for service temperatures up to 400 °C with up to 35 % better efficiency than standard solutions



### Fast installation

Flexibility, lightweight and compressibility helps to handle and install the product easier and faster



### Improved logistics

Transport and storage savings with up to 80 % more material per pallet than standard solutions



### Fire reaction

Non-combustible, Euroclass A1 for effective fire protection on industry sites



### Sound absorption

Up to 95 % of sound energy absorbed due to optimal longitudinal air flow resistance and uniform porosity values



### Lightweight

Lightweight solution with up to 50 % weight savings compared to standard insulation solutions



### Thermal Efficiency Indicator

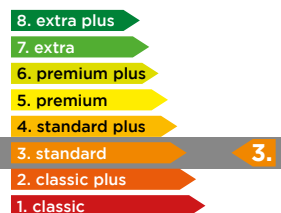



## The ULTIMATE solution for light and flexible insulation slabs

Characteristic	Symbol	Unit	Quantities and declared values								Standard
Thermal behaviour Max. service temp.	T	[°C]	400 (under 100 Pa)								EN 14706
			650								ASTM C411
Thermal conductivity	T	[°C]	10	50	100	150	200	300	400	EN 12667	
		[W/(m•K)]	0.032	0.037	0.045	0.055	0.069	0.104	0.153	ISO 13787	
Specific thermal capacity	c	[kJ/(kg•K)]	1.03								ISO 10456
Sound absorption*	p	Hz	w	125	250	500	1,000	2,000	4,000	Thickness [mm]	EN ISO 11654 EN ISO 354
		-	1.00	0.18	0.82	1.09	1.07	1.02	1.09	50	
		-	1.00	0.70	1.15	1.09	1.09	1.05	1.11	100	
Airflow resistivity*	AFR	kPa-s/m	> 20								ISO 9053-1
Fire protection / Behaviour in fire	-	-	Non combustible; Euroclass A1								EN 13501-1
			Fire Spread Index = 0; Smoke Development Index < 20 Fire Spread Index ≤ 25; Smoke Development Index ≤ 25 for U TECH Slab MT 3.1 Alu1								ASTM E84
Chemical behaviour	-	-	AS-Quality Do not contribute to corrosion of stainless steel								AGI Q 132 ASTM C795
Application field	-	-	Product for use in technical applications, such as tanks and vessels, exhaust ducts and stacks or other equipment with need for good thermal and/or acoustic insulation at medium process temperatures								EN 14303
Material	-	-	ULTIMATE mineral wool flexible board With quality marks EUCEB, unrisky regarding health according to regulation EC No 1272/2008 Note Q								CINI 2.1.01
Facing	-	-	On request: Reinforced aluminium facing (Alu1) Yellow or black glass veil facing (V1/V2)								-
Quality management	-	-	CE-marked according to EN 14303 ISOVER is certified according to EN ISO 9001 and EN ISO 14001								EN 14303 EN ISO 9001 EN ISO 14001
Miscellaneous	-	-	Insulating material identification number: 10.07.02.20.03 For "Alu1" version, MW-EN 14303-T4-ST(+/100)400-MV2 For other versions, MW-EN 14303-T4-ST(+/100)400-AF20								AGI Q 132 EN 14303

\* These values proceed from tests conducted in laboratory under certain given conditions. Real life conditions may differ due to various ambient and operational factors. These values are therefore representative and should only be used as a guide for estimation purposes. ISOVER takes no responsibility in the case of not achieving the required acoustical performance.

Delivery form: Standard dimensions / packaging information*						
Thickness d [mm]	30	40	50	60	80	100
Width b [mm]	600	600	600	600	600	600
Length l [mm]	1,250	1,250	1,250	1,250	1,250	1,250
m <sup>2</sup> /pack	10.50	7.50	6.00	4.50	3.75	3.00
m <sup>2</sup> /pallet	126	90	72	54	45	36
Packs/pallet	12	12	12	12	12	12

\* all dimensions require minimum order quantities / other dimensions on request



# U TECH Slab MT 5.0 Alu1/V1/V2

## The **ULTIMATE** solution for premium performance and light industry slabs in medium-high temperatures

ULTIMATE U TECH Slab MT 5.0 is the efficient but still light alternative to heavy-dense industry slabs. The ULTIMATE slab is designed for combining premium thermal and acoustic insulation with reduced weight at surface temperatures of up to 540 °C. Continuously performing even under tough conditions e.g. mechanical stress like vibrations makes U TECH Slab MT 5.0 the economic choice in medium to high temperatures. U TECH Slab MT 5.0 is produced in AS-Quality (Cl- ≤ 10 ppm) for usage when in contact with austenitic steel structures. On request with yellow (V1) or black glass veil (V2) and reinforced aluminium facing (Alu1).



### Energy efficiency

Premium thermal performance for service temperatures up to 540 °C with up to 35 % better efficiency



### Fast installation

Flexibility, lightweight and compressibility helps to handle and install the product easier and faster



### Cost effective solution

Premium thermal performance combined with lightweight provides installation time saving and less heat loss costs



### Improved logistics

Transport and storage savings with up to 80 % more material per pallet than standard solutions



### Fire reaction

Non-combustible, Euroclass A1 for effective fire protection on industry sites



### Sound insulation

The ability of mineral wool to act as a spring results in reducing vibration and noise emissions in industrial processes



### Thermal Efficiency Indicator

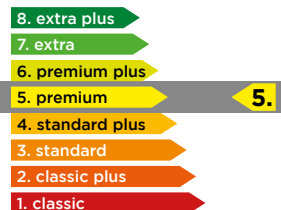



## The ULTIMATE solution for premium performance and light industry slabs

Characteristic	Symbol	Unit	Quantities and declared values								Standard
Thermal behaviour Max. service temp.	T	[°C]	540 (under 500 Pa)								EN 14706
			700								ASTM C411
Thermal conductivity	T	[°C]	10	50	100	150	200	300	400	500	EN 12667 ISO 13787
		[W/(m•K)]	0.031	0.036	0.041	0.049	0.057	0.078	0.104	0.138	
Specific thermal capacity	c	[kJ/(kg•K)]	1.03								ISO 10456
Fire protection / Behaviour in fire	-	-	Non combustible; Euroclass A1								EN 13501-1
			Fire Spread Index = 0; Smoke Development Index < 20 Fire Spread Index ≤ 25; Smoke Development Index ≤ 25 for U TECH Slab MT 5.0 Alu1								ASTM E84
Chemical behaviour	-	-	AS-Quality Leachable chloride content less than 10 ppm (CL10) Do not contribute to corrosion of stainless steel								AGI Q 132 EN 13468 ASTM C795
Application field	-	-	Product for use in technical applications, such as tanks and vessels, exhaust ducts and stacks or other equipment with need for very good thermal and/or acoustic insulation at high process temperatures								EN 14303
Material	-	-	ULTIMATE mineral wool board With quality marks EUCEB and RAL by the Gütegemeinschaft Mineralwolle e. V., unriskey regarding health according to German decree on dangerous substances, decree on prohibition of chemicals and to regulation EC No 1272/2008 Note Q								CINI 2.1.01
Facing	-	-	On request: Reinforced aluminium facing (Alu1) Yellow or black glass veil facing (V1/V2)								-
Quality management	-	-	CE-marked according to EN 14303 ISOVER is certified according to EN ISO 9001 and EN ISO 14001								EN 14303 EN ISO 9001 EN ISO 14001
Miscellaneous	-	-	Insulation material designation code: 10.07.02.20.05 For "Alu1" version, MW-EN 14303-T4-ST(+)-540-CL10-MV2 For other versions, MW-EN 14303-T4-ST(+)-540-CL10-AF40								AGI Q 132 EN 14303

Delivery form: Standard dimensions / packaging information*						
Thickness d [mm]	30	40	50	60	100	
Width b [mm]	600	600	600	600	600	
Length l [mm]	1,200	1,200	1,200	1,200	1,200	
m <sup>2</sup> /pack	9.36	7.20	5.76	4.32	2.88	
m <sup>2</sup> /pallet	112.32	86.40	69.12	51.84	34.56	
Slabs/pack	13	10	8	6	4	
Packs/pallet	12	12	12	12	12	

\* all dimensions require minimum order quantities / other dimensions on request



# U TECH Slab MT 6.0 Alu1/V1/G1

## The **ULTIMATE** solution for premium-plus performance and efficient industry slabs in medium-high temperatures

ULTIMATE U TECH Slab MT 6.0 is the efficient and sustainable alternative to heavy-dense industry slabs. The ULTIMATE slab is designed for premium-plus thermal and acoustic insulation performance, reduced weight for temperatures of up to 620 °C. Continuously performing even under tough conditions e.g. mechanical stress like vibrations ensuring lifetime performance and savings of energy costs through reduced heat loss makes U TECH Slab MT 6.0 the sustainable choice. U TECH Slab MT 6.0 is produced in AS-Quality (Cl- ≤ 10 ppm) for usage when in contact with austenitic steel structures. On request with yellow glass veil facing (V1) or black glass fabric (G1) and reinforced aluminium facing (Alu1).



### Energy efficiency

Premium-Plus thermal performance for service temperatures up to 620 °C with up to 35 % better efficiency



### High service temperatures

Especially designed for high service temperatures up to 620 °C



### Thin solution

Personal protection and heat loss requirements achieved with up to 35 % less insulation thickness than standard solutions



### Lightweight

Lightweight solution with up to 50 % weight savings compared to standard insulation solutions



### Sound insulation

The ability of mineral wool to act as a spring results in reducing vibration and noise emissions in industrial processes



### Fire reaction

Non-combustible, Euroclass A1 for effective fire protection on industry sites



### Thermal Efficiency Indicator

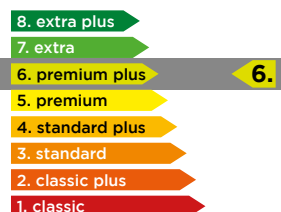



## The ULTIMATE solution for premium-plus performance industry slabs

Characteristic	Symbol	Unit	Quantities and declared values	Standard
<b>Thermal behaviour Max. service temp.</b>	T	[°C]	620 (under 500 Pa)	EN 14706
			700	ASTM C411
<b>Thermal conductivity</b>	T	[°C]	10 50 100 150 200 300 400 500 600	EN 12667
		[W/(m•K)]	0.031 0.035 0.040 0.047 0.054 0.072 0.096 0.120 0.162	ISO 13787
<b>Specific thermal capacity</b>	c	[kJ/(kg•K)]	1.03	ISO 10456
<b>Fire protection / Behaviour in fire</b>	-	-	Non combustible; Euroclass A1 Euroclass A2-s1, d0 for U TECH Slab MT 6.0 G1	EN 13501-1
			Fire Spread Index = 0; Smoke Development Index < 20 Fire Spread Index ≤ 25; Smoke Development Index ≤ 25 for U TECH Slab MT 6.0 Alu1	ASTM E84
<b>Chemical behaviour</b>	-	-	AS-Quality Leachable chloride content less than 10 ppm (CL10) Do not contribute to corrosion of stainless steel	AGI Q 132 EN 13468 ASTM C795
<b>Application field</b>	-	-	Product for use in technical applications, such as tanks and vessels, exhaust ducts and stacks or other equipment with need for excellent thermal and/or acoustic insulation at high process temperatures	EN 14303
<b>Material</b>	-	-	ULTIMATE mineral wool board With quality marks EUCEB and RAL by the Gütegemeinschaft Mineralwolle e. V., unrisky regarding health according to German decree on dangerous substances, decree on prohibition of chemicals and to regulation EC No1272/2008 Note Q	CINI 2.1.01
<b>Facing</b>	-	-	On request: Reinforced aluminium facing (Alu1) Yellow glass veil facing (V1) Black glass fabric facing (G1)	-
<b>Quality management</b>	-	-	CE-marked according to EN 14303 ISOVER is certified according to EN ISO 9001 and EN ISO 14001	EN 14303 EN ISO 9001 EN ISO 14001
<b>Miscellaneous</b>	-	-	Insulating material identification number: 10.07.05.20.06 For "Alu1" version, MW-EN 14303-T4-ST(+)-620-CL10-MV2 For other versions, MW-EN 14303-T4-ST(+)-620-CL10-AF50	AGI Q 132 EN 14303

Delivery form: Standard dimensions / packaging information*					
<b>Thickness d [mm]</b>	30	40	50	60	100
<b>Width b [mm]</b>	600	600	600	600	600
<b>Length l [mm]</b>	1,200	1,200	1,200	1,200	1,200
<b>m<sup>2</sup>/pack</b>	9.36	7.20	5.76	3.60	2.88
<b>m<sup>2</sup>/pallet</b>	112.32	86.40	69.12	43.20	34.56
<b>Slabs/pack</b>	13	10	8	5	4
<b>Packs/pallet</b>	12	12	12	12	12

\* all dimensions require minimum order quantities / other dimensions on request



# TECH Telisol 5.0 QN

## Nuclear-quality-designed special white glass mineral wool blanked stitched on stainless wire mesh

TECH Telisol 5.0 QN is the premium thermal insulation solution designed to meet the tough requirements of the nuclear power industry. It can be used for insulation of the heat exchanger and steam pipes. TECH Telisol 5.0 QN provides premium thermal insulation and keeps its performance long-term even when exposed to mechanical stress due to an elastic fiber structure. TECH Telisol is almost free of organic content, does not contain corrosion-supportive ions and is stitched with a yarn on austenitic stainless wire mesh to allow flexible bending. When upheated, the product can expand and fill possible gaps and joints.



### Nuclear plant quality

Especially designed and certified for use in nuclear applications



### Energy efficiency

Premium thermal insulation performance at medium to higher service temperatures up to 350 °C



### Fast installation

Flexibility, lightweight and compressibility helps to handle and install the product easier and faster



### Fire reaction

Non-combustible, Euroclass A1 for effective fire protection on industry sites



### High flexibility

Highly-flexible with almost no binder or other organic, keeping elasticity over full operational life-time



### Environmental protection

Its Premium thermal performance allows to reduce significantly energy losses, the use of natural resources and CO<sub>2</sub> emissions



### Thermal Efficiency Indicator

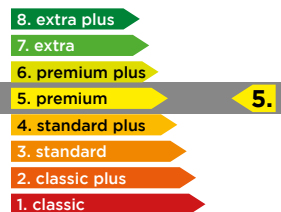



## Nuclear-quality-designed special white glass mineral wool blanked stitched on stainless wire mesh

Characteristic	Symbol	Unit	Quantities and declared values	Standard				
<b>Thermal behaviour</b>	T	[°C]	350 (under 500 Pa)	EN 14706				
<b>Thermal conductivity</b>	T	[°C]	50	100	150	200	300	EN 12667 ISO 13787
		[W/(m•K)]	0.038	0.045	0.052	0.062	0.083	
<b>Fire protection / Behaviour in fire</b>	-	-	Non combustible; Euroclass A1					EN 13501-1
			Fire Spread Index = 0; Smoke Development Index < 20					ASTM E84
<b>Chemical behaviour</b>	-	-	AS-Quality Do not contribute to corrosion of stainless steel					AGI Q 132 ASTM C795
<b>Application field</b>	-	-	Product for use in technical applications, such as tanks and vessels, boilers and process equipment. Especially designed and certified for use in nuclear applications (PMUC 09-0002)					EN 14303 PMUC 09-0002
<b>Material</b>	-	-	Glass mineral wool surfaced with a stainless steel hexagonal mesh without binder With quality marks EUCEB and RAL by the Gütegemeinschaft Mineralwolle e. V., unrisky regarding health according to German decree on dangerous substances, decree on prohibition of chemicals and to regulation EC No 1272/2008 Note Q					CINI 2.1.02
<b>Facing</b>			-					-
<b>Quality management</b>	-	-	CE-marked according to EN 14303 ISOVER is certified according to EN ISO 9001 and EN ISO 14001					EN 14303 EN ISO 9001 EN ISO 14001
<b>Miscellaneous</b>	-	-	MW-EN-14303-T2-ST(+)-350 Storage: Bags to be stored indoors in a dry and clean place away from source of humidity					EN 14303

Delivery form: Standard dimensions / packaging information*				
<b>Thickness d [mm]</b>	50	60	80	100
<b>Length l [mm]</b>	5,000	4,000	3,000	3,000
<b>Width b [mm]</b>	1,000	1,000	1,000	1,000
<b>Unit/pack</b>	1 roll	1 roll	1 roll	1 roll
<b>m<sup>2</sup>/pack</b>	5.00	4.00	3.00	3.00

\* all dimensions require minimum order quantities / other dimensions on request



# TECH Wired Mat MT 3.0 Alu1/X/X-X

## Standard performance cost effective stone mineral wool mats

TECH Wired Mat MT 3.0 is the medium-weight stone mineral wool mat stitched with galvanized wire on hexagonal galvanized wire mesh for flexible installation on uneven structures such as big diameter pipes, tanks and vessels, exhaust ducts and stacks with a maximum service temperature of up to 550 °C. TECH Wired Mat MT 3.0 is available in AS Quality (CL- ≤ 10 ppm) when in contact with austenitic steel structures. On request with stainless steel wire (X) or stainless steel wire and wire mesh (X-X) and reinforced aluminium facing (Alu1).



### Thermal insulation

Standard thermal insulation performance for service temperatures up to 550 °C



### Fast installation

Flexibility, lightweight and compressibility helps to handle and install the product easier and faster



### Fire reaction

Non-combustible, Euroclass A1 for effective fire protection on industry sites



### Nuclear plant quality

Certified for use in nuclear applications



### High service temperatures

Especially designed for high service temperatures up to 550 °C



### Sound absorption

Up to 95 % of sound energy absorbed due to optimal longitudinal air flow resistance and uniform porosity values



### Thermal Efficiency Indicator

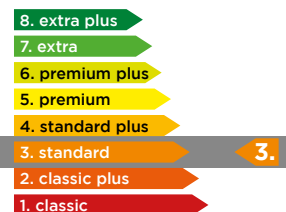



## Standard performance cost effective stone mineral wool mats

Characteristic	Symbol	Unit	Quantities and declared values							Standard
Thermal behaviour Max. service temp.	T	[°C]	550 (under 500 Pa)							EN 14706
			650							ASTM C411
Thermal conductivity	T	[°C]	50	100	150	200	300	400	500	EN 12667 ISO 13787
		[W/(m•K)]	0.041	0.048	0.056	0.067	0.097	0.134	0.183	
Specific thermal capacity	c	[kJ/(kg•K)]	1.03							ISO 10456
Fire protection / Behaviour in fire	-	-	Non combustible; Euroclass A1							EN 13501-1
			Fire Spread Index = 0; Smoke Development Index < 20							ASTM E84
Chemical behaviour	-	-	AS-Quality Leachable chloride content less than 10 ppm (CL10) Do not contribute to corrosion of stainless steel No short term water absorption by partial immersion (WS1)							AGI Q 132 EN 13468 ASTM C795 EN 1609
Application field	-	-	Product for use in technical applications, such as big diameter pipes, tanks and vessels, exhaust ducts and stacks, and process equipment Certified for use in nuclear applications (PMUC 09-0010)							EN 14303 PMUC 09-0010
Material	-	-	Stone mineral wool, stitched on metallic mesh with either galvanized or austenitic stainless steel wire With quality marks EUCEB and RAL by the Gütegemeinschaft Mineralwolle e. V., unrisky regarding health according to German decree on dangerous substances, decree on prohibition of chemicals and to regulation EC No 1272/2008 Note Q							CINI 2.2.02
Facing	-	-	On request: Reinforced aluminium facing (Alu1)							-
Quality management	-	-	CE-marked according to EN 14303 ISOVER is certified according to EN ISO 9001 and EN ISO 14001							EN 14303 EN ISO 9001 EN ISO 14001
Miscellaneous	-	-	Insulating material identification number: 10.01.01.99.07 MW-EN 14303-T2-ST(+)-550-WS1-CL10							AGI Q 132 EN 14303

Delivery form: Standard dimensions / packaging information*									
Thickness** d (mm)	30	40	50	60	70	80	90	100	120
Width b (mm)	600	600	600	600	600	600	600	600	600
Length l (mm)	8,000	6,000	5,000	5,000	4,000	3,500	3,000	3,000	2,500
m <sup>2</sup> /roll	4.8	3.6	3.0	3.0	2.4	2.1	1.8	1.8	1.5
m <sup>2</sup> /pallet	172.80	129.60	108.00	96.00	86.40	75.60	64.80	57.60	48.00
rolls/pallet	36	36	36	32	36	36	36	32	32

\* all dimensions require minimum order quantities / other dimensions on request

\*\* Under a load of 1000 Pa



# TECH Wired Mat MT 3.1 Alu1/X/X-X

## Standard performance cost-effective stone mineral wool mats

TECH Wired Mat MT 3.1 is the medium-weight stone mineral wool mat stitched with galvanized wire on hexagonal galvanized wire mesh for flexible installation on uneven structures such as big diameter pipes, tanks and vessels, exhaust ducts and stacks with a maximum service temperature of up to 560 °C. TECH Wired Mat MT 3.1 is available in AS Quality (CL- ≤ 10 ppm) when in contact with austenitic steel structures. On request with stainless steel wire (X) or stainless steel wire and wire mesh (X-X) and reinforced aluminium facing (Alu1).



### Thermal insulation

Standard thermal insulation performance for service temperatures up to 560 °C



### Fast installation

Flexibility, lightweight and compressibility helps to handle and install the product easier and faster



### Fire reaction

Non-combustible, Euroclass A1 for effective fire protection on industry sites



### Sound absorption

Up to 95 % of sound energy absorbed due to optimal longitudinal air flow resistance and uniform porosity values



### High service temperatures

Especially designed for high service temperatures up to 560 °C



### High flexibility

Highly-flexible wired mats, keeping elasticity over full operational life-time



### Thermal Efficiency Indicator

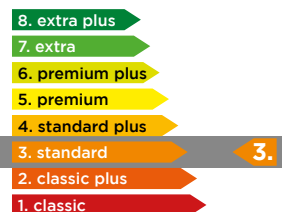



## Standard performance cost-effective stone mineral wool mats

Characteristic	Symbol	Unit	Quantities and declared values								Standard
<b>Thermal behaviour Max. service temp.</b>	T	[°C]	560 (under 500 Pa)								EN 14706
			700								ASTM C411
<b>Thermal conductivity</b>	T	[°C]	50	100	150	200	300	400	500	550	EN 12667 ISO 13787
		[W/(m•K)]	0.040	0.047	0.057	0.067	0.094	0.130	0.173	0.185	
<b>Specific thermal capacity</b>	c	[kJ/(kg•K)]	1.03								ISO 10456
<b>Sound absorption*</b>	p	Hz	w	125	250	500	1,000	2,000	4,000	Thickness [mm]	EN ISO 11654 EN ISO 354
		-	1.00	0.34	0.95	1.16	1.11	1.10	1.12	50	
		-	1.00	0.89	0.98	1.02	1.08	1.06	1.08	100	
<b>Airflow resistivity*</b>	AFR	kPa-s/m	> 25								ISO 9053-1
<b>Fire protection / Behaviour in fire</b>	-	-	Non combustible; Euroclass A1								EN 13501-1
			Fire Spread Index = 0; Smoke Development Index < 20								ASTM E84
<b>Chemical behaviour</b>	-	-	AS-Quality (CL10 according EN 13468 measurement) on request Do not contribute to corrosion of stainless steel No short term water absorption by partial immersion (WS1)								AGI Q 132 EN 13468 ASTM C795 EN 1609
<b>Application field</b>	-	-	Product for use in technical applications, such as big diameter pipes, tanks and vessels, exhaust ducts and stacks, and process equipment								EN 14303
<b>Material</b>	-	-	Stone mineral wool, stitched on metallic mesh with either galvanized or austenitic stainless steel wire With quality marks EUCEB, unrisky regarding health according to regulation EC No 1272/2008 Note Q								CINI 2.2.02
<b>Facing</b>	-	-	On request: Reinforced aluminium facing (Alu1)								-
<b>Quality management</b>	-	-	CE-marked according to EN 14303 ISOVER is certified according to EN ISO 9001 and EN ISO 14001								EN 14303 EN ISO 9001 EN ISO 14001
<b>Miscellaneous</b>	-	-	MW-EN 14303-T2-ST(+)-560-WS1								EN 14303
<b>Delivery form</b>	-	-	Please contact your local ISOVER dealer All dimensions require minimum order quantities Standard width: 500 mm 600 mm 1,000 mm Standard thickness range: 30 mm until 120 mm Other dimensions on request								-

\* These values proceed from tests conducted in laboratory under certain given conditions. Real life conditions may differ due to various ambient and operational factors. These values are therefore representative and should only be used as a guide for estimation purposes. ISOVER takes no responsibility in the case of not achieving the required acoustical performance.



# TECH Wired Mat MT 4.0 Alu1/X/X-X

## Standard-Plus performance flexible stone mineral wool wired mats

TECH Wired Mat MT 4.0 is the standard-weight stone mineral wool mat stitched with galvanized wire on hexagonal galvanized wire mesh for flexible installation on uneven structures such as big diameter pipes, tanks and vessels, exhaust ducts and stacks with a maximum service temperature of up to 600 °C. TECH Wired Mat MT 4.0 is produced in AS Quality (CL- ≤10 ppm) for usage when in contact with austenitic steel structures. On request with stainless steel wire (X) or stainless steel wire and wire mesh (X-X) and reinforced aluminium facing (Alu1).



### Thermal insulation

Standard-Plus thermal insulation performance for service temperatures up to 600 °C



### High service temperatures

Especially designed for high service temperatures up to 600 °C



### Sound insulation

The ability of mineral wool to act as a spring results in reducing vibration and noise emissions in industrial processes



### Fire reaction

Non-combustible, Euroclass A1 for effective fire protection on industry sites



### Thermal Efficiency Indicator

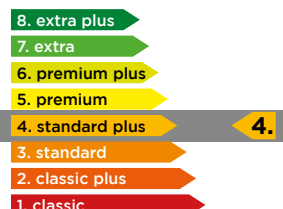



## Standard-Plus performance flexible stone mineral wool wired mats

Characteristic	Symbol	Unit	Quantities and declared values								Standard
<b>Thermal behaviour</b> Max. service temp.	T	[°C]	600 (under 500 Pa)								EN 14706
			650								ASTM C411
<b>Thermal conductivity</b>	T	[°C]	50	100	150	200	300	400	500	600	EN 12667 ISO 13787
		[W/(m•K)]	0.040	0.047	0.055	0.065	0.090	0.124	0.167	0.217	
<b>Specific thermal capacity</b>	c	[kJ/(kg•K)]	1.03								ISO 10456
<b>Fire protection / Behaviour in fire</b>	-	-	Non combustible; Euroclass A1								EN 13501-1
			Fire Spread Index = 0; Smoke Development Index < 20								ASTM E84
<b>Chemical behaviour</b>	-	-	AS-Quality Leachable chloride content less than 10 ppm (CL10) Do not contribute to corrosion of stainless steel No short term water absorption by partial immersion (WS1)								AGI Q 132 EN 13468 ASTM C795 EN 1609
<b>Application field</b>	-	-	Product for use in technical applications, such as big diameter pipes, tanks and vessels, boilers, exhaust ducts and stacks								EN 14303
<b>Material</b>	-	-	Stone mineral wool, stitched on metallic mesh with either galvanized or austenitic stainless steel wire With quality marks EUCEB and RAL by the Gütegemeinschaft Mineralwolle e. V., unrisky regarding health according to German decree on dangerous substances, decree on prohibition of chemicals and to regulation EC No 1272/2008 Note Q								CINI 2.2.02
<b>Facing</b>	-	-	On request: Reinforced aluminium facing (Alu1)								-
<b>Quality management</b>	-	-	CE-marked according to EN 14303 Quality control according to VDI 2055 ISOVER is certified according to EN ISO 9001 and EN ISO 14001								EN 14303 VDI 2055 EN ISO 9001 EN ISO 14001
<b>Miscellaneous</b>	-	-	Insulating material identification number: 10.01.02.30.08 MW-EN 14303-T2-ST(+)-600-WS1-CL10								AGI Q 132 EN 14303

Delivery form: Standard dimensions / packaging information*									
<b>Thickness** d (mm)</b>	30	40	50	60	70	80	90	100	120
<b>Width b (mm)</b>	500	500	500	500	500	500	500	500	500
<b>Length l (mm)</b>	8,000	8,000	5,000	5,000	5,000	4,000	4,000	4,000	4,000
<b>m<sup>2</sup>/roll</b>	4.0	4.0	2.5	2.5	2.5	2.0	2.0	2.0	2.0
<b>m<sup>2</sup>/pallet</b>	180.0	160.0	112.5	100.0	100.0	80.0	60.0	60.0	40.0
<b>rolls/pallet</b>	45	40	45	40	40	40	30	30	20

\* all dimensions require minimum order quantities / other dimensions on request

\*\* Under a load of 1000 Pa



# TECH Wired Mat MT 4.1 Alu1/X/X-X

## Standard-Plus performance flexible stone mineral wool wired mats

TECH Wired Mat MT 4.1 is the standard-weight stone mineral wool mat stitched with galvanized wire on hexagonal galvanized wire mesh for flexible installation on uneven structures such as big diameter pipes, tanks and vessels, boilers, exhaust ducts and stacks with a maximum service temperature of up to 640 °C. TECH Wired Mat MT 4.1 is available in AS Quality (CL- ≤10 ppm) when in contact with austenitic steel structures. On request available with stainless steel wire (X) or stainless steel wire and wire mesh (X-X) and reinforced aluminium facing (Alu1).



### High service temperatures

Especially designed for high service temperatures up to 640 °C



### Thermal insulation

Standard-Plus thermal insulation performance for service temperatures up to 640 °C



### Sound insulation

The ability of mineral wool to act as a spring results in reducing vibration and noise emissions in industrial processes



### Fire reaction

Non-combustible, Euroclass A1 for effective fire protection on industry sites



### Thermal Efficiency Indicator

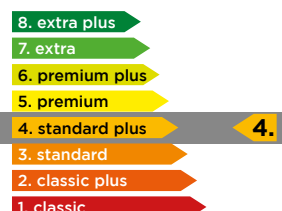



## Standard-Plus performance flexible stone mineral wool wired mats

Characteristic	Symbol	Unit	Quantities and declared values								Standard
<b>Thermal behaviour Max. service temp.</b>	T	[°C]	640 (under 500 Pa)								EN 14706
			700								ASTM C411
<b>Thermal conductivity</b>	T	[°C]	50	100	200	300	400	500	600	EN 12667	
		[W/(m•K)]	0.039	0.045	0.062	0.084	0.112	0.146	0.192	ISO 13787	
<b>Specific thermal capacity</b>	c	[kJ/(kg•K)]	1.03								ISO 10456
<b>Sound absorption*</b>	ρ	Hz	w	125	250	500	1,000	2,000	4,000	Thickness [mm]	EN ISO 11654 EN ISO 354
		-	1.00	0.28	0.93	1.09	1.07	1.08	1.08	50	
		-	1.00	0.72	1.07	1.03	1.11	1.06	1.09	100	
<b>Airflow resistivity*</b>	AFR	kPa-s/m	> 25								ISO 9053-1
<b>Fire protection / Behaviour in fire</b>	-	-	Non combustible; Euroclass A1								EN 13501-1
			Fire Spread Index = 0; Smoke Development Index < 20								ASTM E84
<b>Chemical behaviour</b>	-	-	AS-Quality (CL10 according EN 13468 measurement) on request Do not contribute to corrosion of stainless steel No short term water absorption by partial immersion (WS1)								AGI Q 132 EN 13468 ASTM C795 EN 1609
<b>Application field</b>	-	-	Product for use in technical applications, such as big diameter pipes, tanks and vessels, boilers, exhaust ducts and stacks								EN 14303
<b>Material</b>	-	-	Stone mineral wool, stitched on metallic mesh with either galvanized or austenitic stainless steel wire With quality marks EUCEB, unrisky regarding health according to regulation EC No 1272/2008 Note Q								CINI 2.2.02
<b>Facing</b>	-	-	On request: Reinforced aluminium facing (Alu1)								-
<b>Quality management</b>	-	-	CE-marked according to EN 14303 ISOVER is certified according to EN ISO 9001 and EN ISO 14001								EN 14303 EN ISO 9001 EN ISO 14001
<b>Miscellaneous</b>	-	-	MW-EN 14303-T2-ST(+)-640-WS1								EN 14303
<b>Delivery form</b>	-	-	Please contact your local ISOVER dealer All dimensions require minimum order quantities Standard width: 500 mm 600 mm 1,000 mm Standard thickness range: 30 mm until 120 mm Other dimensions on request								-

\* These values proceed from tests conducted in laboratory under certain given conditions. Real life conditions may differ due to various ambient and operational factors. These values are therefore representative and should only be used as a guide for estimation purposes. ISOVER takes no responsibility in the case of not achieving the required acoustical performance.



# TECH Wired Mat MT 4.2 x/x-x

## Standard-Plus performance flexible stone mineral wool wired mats

TECH Wired Mat MT 4.2 is the standard-weight stone mineral wool mat stitched with galvanized wire on hexagonal galvanized wire mesh for flexible installation on uneven structures such as big diameter pipes, tanks and vessels, boilers, exhaust ducts and stacks with a maximum service temperature of up to 600 °C. TECH Wired Mat MT 4.2 is available in AS Quality (CL- ≤ 10 ppm) when in contact with austenitic steel structures. On request available with stainless steel wire (X) or stainless steel wire and wire mesh (X-X).



### Thermal insulation

Standard-Plus thermal insulation performance for service temperatures up to 600 °C



### High service temperatures

Especially designed for high service temperatures up to 600 °C



### Sound insulation

The ability of mineral wool to act as a spring results in reducing vibration and noise emissions in industrial processes



### Fire reaction

Non-combustible, Euroclass A1 for effective fire protection on industry sites



### Thermal Efficiency Indicator

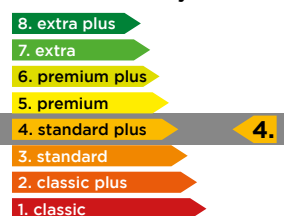



## Standard-Plus performance flexible stone mineral wool wired mats

Characteristic	Symbol	Unit	Quantities and declared values						Standard
Thermal behaviour	T	[°C]	600 (under 500 Pa)						EN 14706
			700						ASTM C411
Thermal conductivity	T	[°C]	50	200	300	400	500	600	EN 12667
		[W/(m•K)]	0.041	0.065	0.090	0.124	0.167	0.217	ISO 13787
Specific thermal capacity	c	[kJ/(kg•K)]	1.03						ISO 10456
Fire protection / Behaviour in fire	-	-	Non combustible; Euroclass A1						EN 13501-1
			Fire Spread Index = 0; Smoke Development Index < 20						ASTM E84
Chemical behaviour	-	-	AS-Quality Do not contribute to corrosion of stainless steel No short term water absorption by partial immersion (WS1)						AGI Q 132 ASTM C795 EN 1609
Application field	-	-	Product for use in technical applications, such as big diameter pipes, tanks and vessels, boilers, exhaust ducts and stacks						EN 14303
Material	-	-	Stone mineral wool, stitched on metallic mesh with either galvanized or austenitic stainless steel wire With quality marks EUCEB, unrisky regarding health according to regulation EC No 1272/2008 Note Q						CINI 2.2.02
Facing	-	-	-						-
Quality management	-	-	CE-marked according to EN 14303 ISOVER is certified according to EN ISO 9001 and EN ISO 14001						EN 14303 EN ISO 9001 EN ISO 14001
Miscellaneous	-	-	MW-EN 14303-T2-ST(+)-600-WS1						EN 14303

Delivery form: Standard dimensions / packaging information*							
Thickness d [mm]	40	50	60	70	80	100	120
Length l [mm]	6,000	5,000	5,000	4,500	3,000	3,000	2,500
Width b [mm]	1,000	1,000	1,000	1,000	1,000	1,000	1,000
m <sup>2</sup> /pack	6.00	5.00	5.00	4.50	3.00	3.00	2.50
m <sup>2</sup> /pallet	90.00	75.00	75.00	67.50	45.00	45.00	37.50
m <sup>2</sup> /truck	2,340	1,950	1,950	1,755	1,170	1,170	975

\* all dimensions require minimum order quantities / other dimensions on request



# TECH Wired Mat MT 5.0 Alu1/X/X-X

## Premium performance robust industry stone mineral wool wired mats for medium-high temperatures

TECH Wired Mat MT 5.0 is the premium thermal performance stone mineral wool mat stitched with galvanized wire on hexagonal galvanized wire mesh for flexible installation on uneven structures such as big diameter pipes, tanks and vessels, exhaust ducts and stacks with a maximum service temperature of up to 620 °C. TECH Wired Mat MT 5.0 is produced in AS Quality (CL- ≤ 10 ppm) for usage when in contact with austenitic steel structures. On request with stainless steel wire (X) or stainless steel wire and wire mesh (X-X) and reinforced aluminium facing (Alu1). On request available also in „EX“ quality almost without organic content for use in explosion risk areas when in contact with liquid oxygene such as in cold boxes, air separation units etc. in line with application standards as AGI Q 118 and specifications of industrial gas providers e.g. Linde, Air Liquide, Air Products.



### Energy efficiency

Premium thermal insulation performance at medium to higher service temperatures up to 620 °C



### High service temperatures

Especially designed for high service temperatures up to 620 °C



### Sound insulation

The ability of mineral wool to act as a spring results in reducing vibration and noise emissions in industrial processes



### Explosion risk solution

Especially designed for use in explosion risk areas when in contact with liquid oxygene



### Fire reaction

Non-combustible, Euroclass A1 for effective fire protection on industry sites



#### Thermal Efficiency Indicator

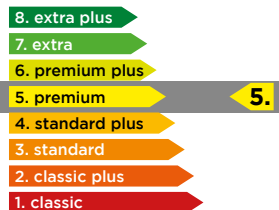



## Premium performance robust industry stone mineral wool wired mats

Characteristic	Symbol	Unit	Quantities and declared values								Standard
<b>Thermal behaviour</b> Max. service temp.	T	[°C]	620 (under 500 Pa)								EN 14706
			680								ASTM C411
<b>Thermal conductivity</b>	T	[°C]	50	100	150	200	300	400	500	600	EN 12667 ISO 13787
		[W/(m•K)]	0.040	0.046	0.052	0.061	0.083	0.110	0.145	0.190	
<b>Specific thermal capacity</b>	c	[kJ/(kg•K)]	1.03								ISO 10456
<b>Fire protection / Behaviour in fire</b>	-	-	Non combustible; Euroclass A1								EN 13501-1
			Fire Spread Index = 0; Smoke Development Index < 20								ASTM E84
<b>Chemical behaviour</b>	-	-	AS-Quality Leachable chloride content less than 10 ppm (CL10) Do not contribute to corrosion of stainless steel No short term water absorption by partial immersion (WS1)								AGI Q 132 EN 13468 ASTM C795 EN 1609
<b>Application field</b>	-	-	Product for use in technical applications, such as big diameter pipes, tanks and vessels, boilers, exhaust ducts and stacks								EN 14303
<b>Material</b>	-	-	Stone mineral wool, stitched on metallic mesh with either galvanized or austenitic stainless steel wire With quality marks EUCEB and RAL by the Gütegemeinschaft Mineralwolle e. V., unrisky regarding health according to German decree on dangerous substances, decree on prohibition of chemicals and to regulation EC No 1272/2008 Note Q								CINI 2.2.02
<b>Facing</b>	-	-	On request: Reinforced aluminium facing (Alu1)								-
<b>Quality management</b>	-	-	CE-marked according to EN 14303 Quality control according to VDI 2055 ISOVER is certified according to EN ISO 9001 and EN ISO 14001								EN 14303 VDI 2055 EN ISO 9001 EN ISO 14001
<b>Miscellaneous</b>	-	-	Insulating material identification number: 10.01.02.40.10 MW-EN 14303-T2-ST(+)-620-WS1-CL10								AGI Q 132 EN 14303

Delivery form: Standard dimensions / packaging information*									
<b>Thickness** d (mm)</b>	30	40	50	60	70	80	90	100	120
<b>Width b (mm)</b>	500	500	500	500	500	500	500	500	500
<b>Length l (mm)</b>	8,000	8,000	5,000	5,000	5,000	4,000	4,000	3,000	3,000
<b>m<sup>2</sup>/roll</b>	4.0	4.0	2.5	2.5	2.5	2.0	2.0	1.5	1.5
<b>m<sup>2</sup>/pallet</b>	160.0	120.0	100.0	75.0	75.0	60.0	60.0	45.0	45.0
<b>rolls/pallet</b>	40	30	40	30	30	30	30	30	30

\* all dimensions require minimum order quantities / other dimensions on request

\*\* Under a load of 1000 Pa



# TECH Wired Mat MT 5.1 Alu1/X/X-X

## Premium performance robust industry stone mineral wool wired mats for medium-high temperatures

TECH Wired Mat MT 5.1 is the premium thermal performance stone mineral wool mat stitched with galvanized wire on hexagonal galvanized wire mesh for flexible installation on uneven structures such as big diameter pipes, tanks and vessels, boilers, exhaust ducts and stacks with a maximum service temperature of up to 660 °C. TECH Wired Mat MT 5.1 is available in AS Quality (CL- ≤ 10 ppm) when in contact with austenitic steel structures. On request available also with stainless steel wire (X) or stainless steel wire and wire mesh (X-X) and reinforced aluminium facing (Alu1).



### Energy efficiency

Premium thermal insulation performance at medium to higher service temperatures up to 660 °C



### High service temperatures

Especially designed for high service temperatures up to 660 °C



### Sound insulation

The ability of mineral wool to act as a spring results in reducing vibration and noise emissions in industrial processes



### Nuclear plant quality

Certified for use in nuclear applications



### Fire reaction

Non-combustible, Euroclass A1 for effective fire protection on industry sites



### Environmental protection

Its Premium thermal performance allows to reduce significantly energy losses, the use of natural resources and CO<sub>2</sub> emissions



### Thermal Efficiency Indicator

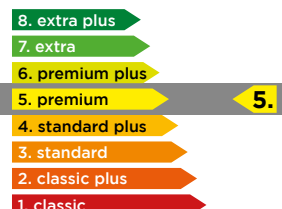



## Premium performance robust industry stone mineral wool wired mats

Characteristic	Symbol	Unit	Quantities and declared values								Standard
<b>Thermal behaviour Max. service temp.</b>	T	[°C]	660 (under 500 Pa)								EN 14706
			700								ASTM C411
<b>Thermal conductivity</b>	T	[°C]	50	100	200	300	400	500	600	650	EN 12667 ISO 13787
		[W/(m•K)]	0.039	0.045	0.061	0.081	0.106	0.137	0.175	0.197	
<b>Specific thermal capacity</b>	c	[kJ/(kg•K)]	1.03								ISO 10456
<b>Sound absorption*</b>	p	Hz	w	125	250	500	1,000	2,000	4,000	Thickness [mm]	EN ISO 11654 EN ISO 354
		-	1.00	0.41	0.97	1.03	1.03	1.05	1.10	50	
		-	1.00	0.76	0.90	0.99	1.06	1.08	1.11	100	
<b>Airflow resistivity*</b>	AFR	kPa-s/m	> 50								ISO 9053-1
<b>Fire protection / Behaviour in fire</b>	-	-	Non combustible; Euroclass A1								EN 13501-1
			Fire Spread Index = 0; Smoke Development Index < 20								ASTM E84
<b>Chemical behaviour</b>	-	-	AS Quality (CL10 according EN 13468 measurement) on request Do not contribute to corrosion of stainless steel No short term water absorption by partial immersion (WS1)								AGI Q 132 EN 13468 ASTM C795 EN 1609
<b>Application field</b>	-	-	Product for use in technical applications, such as big diameter pipes, tanks and vessels, boilers, exhaust ducts and stacks Certified for use in nuclear applications (PMUC 09-0011)								EN 14303 PMUC 09-0011
<b>Material</b>	-	-	Stone mineral wool, stitched on metallic mesh with either galvanized or austenitic stainless steel wire With quality marks EUCEB, unrisky regarding health according to regulation EC No 1272/2008 Note Q								CINI 2.2.02
<b>Facing</b>	-	-	On request: Reinforced aluminium facing (Alu1)								-
<b>Quality management</b>	-	-	CE-marked according to EN 14303 ISOVER is certified according to EN ISO 9001 and EN ISO 14001								EN 14303 EN ISO 9001 EN ISO 14001
<b>Miscellaneous</b>	-	-	MW-EN 14303-T2-ST(+)-660-WS1 [-CL10]								EN 14303
<b>Delivery form</b>	-	-	Please contact your local ISOVER dealer All dimensions require minimum order quantities Standard width: 500 mm, 600 mm, 1,000 mm Standard thickness range: 30 mm to 120 mm Other dimensions on request								-

\* These values proceed from tests conducted in laboratory under certain given conditions. Real life conditions may differ due to various ambient and operational factors. These values are therefore representative and should only be used as a guide for estimation purposes. ISOVER takes no responsibility in the case of not achieving the required acoustical performance.



# TECH Wired Mat MT 5.2 x/x-x

## Premium performance robust industry stone mineral wool wired mats for medium-high temperatures

TECH Wired Mat MT 5.2 is the premium thermal performance stone mineral wool mat stitched with galvanized wire on hexagonal galvanized wire mesh for flexible installation on uneven structures such as big diameter pipes, tanks and vessels, boilers, exhaust ducts and stacks with a maximum service temperature of up to 680 °C. TECH Wired Mat MT 5.2 is available on AS Quality (CL- ≤ 10 ppm) when in contact with austenitic steel structures. On request with stainless steel wire (X) or stainless steel wire and wire mesh (X-X).



### Energy efficiency

Premium thermal insulation performance at medium to higher service temperatures up to 680 °C



### High service temperatures

Especially designed for high service temperatures up to 680 °C



### Fire reaction

Non-combustible, Euroclass A1 for effective fire protection on industry sites



### Environmental protection

Its Premium thermal performance allows to reduce significantly energy losses, the use of natural resources and CO<sub>2</sub> emissions



### Thermal Efficiency Indicator

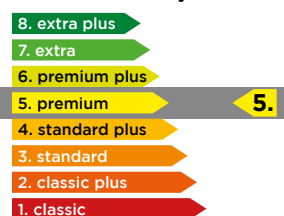



## Premium performance robust industry stone mineral wool wired mats for medium-high temperatures

Characteristic	Symbol	Unit	Quantities and declared values									Standard
Thermal behaviour	T	[°C]	680 (under 500 Pa)									EN 14706
			700									ASTM C411
Thermal conductivity	T	[°C]	50	100	150	200	300	400	500	600	650	EN 12667 ISO 13787
		[W/(m•K)]	0.041	0.047	0.054	0.063	0.082	0.107	0.135	0.171	0.192	
Specific thermal capacity	c	[kJ/(kg•K)]	1.03									ISO 10456
Fire protection / Behaviour in fire	-	-	Non combustible; Euroclass A1									EN 13501-1
			Fire Spread Index = 0; Smoke Development Index < 20									ASTM E84
Chemical behaviour	-	-	AS-Quality Do not contribute to corrosion of stainless steel No short term water absorption by partial immersion (WS1)									AGI Q 132 ASTM C795 EN 1609
Application field	-	-	Product for use in technical applications, such as big diameter pipes, tanks and vessels, boilers, exhaust ducts and stacks									EN 14303
Material	-	-	Stone mineral wool, stitched on metallic mesh with either galvanized or austenitic stainless steel wire With quality marks EUCEB, unrisky regarding health according to regulation EC No 1272/2008 Note Q									CINI 2.2.02
Quality management	-	-	CE-marked according to EN 14303 ISOVER is certified according to EN ISO 9001 and EN ISO 14001									EN 14303 EN ISO 9001 EN ISO 14001
Miscellaneous	-	-	MW-EN 14303-T2-ST(+)-680-WS1									EN 14303
Delivery form	-	-	Please contact your local ISOVER dealer All dimensions require minimum order quantities									-



# TECH Wired Mat MT 6.1 x/x-x

## Premium-Plus performance heavy-duty industry stone mineral wool wired mats for medium-high temperatures

TECH Wired Mat MT 6.1 is the premium-plus thermal performance stone mineral wool mat stitched with galvanized wire on hexagonal galvanized wire mesh for flexible installation on uneven high-temperature structures such as big diameter pipes, tanks and vessels, boilers, exhaust ducts and stacks with a maximum service temperature of up to 680 °C. TECH Wired Mat MT 6.1 is available in AS Quality (CL- ≤ 10 ppm) when in contact with austenitic steel structures and on request with stainless steel wire (X) or stainless steel wire and wire mesh (X-X).



### Energy efficiency

Premium-Plus thermal insulation performance at medium to higher service temperatures up to 680 °C



### High service temperatures

Especially designed for high service temperatures up to 680 °C



### Thin solution

Personal protection and heat loss requirements achieved with up to 35 % less insulation thickness than standard solutions



### Fire reaction

Non-combustible, Euroclass A1 for effective fire protection on industry sites



### Environmental protection

Its Premium-Plus thermal performance allows to reduce significantly energy losses, the use of natural resources and CO<sub>2</sub> emissions



### Thermal Efficiency Indicator

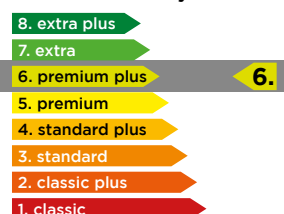



## Premium-Plus performance heavy-duty industry stone mineral wool wired mats

Characteristic	Symbol	Unit	Quantities and declared values								Standard	
<b>Thermal behaviour Max. service temp.</b>	T	[°C]	680 (under 500 Pa)								EN 14706	
			700								ASTM C411	
<b>Thermal conductivity</b>	T	[°C]	50	100	150	200	300	400	500	600	650	EN 12667 ISO 13787
		[W/(m•K)]	0.040	0.045	0.051	0.058	0.076	0.098	0.124	0.156	0.174	
<b>Specific thermal capacity</b>	c	[kJ/(kg•K)]	1.03								ISO 10456	
<b>Sound absorption*</b>	p	Hz	w	125	250	500	1,000	2,000	4,000	Thickness [mm]		EN ISO 11654 EN ISO 354
		-	0.95	0.19	0.87	0.86	0.93	0.98	1.09	50		
		-	1.00	0.73	0.80	0.90	0.98	1.05	1.13	100		
<b>Airflow resistivity*</b>	AFR	kPa-s/m	> 65								ISO 9053-1	
<b>Fire protection / Behaviour in fire</b>	-	-	Non combustible; Euroclass A1								EN 13501-1	
			Fire Spread Index = 0; Smoke Development Index < 20								ASTM E84	
<b>Chemical behaviour</b>	-	-	AS-Quality Do not contribute to corrosion of stainless steel No short term water absorption by partial immersion (WS1)								AGI Q 132 ASTM C795 EN 1609	
<b>Application field</b>	-	-	Product for use in technical applications, such as big diameter pipes, tanks and vessels, boilers, exhaust ducts and stacks								EN 14303	
<b>Material</b>	-	-	Stone mineral wool, stitched on metallic mesh with either galvanized or austenitic stainless steel wire With quality marks EUCEB, unrisky regarding health according to regulation EC No 1272/2008 Note Q								CINI 2.1.02	
<b>Facing</b>	-	-	-								-	
<b>Quality management</b>	-	-	CE-marked according to EN 14303 ISOVER is certified according to EN ISO 9001 and EN ISO 14001								EN 14303 EN ISO 9001 EN ISO 14001	
<b>Miscellaneous</b>	-	-	MW-EN 14303-T2-ST(+)-680-WS1								EN 14303	

\* These values proceed from tests conducted in laboratory under certain given conditions. Real life conditions may differ due to various ambient and operational factors. These values are therefore representative and should only be used as a guide for estimation purposes. ISOVER takes no responsibility in the case of not achieving the required acoustical performance.

Delivery form: Standard dimensions / packaging information*					
Thickness** d (mm)	Length l (mm)	Width b (mm)	m <sup>2</sup> /pack	m <sup>2</sup> /pallet	m <sup>2</sup> /truck
40	5,000	1,000	5.00	75.00	1,950
50	4,000	1,000	4.00	60.00	1,560
60	3,500	1,000	3.50	52.50	1,365
70	3,000	1,000	3.00	45.00	1,170

\* all dimensions require minimum order quantities / other dimensions on request

\*\* Under a load of 1000 Pa



# TECH Wired Mat HT 6.1

## Premium-Plus performance robust industry stone mineral wool wired mats for high temperatures

TECH Wired Mat HT 6.1 is the premium-plus thermal performance stone mineral wool mat stitched with galvanized wire on hexagonal galvanized wire mesh for flexible installation on uneven structures such as big diameter pipes, tanks and vessels, boilers, exhaust ducts and stacks with a maximum service temperature of up to 700 °C. TECH Wired Mat HT 6.1 is available on AS Quality (CL- ≤ 10 ppm).



### Energy efficiency

Premium-Plus thermal insulation performance at medium to higher service temperatures up to 700 °C



### High service temperatures

Especially designed for high service temperatures up to 700 °C



### Fire reaction

Non-combustible, Euroclass A1 for effective fire protection on industry sites



### Environmental protection

Its Premium-Plus thermal performance allows to reduce significantly energy losses, the use of natural resources and CO<sub>2</sub> emissions



### Nuclear Plant Quality

Certified for use in nuclear applications



### Thermal Efficiency Indicator

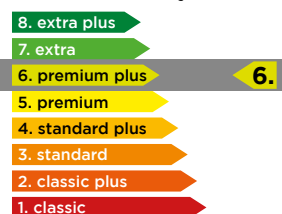

ISOVER-TDS-Industry-INT-ENG-TECH Wired Mat HT 6.1 2019-09





## Premium performance robust industry stone mineral wool wired mats for high temperatures

Characteristic	Symbol	Unit	Quantities and declared values								Standard
Thermal behaviour	T	[°C]	700 (under 500 Pa)								EN 14706
			700								ASTM C411
Thermal conductivity	T	[°C]	50	100	200	300	400	500	600	650	EN 12667 ISO 13787
		[W/(m•K)]	0.040	0.041	0.050	0.069	0.096	0.130	0.169	0.201	
Specific thermal capacity	c	[kJ/(kg•K)]	1.03								ISO 10456
Fire protection / Behaviour in fire	-	-	Non combustible; Euroclass A1								EN 13501-1
			Fire Spread Index = 0; Smoke Development Index < 20								ASTM E84
Chemical behaviour	-	-	AS-Quality Leachable chloride content less than 10 ppm (CL10) Do not contribute to corrosion of stainless steel No short term water absorption by partial immersion (WS1)								AGI Q 132 EN 13468 ASTM C795 EN 1609
Application field	-	-	Product for use in technical applications, such as big diameter pipes, tanks and vessels, boilers, exhaust ducts and stacks Certified for use in nuclear applications (PMUC 09-0015)								EN 14303 PMUC 09-0015
Material	-	-	Stone mineral wool, stitched on metallic mesh with either galvanized or austenitic stainless steel wire With quality marks EUCEB, unrisky regarding health according to regulation EC No 1272/2008 Note Q								CINI 2.2.02
Quality management	-	-	CE-marked according to EN 14303 ISOVER is certified according to EN ISO 9001 and EN ISO 14001								EN 14303 EN ISO 9001 EN ISO 14001
Miscellaneous	-	-	MW-EN 14303-T2-ST(+)-700-WS1								EN 14303
Delivery form	-	-	Please contact your local ISOVER dealer All dimensions require minimum order quantities								-



# U TECH Wired Mat MT 4.0 Alu1/V1/X/X-X

## The **ULTIMATE** solution for light and flexible wired mats in industry applications

ULTIMATE U TECH Wired Mat MT 4.0 is the light and flexible alternative to standard industry wired mats. With optimised product weight and high compression ratio at the same time, U TECH Wired Mat MT 4.0 makes transport, site logistics but also mounting and fixing easier and faster. When installed the product provides permanent standard-plus thermal performance even in tough environments at maximum service temperatures up to 560 °C. U TECH Wired Mat MT 4.0 is produced in AS Quality (CL- ≤ 10 ppm) for usage when in contact with austenitic steel structures. On request with stainless steel wire (X) or stainless steel wire and wire mesh (X-X) or yellow glass veil facing (V1) and reinforced aluminium facing (Alu1).



### Thermal insulation

Standard-Plus thermal performance for service temperatures up to 560 °C with up to 35 % better efficiency



### Cost effective solution

Standard-Plus thermal performance combined with lightweight provides installation time saving and less heat loss costs



### Fast installation

Flexibility, lightweight, compressibility and less cuttings for extended roll lengths helps to install the product easier and faster



### Easy handling

Unique lightness and packaging of ULTIMATE ensures an easy handling



### Fire reaction

Non-combustible, Euroclass A1 for effective fire protection on industry sites



### Improved logistics

Transport and storage savings with up to 80 % more material per pallet than standard solutions



### Thermal Efficiency Indicator

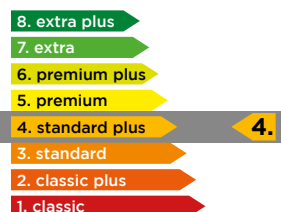



## The ULTIMATE solution for light and flexible wired mats in industry applications

Characteristic	Symbol	Unit	Quantities and declared values								Standard
<b>Thermal behaviour Max. service temp.</b>	T	[°C]	560 (under 250 Pa)								EN 14706
			650								ASTM C411
<b>Thermal conductivity</b>	T	[°C]	10	50	100	150	200	300	400	500	EN 12667 ISO 13787
		[W/(m•K)]	0.032	0.036	0.044	0.051	0.063	0.087	0.122	0.163	
<b>Specific thermal capacity</b>	c	[kJ/(kg•K)]	1.03								ISO 10456
<b>Sound absorption*</b>	p	Hz	w	125	250	500	1,000	2,000	4,000	Thickness [mm]	EN ISO 11654 EN ISO 354
		-	1.00	0.24	0.94	1.15	1.08	1.04	1.09	50	
		-	1.00	0.86	1.05	1.01	1.03	1.07	1.10	100	
<b>Airflow resistivity*</b>	AFR	kPa-s/m	> 30								ISO 9053-1
<b>Fire protection / Behaviour in fire</b>	-	-	Non combustible; Euroclass A1								EN 13501-1
			Fire Spread Index = 0; Smoke Development Index < 20								ASTM E84
<b>Chemical behaviour</b>	-	-	AS-Quality Leachable chloride content less than 10 ppm (CL10) Do not contribute to corrosion of stainless steel No short term water absorption by partial immersion (WS1)								AGI Q 132 EN 13468 ASTM C795 EN 1609
<b>Application field</b>	-	-	Product for use in technical applications, such as big diameter pipes, tanks and vessels, exhaust ducts and stacks or other equipments, with need for: thermal and/or acoustic insulation with high performances especially for light weight constructions								EN 14303
<b>Material</b>	-	-	ULTIMATE mineral wool, faced with a metallic wire mesh With quality marks EUCEB and RAL by the Gütegemeinschaft Mineralwolle e. V., unrisky regarding health according to German decree on dangerous substances, decree on prohibition of chemicals and to regulation EC N°1272/2008 Note Q								CINI 2.1.02
<b>Facing</b>	-	-	On request: Reinforced aluminium facing (Alu1) Yellow glass veil facing (V1)								-
<b>Quality management</b>	-	-	CE-marked according to EN 14303 Quality control according to VDI 2055 ISOVER is certified according to EN ISO 9001 and EN ISO 14001								EN 14303 VDI 2055 EN ISO 9001 EN ISO 14001
<b>Miscellaneous</b>	-	-	Insulating material identification number: 10.01.02.20.04 MW-EN 14303-T2-ST(+/250)560-WS1-CL10								AGI Q 132 EN 14303

\* These values proceed from tests conducted in laboratory under certain given conditions. Real life conditions may differ due to various ambient and operational factors. These values are therefore representative and should only be used as a guide for estimation purposes. ISOVER takes no responsibility in the case of not achieving the required acoustical performance.

Delivery form: Standard dimensions / packaging information*							
<b>Thickness** d [mm]</b>	30	40	50	60	80	100	120
<b>Width b [mm]</b>	600	600	600	600	600	600	600
<b>Length l [mm]</b>	11,000	9,500	7,500	6,300	4,700	4,000	3,300
<b>m<sup>2</sup>/pack</b>	13.20	11.40	9.00	7.56	5.64	4.80	3.96
<b>Slabs/pack</b>	18	18	18	18	18	18	18
<b>Packs/pallet</b>	238	205	162	136	102	86	71

\* all dimensions require minimum order quantities / other dimensions on request

\*\* Under a load of 1000 Pa



# U TECH Wired Mat MT 5.0 Alu1/V1/X/X-X

## The ULTIMATE solution for premium performance and light wired mats

ULTIMATE U TECH Wired Mat MT 5.0 is the efficient but still light alternative to higher-dense industry wired mats. With optimised product weight and high compression ratio at the same time U TECH Wired Mat MT 5.0 makes transport, site logistics but also mounting and fixing easier and faster. When installed the product provides permanent premium thermal performance even in tough environments at maximum service temperatures up to 540 °C. U TECH Wired Mat MT 5.0 is produced in AS Quality (CL- ≤ 10ppm) for usage when in contact with austenitic steel structures. On request with stainless steel wire (X) or stainless steel wire and wire mesh (X-X) or yellow glass veil facing (V1) and reinforced aluminium facing (Alu1).



### Energy efficiency

Premium thermal performance for service temperatures up to 540 °C with up to 35 % better efficiency



### Cost effective solution

Premium thermal performance combined with lightweight provides installation time saving and less heat loss costs



### Fast installation

Flexibility, lightweight, compressibility and less cuttings for extended roll lengths helps to install the product easier and faster



### Easy handling

Unique lightness and packaging of ULTIMATE ensures an easy handling



### Fire reaction

Non-combustible, Euroclass A1 for effective fire protection on industry sites



### Improved logistics

Transport and storage savings with up to 80 % more material per pallet than standard solutions



### Thermal Efficiency Indicator

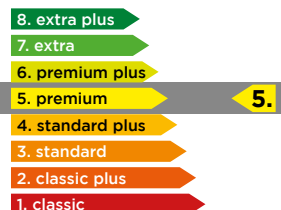



## The ULTIMATE solution for premium performance and light wired mats

Characteristic	Symbol	Unit	Quantities and declared values								Standard
<b>Thermal behaviour Max. service temp.</b>	T	[°C]	540 (under 500 Pa)								EN 14706
			700								ASTM C411
<b>Thermal conductivity</b>	T	[°C]	10	50	100	150	200	300	400	500	EN 12667
		[W/(m•K)]	0.031	0.036	0.041	0.049	0.057	0.078	0.104	0.138	ISO 13787
<b>Specific thermal capacity</b>	c	[kJ/(kg•K)]	1.03								ISO 10456
<b>Sound absorption*</b>	p	Hz	w	125	250	500	1,000	2,000	4,000	Thickness [mm]	EN ISO 11654 EN ISO 354
		-	1.00	0.35	1.01	1.07	1.02	1.06	1.09	50	
		-	1.00	0.88	1.00	0.97	1.04	1.05	1.08	100	
<b>Airflow resistivity*</b>	AFR	kPa-s/m	> 40								ISO 9053-1
<b>Fire protection / Behaviour in fire</b>	-	-	Non combustible; Euroclass A1								EN 13501-1
			Fire Spread Index = 0; Smoke Development Index < 20								ASTM E84
<b>Chemical behaviour</b>	-	-	AS-Quality Leachable chloride content less than 10 ppm (CL10) Do not contribute to corrosion of stainless steel No short term water absorption by partial immersion (WS1)								AGI Q 132 EN 13468 ASTM C795 EN 1609
<b>Application field</b>	-	-	Product for use in technical applications, such as big diameter pipes, tanks and vessels, exhaust ducts and stacks or other equipments, with need for: thermal and/or acoustic insulation with high performances especially for light weight constructions								EN 14303
<b>Material</b>	-	-	ULTIMATE mineral wool, faced with a metallic wire mesh and stainless steel steeching wire With quality marks EUCEB and RAL by the Gütegemeinschaft Mineralwolle e. V., unrisky regarding health according to German decree on dangerous substances, decree on prohibition of chemicals and to regulation EC No 1272/2008 Note Q								CINI 2.1.02
<b>Facing</b>	-	-	On request: Reinforced aluminium facing (Alu1) Yellow glass veil facing (V1)								-
<b>Quality management</b>	-	-	CE-marked according to EN 14303 Quality control according to VDI 2055 ISOVER is certified according to EN ISO 9001 and EN ISO 14001								EN 14303 VDI 2055 EN ISO 9001 EN ISO 14001
<b>Miscellaneous</b>	-	-	Insulating material identification number: 10.01.02.40.05 MW-EN-14303-T2-ST(+)-540-WS1-CL10								AGI Q 132 EN 14303

\* These values proceed from tests conducted in laboratory under certain given conditions. Real life conditions may differ due to various ambient and operational factors. These values are therefore representative and should only be used as a guide for estimation purposes. ISOVER takes no responsibility in the case of not achieving the required acoustical performance.

Delivery form: Standard dimensions / packaging information*								
<b>Thickness** d [mm]</b>	30	40	50	60	70	80	100	120
<b>Width b [mm]</b>	600	600	600	600	600	600	600	600
<b>Length l [mm]</b>	10,500	7,900	6,300	5,200	4,500	3,900	3,100	2,600
<b>m<sup>2</sup>/pack</b>	12.60	9.48	7.56	6.24	5.40	4.68	3.72	3.12
<b>m<sup>2</sup>/pallet</b>	226.80	170.64	136.08	112.32	97.20	84.24	66.96	56.16
<b>Rolls/pack</b>	2	2	2	2	2	2	2	2
<b>Packs/pallet</b>	18	18	18	18	18	18	18	18

\* all dimensions require minimum order quantities / other dimensions on request

\*\* Under a load of 1000 Pa



# U TECH Wired Mat MT 6.0 Alu1/V1/X/X-X

## The **ULTIMATE** solution for premium-plus performance and efficient industry wired mats in medium-high temperatures

ULTIMATE U TECH Wired Mat MT 6.0 is the efficient and sustainable alternative to heavy-dense industry wired mats. Designed for premium-plus thermal insulation at temperatures of up to 620 °C, continuously and even under tough conditions e.g. mechanical stress like vibrations, U Tech Wired Mat MT 6.0 provides the best combination between thermal efficiency, flexibility and light weight. U TECH Wired Mat MT 6.0 is produced in AS Quality (CL- ≤ 10 ppm) for usage when in contact with austenitic steel structures. On request with stainless steel wire (X) or stainless steel wire and wire mesh (X-X) or yellow glass veil facing (V1) and reinforced aluminium facing (Alu1).



### Energy efficiency

Premium-Plus thermal performance for service temperatures up to 620 °C with up to 35 % better efficiency



### High service temperatures

Especially designed for high service temperatures up to 620 °C



### Thin solution

Personal protection and heat loss requirements achieved with up to 35 % less insulation thickness than standard solutions



### Fast installation

Flexibility, lightweight, compressibility and less cuttings for extended roll lengths helps to install the product easier and faster



### Fire reaction

Non-combustible, Euroclass A1 for effective fire protection on industry sites



### Easy handling

Unique lightness and packaging of ULTIMATE ensures an easy handling



### Thermal Efficiency Indicator

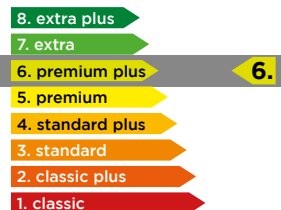



## The ULTIMATE solution for premium-plus performance wired mats

Characteristic	Symbol	Unit	Quantities and declared values									Standard
Thermal behaviour Max. service temp.	T	[°C]	620 (under 500 Pa)									EN 14706
			700									ASTM C411
Thermal conductivity	T	[°C]	10	50	100	150	200	300	400	500	600	EN 12667 ISO 13787
		[W/(m•K)]	0.031	0.035	0.040	0.047	0.054	0.072	0.096	0.120	0.162	
Specific thermal capacity	c	[kJ/(kg•K)]	1.03									ISO 10456
Sound absorption*	p	Hz	w	125	250	500	1,000	2,000	4,000	Thickness [mm]		EN ISO 11654 EN ISO 354
		-	1.00	0.44	1.11	1.01	1.01	1.05	1.09	50		
		-	1.00	0.87	0.91	0.99	1.03	1.02	1.08	100		
Airflow resistivity*	AFR	kPa-s/m	> 50									ISO 9053-1
Fire protection / Behaviour in fire	-	-	Non combustible; Euroclass A1									EN 13501-1
			Fire Spread Index = 0; Smoke Development Index < 20									ASTM E84
Chemical behaviour	-	-	AS-Quality Leachable chloride content less than 10 ppm (CL10) Do not contribute to corrosion of stainless steel No short term water absorption by partial immersion (WS1)									AGI Q 132 EN 13468 ASTM C795 EN 1609
Application field	-	-	Product for use in technical applications, such as big diameter pipes, tanks and vessels, exhaust ducts and stacks or other equipments, with need for: thermal and/or acoustic insulation with high performances especially for improved energy efficient constructions									EN 14303
Material	-	-	ULTIMATE mineral wool, faced with a metallic wire mesh and stainless steel steeching wire With quality marks EUCEB and RAL by the Gütegemeinschaft Mineralwolle e. V., unrisky regarding health according to German decree on dangerous substances, decree on prohibition of chemicals and to regulation EC No 1272/2008 Note Q									CINI 2.1.02
Facing	-	-	On request: Reinforced aluminium facing (Alu1) Yellow glass veil facing (V1)									-
Quality management	-	-	CE-marked according to EN 14303 Quality control according to VDI 2055 ISOVER is certified according to EN ISO 9001 and EN ISO 14001									EN 14303 VDI 2055 EN ISO 9001 EN ISO 14001
Miscellaneous	-	-	Insulating material identification number: 10.01.03.50.07 MW-EN-14303-T2-ST(+)-620-WS1-CL10									AGI Q 132 EN 14303

\* These values proceed from tests conducted in laboratory under certain given conditions. Real life conditions may differ due to various ambient and operational factors. These values are therefore representative and should only be used as a guide for estimation purposes. ISOVER takes no responsibility in the case of not achieving the required acoustical performance.

Delivery form: Standard dimensions / packaging information*									
Thickness** d [mm]	30	40	50	60	70	80	90	100	120
Width b [mm]	600	600	600	600	600	600	600	600	600
Length l [mm]	11,000	7,500	6,000	5,000	4,300	3,700	3,300	3,000	2,500
m <sup>2</sup> /pack	12.00	9.00	7.20	6.00	5.16	4.44	3.96	3.60	3.00
m <sup>2</sup> /pallet	120.000	67.500	43.200	30.000	22.188	16.428	13.068	10.800	7.500
Rolls/pack	2	2	2	2	2	2	2	2	2
Packs/pallet	18	18	18	18	18	18	18	18	18

\* all dimensions require minimum order quantities / other dimensions on request

\*\* Under a load of 1000 Pa

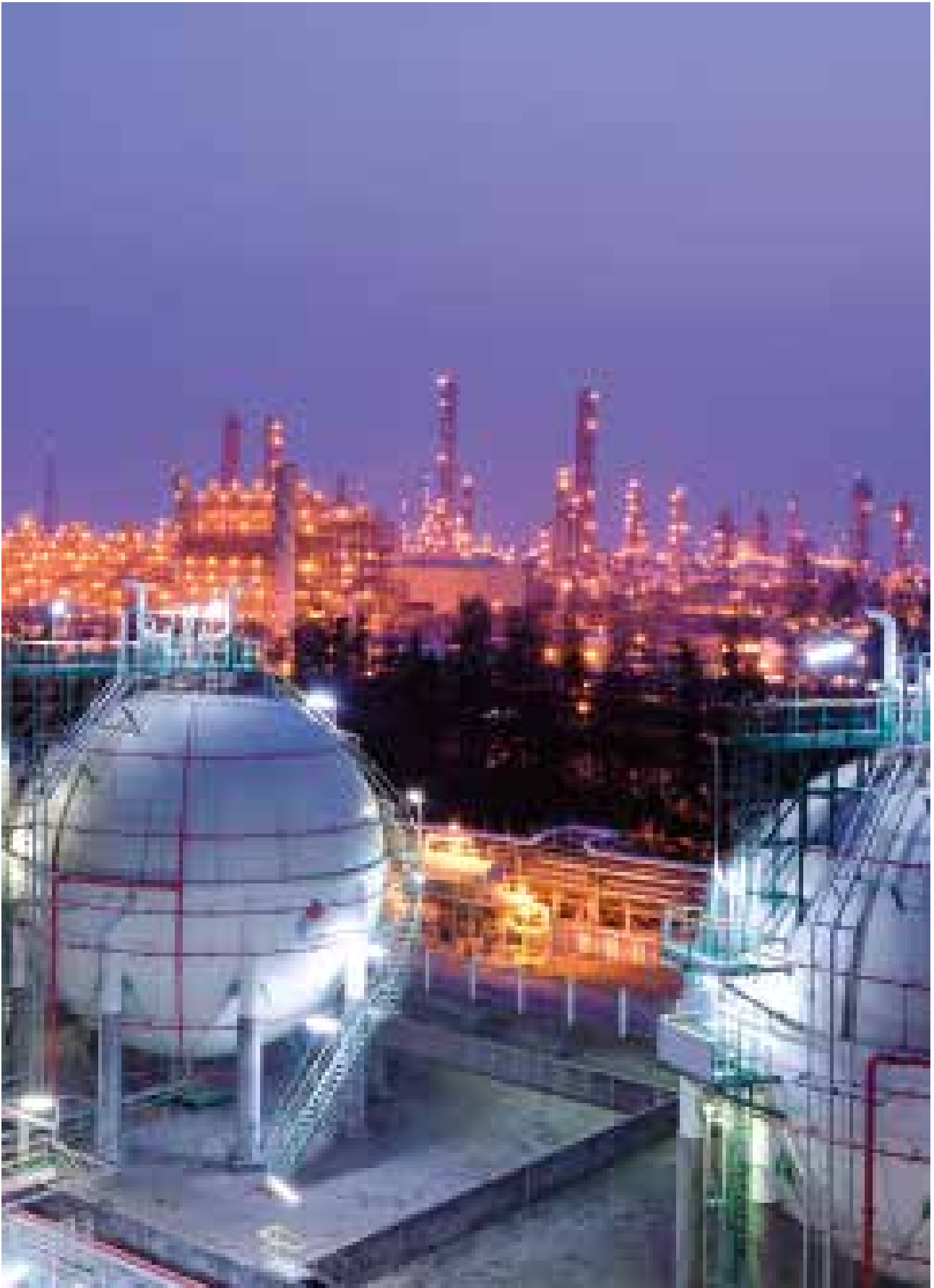

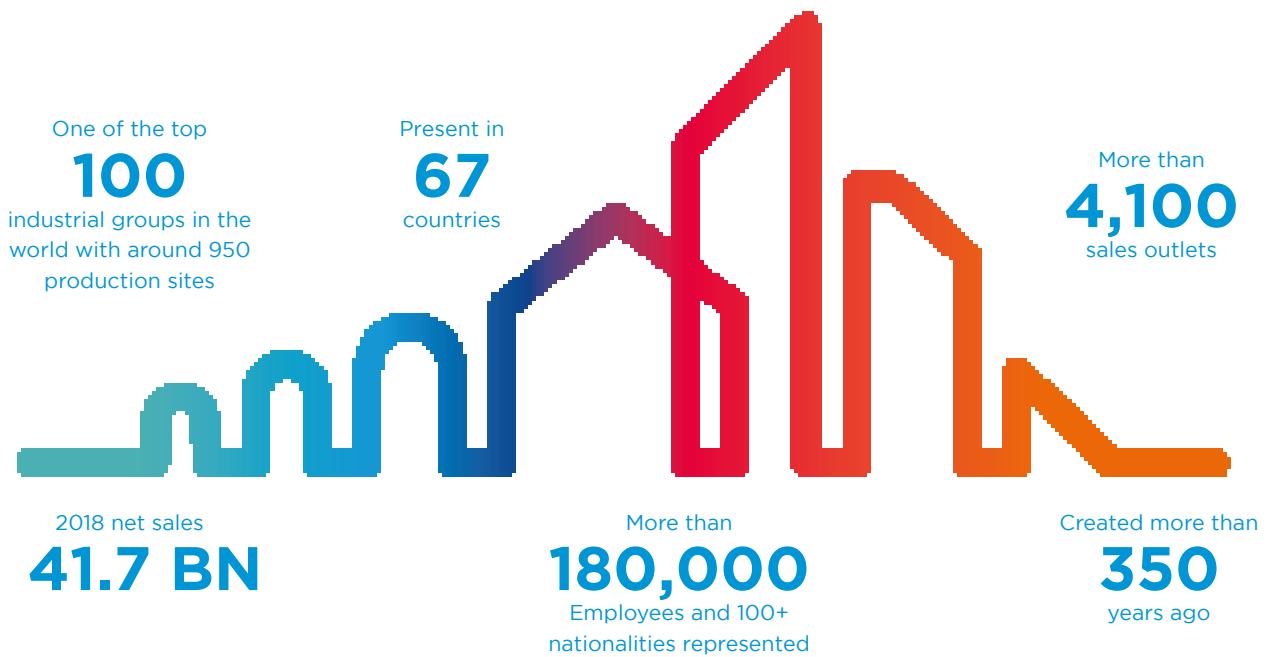







**Saint-Gobain ISOVER**

Tour Saint-Gobain

12 place de l'Iris

92096 La Défense Cedex - France

[www.isover-technical-insulation.com](http://www.isover-technical-insulation.com)

The information given in this brochure is based on our current knowledge and experience. If any information is incorrect this is not deliberate or grossly negligent. This document is not continually updated and we cannot be held responsible for any unintentional errors. For the most up-to-date information, please visit our website: [www.isover-technical-insulation.com](http://www.isover-technical-insulation.com)