

EC-TYPE EXAMINATION CERTIFICATE (MODULE B)

Certificate No:
MEDB00006FV
Revision No:
1

Application of: Directive 2014/90/EU of 23 July 2014 on marine equipment (MED). This Certificate is issued by DNV GL SE based on the notification of the Federal Maritime and Hydrographic Agency of Germany.

This is to certify:

That the "A" Class divisions, fire integrity

with type designation(s)
Steel Deck A-30

Issued to

SAINT-GOBAIN ISOVER G+H AG
Ludwigshafen am Rhein, Rheinland-Pfalz, Germany

is found to comply with the requirements in the following Regulations/Standards:

Regulation **(EU) 2019/1397,**

item No. MED/3.11a. SOLAS 74 as amended, Regulation II-2/3.2 & II-2/9, IMO 2010 FTP Code, IMO MSC/Circ.1120 and IMO MSC.1/Circ.1434, IMO MSC.1/Circ.1435.

Further details of the equipment and conditions for certification are given overleaf.

This Certificate is valid until **2025-02-19**.

Issued at **Hamburg** on **2020-06-25**

DNV GL local station:
Augsburg

Approval Engineer:
Timo Linn

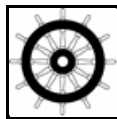

Notified Body
No.: **0098**

for **DNV GL SE**

Gerhard Aulbert
Head of Notified Body

A U.S. Coast Guard approval number will be assigned to the equipment when the production module has been completed and will appear on the production module certificate (module D, E or F), as allowed by the "Agreement between the European Community and the United States of America on Mutual Recognition of Certificates of Conformity for Marine Equipment", signed February 27th, 2004, and amended by Decision No 1/2018 dated February 18th, 2019.

The mark of conformity may only be affixed to the above type approved equipment and a Manufacturer's Declaration of Conformity issued when the production-surveillance module (D, E or F) of Annex B of the MED is fully complied with and controlled by a written inspection agreement with a Notified Body. The product liability rests with the manufacturer or his representative in accordance with Directive 2014/90/EU. This certificate is valid for equipment, which is conform to the approved type. The manufacturer shall inform DNV GL SE of any changes to the approved equipment. This certificate remains valid unless suspended, withdrawn, recalled or cancelled. Should the specified regulations or standards be amended during the validity of this certificate, the product is to be re-approved before being placed on board a vessel to which the amended regulations or standards apply.

LEGAL DISCLAIMER: Unless otherwise stated in the applicable contract with the holder of this document, or following from mandatory law, the liability of DNV GL AS, its parent companies and subsidiaries as well as their officers, directors and employees ("DNV GL") arising from or in connection with the services rendered for the purpose of the issuance of this document or reliance thereon, whether in contract or in tort (including negligence), shall be limited to direct losses and under any circumstance be limited to 300,000 USD.



Job Id: **344.1-004262-22**
Certificate No: **MEDB00006FV**
Revision No: **1**

Product description

"Steel Deck A-30"

Steel bulkheads with different insulation construction are listed in enclosed appendix A.

Application/Limitation

Approved for use as horizontal fire retarding division of class A-30. Applications/Limitations see Appendix.

The insulation materials and adhesives used have to be approved according to the Marine Equipment Directive and bear the Mark of Conformity. This requirement may also be applicable for surface materials used, if required by relevant rules and regulations.

Each product is to be supplied with its manual for installation and maintenance.

Type Examination documentation

Test report no. PGA10230 dated 7 May 2013 (U SeaProtect 76/25 + 76/20) and no. PGA10289 dated 6 August 2013 (U SeaProtect 24/50 + 66/25) both from Danish Institute of Fire and Security Technology (DBI), Hvidovre, Denmark.

Assessment report nos.:

PHA10498a (insulation change from slabs to rolls) dated 15 January 2020,
PHA10498c (minimum thickness and density) dated 16 December 2019,
PHA10498b (alternative insulation on stiffeners) dated 09 December 2019,
PHA10498d (position of joints) dated 27 March 2020
PHA10498e (mounting methods for insulation on stiffeners) dated 21 June 2016,
PHA10498f (washer diameter) dated 16 December 2020.
PHA10498g (pin pattern) dated 15 January 2020.
All from Danish Institute of Fire and Security Technology (DBI), Hvidovre, Denmark.

Drawing no. AK2307 (4 pages) dated 11 December 2014 from SAINT-GOBAIN ISOVER G+H AG.

Certificate has been renewed based on the MED B certificate MED-B-9328.

Tests carried out

Tested according to IMO Resolution MSC.307(88) – 2010 FTP Code Annex 1, Part 3

Marking of product

The product or packing is to be marked with name and address of manufacturer, type designation, MED Mark of Conformity (see page 1) and USCG approval number, if applicable.

USCG Approval Category (Module B) number

This product has been assigned a U.S. Coast Guard Module B number 164.105/EC0098 to note type approval to Module B only as it pertains to obtaining US Coast Guard approval as allowed by the "Agreement between the European Community and the United States of America on Mutual Recognition of Certificates of Conformity for Marine Equipment" signed February 27th, 2004 and amended by Decision No.1/2018 dated February 18th, 2019.

Job Id: **344.1-004262-22**
 Certificate No: **MEDB00006FV**
 Revision No: **1**

Appendix A Rev. No. 0 to MEDB00006FV
Alternative constructions:

	Product Description	Application / Limitations	Type Approval Documentation
1	<p>"U SeaProtect 24/50 + 66/25" Composed of a stiffened steel deck insulated underneath with 50 mm mineral wool of type U SeaProtect 24 (density 24 kg/m³) from SAINT-GOBAIN ISOVER G+H AG. 25 mm mineral wool of type U SeaProtect 66 (density 66 kg/m³) from SAINT-GOBAIN ISOVER G+H AG is fitted around the stiffeners. Insulation (U SeaProtect 66) is fitted inside the void of the stiffeners.</p> <p>The insulation is fasten with 3 mm steel pins and 38 mm steel washers. Distance between pins is maximum 300 mm.</p> <p>See drawing in appendix B for further details.</p>	<p>Approved for use as horizontal fire retarding division of class A-30.</p> <p>The insulation thickness may be increased up to a maximum area weight of 5280 g/m². Insulation density may be increased up to 66 kg/m³ or a maximum area weight of 5280 g/m² (whichever comes first).</p>	<p>Test report no. PGA10289</p> <p>Assessment report nos. PHA10498c (minimum thickness and density), PHA10498b (alternative insulation on stiffeners), PHA10498d (position of joints), PHA10498e (mounting methods for insulation on stiffeners, PHA10498f (washer diameter) dated 16 December 2020, PHA10498g (pin pattern).</p> <p>Drawing no. AK2307</p>
2	<p>"U SeaProtect 24/50 + 24/50" Composed of a stiffened steel deck insulated underneath with 50 mm mineral wool of type U SeaProtect 24 (density 24 kg/m³) from SAINT-GOBAIN ISOVER G+H AG. 50 mm mineral wool of type U SeaProtect 24 (density 24 kg/m³) from SAINT-GOBAIN ISOVER G+H AG is fitted around the stiffeners. Insulation (U SeaProtect) is fitted inside the void of the stiffeners.</p> <p>The insulation is fasten with 3 mm steel pins and 38 mm steel washers. Distance between pins is maximum 300 mm.</p> <p>See drawing in appendix B for further details.</p>	<p>Approved for use as horizontal fire retarding division of class A-30.</p> <p>The insulation thickness may be increased up to a maximum area weight of 5280 g/m². Insulation density may be increased up to 66 kg/m³ or a maximum area weight of 5280 g/m² (whichever comes first).</p>	<p>Test report no. PGA10289</p> <p>Assessment report nos. PHA10498c (minimum thickness and density), PHA10498b (alternative insulation on stiffeners), PHA10498d (position of joints), PHA10498e (mounting methods for insulation on stiffeners, PHA10498f (washer diameter) dated 16 December 2020. PHA10498g (pin pattern).</p> <p>Drawing no. AK2307</p>
3	<p>"U SeaProtect 24/50 + 76/20" Composed of a stiffened steel deck insulated underneath with 50 mm mineral wool of type U SeaProtect 24 (density 24 kg/m³) from SAINT-GOBAIN ISOVER G+H AG. 20 mm mineral wool of type U SeaProtect 76 (density 76 kg/m³) from SAINT-GOBAIN ISOVER G+H AG is fitted around the stiffeners. Insulation (U SeaProtect 76) is fitted inside the void of the stiffeners.</p> <p>The insulation is fasten with 3 mm steel pins and 38 mm steel washers. Distance between pins is maximum 300 mm.</p> <p>See drawing in appendix B for further</p>	<p>Approved for use as horizontal fire retarding division of class A-30.</p> <p>The insulation thickness may be increased up to a maximum area weight of 5280 g/m². Insulation density may be increased up to 66 kg/m³ or a maximum area weight of 5280 g/m² (whichever comes first).</p>	<p>Test report no. PGA10289</p> <p>Assessment report nos. PHA10498c (minimum thickness and density), PHA10498b (alternative insulation on stiffeners), PHA10498d (position of joints), PHA10498e (mounting methods for insulation on stiffeners), PHA10498f (washer diameter) dated 16 December 2020. PHA10498g (pin pattern).</p>

Job Id: **344.1-004262-22**
 Certificate No: **MEDB00006FV**
 Revision No: **1**

	details.		Drawing no. AK2307
4	<p>"U SeaProtect 24/50 + 56/30" Composed of a stiffened steel deck insulated underneath with 50 mm mineral wool of type U SeaProtect 24 (density 24 kg/m³) from SAINT-GOBAIN ISOVER G+H AG. 30 mm mineral wool of type U SeaProtect 56 (density 56 kg/m³) from SAINT-GOBAIN ISOVER G+H AG is fitted around the stiffeners. Insulation (U SeaProtect 56) is fitted inside the void of the stiffeners.</p> <p>The insulation is fasten with 3 mm steel pins and 38 mm steel washers. Distance between pins is maximum 300 mm.</p> <p>See drawing in appendix B for further details.</p>	<p>Approved for use as horizontal fire retarding division of class A-30.</p> <p>The insulation thickness may be increased up to a maximum area weight of 5280 g/m². Insulation density may be increased up to 66 kg/m³ or a maximum area weight of 5280 g/m² (whichever comes first).</p>	<p>Test report no. PGA10289</p> <p>Assessment report nos. PHA10498c (minimum thickness and density), PHA10498b (alternative insulation on stiffeners), PHA10498d (position of joints), PHA10498e (mounting methods for insulation on stiffeners), PHA10498f (washer diameter) dated 16 December 2020. PHA10498g (pin pattern).</p> <p>Drawing no. AK2307</p>
5	<p>"U SeaProtect 76/25 + 76/20" Composed of a stiffened steel deck insulated underneath with 25 mm mineral wool of type U SeaProtect 76 (density 76 kg/m³) from SAINT-GOBAIN ISOVER G+H AG. 20 mm U SeaProtect 76 is fitted around the stiffeners. Insulation (U SeaProtect 76) is fitted inside the void of the stiffeners.</p> <p>The insulation is fasten with 3 mm steel pins and 38 mm steel washers. Distance between pins is maximum 300 mm.</p> <p>See drawing in appendix B for further details..</p>	<p>Approved for use as horizontal fire retarding division of class A-30.</p> <p>The insulation thickness may be increased up to a maximum area weight of 5280 g/m². Insulation density may be increased up to 66 kg/m³ or a maximum area weight of 5280 g/m² (whichever comes first).</p>	<p>Test report no. PGA10230</p> <p>Assessment report nos. PHA10498c (minimum thickness and density), PHA10498b (alternative insulation on stiffeners), PHA10498d (position of joints), PHA10498e (mounting methods for insulation on stiffeners), PHA10498f (washer diameter) dated 16 December 2020. PHA10498g (pin pattern).</p> <p>Drawing no. AK2307</p>

Job Id: **344.1-004262-22**
 Certificate No: **MEDB00006FV**
 Revision No: **1**

Appendix B Rev. No. 0 to MEDB00006FV

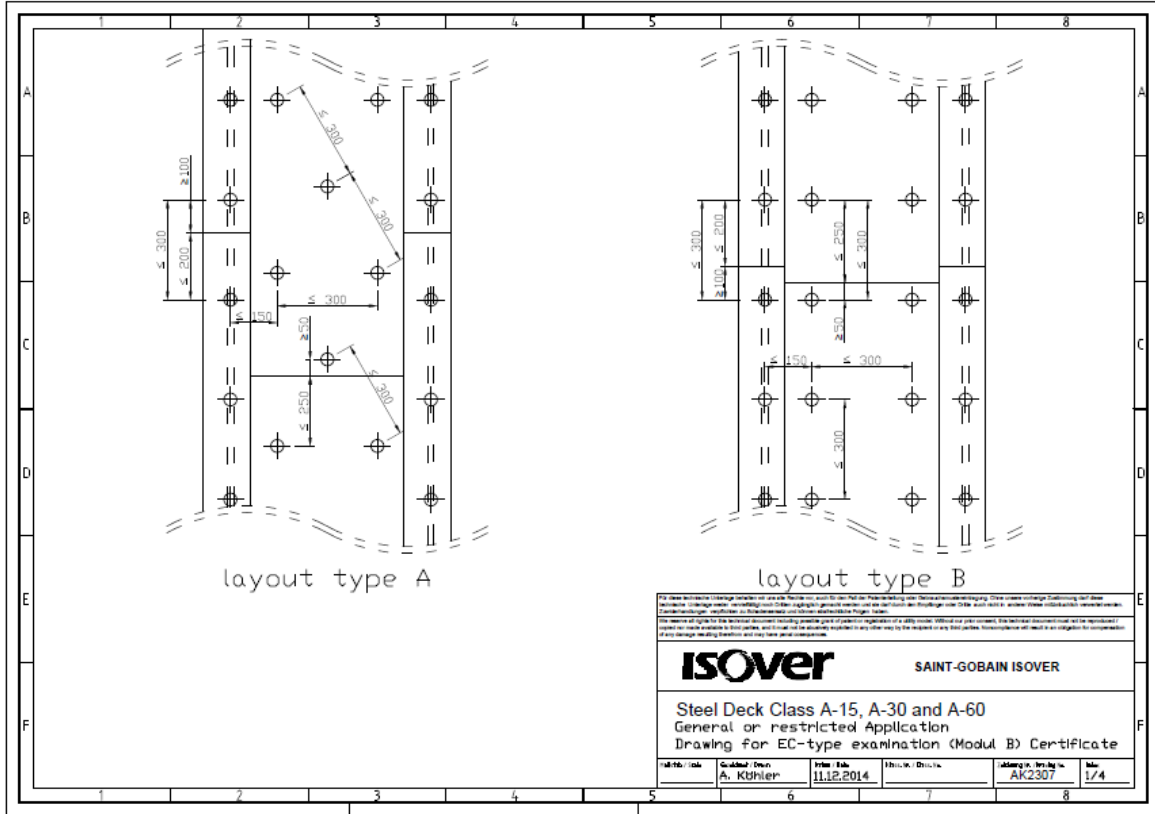

Job Id: **344.1-004262-22**
 Certificate No: **MEDB00006FV**
 Revision No: **1**

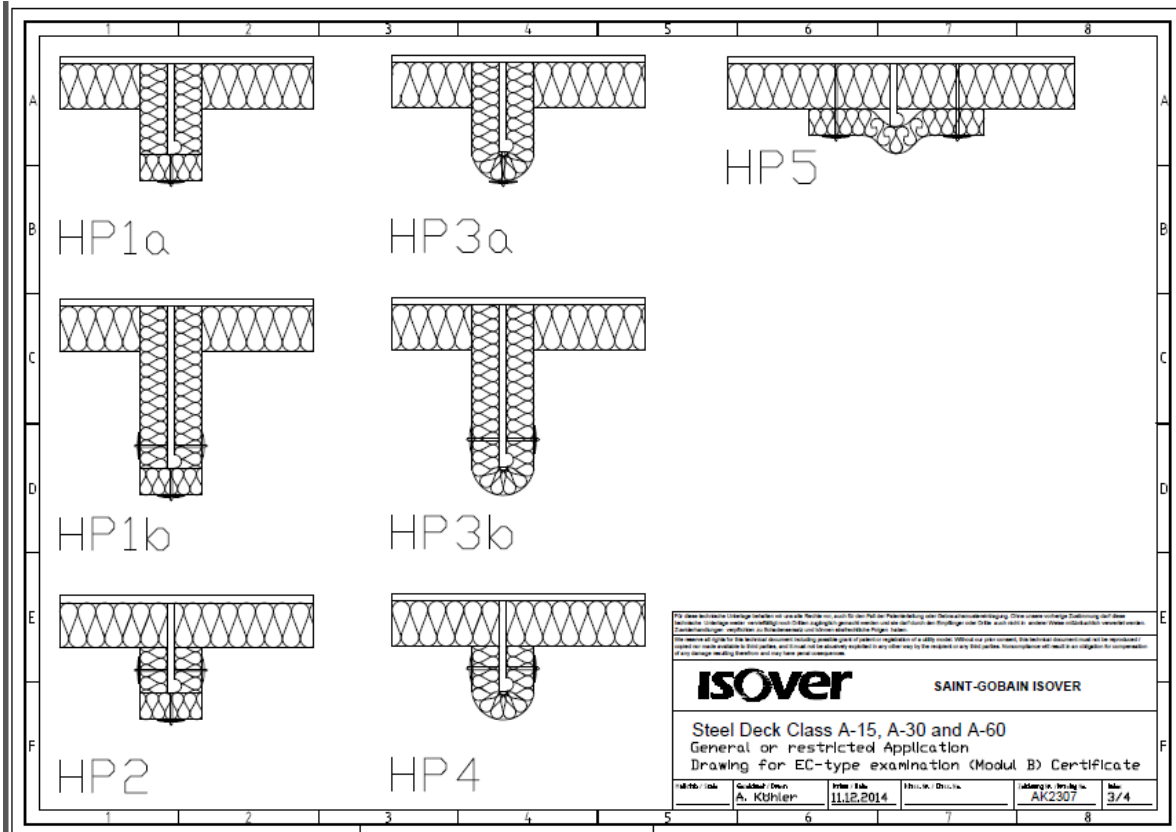
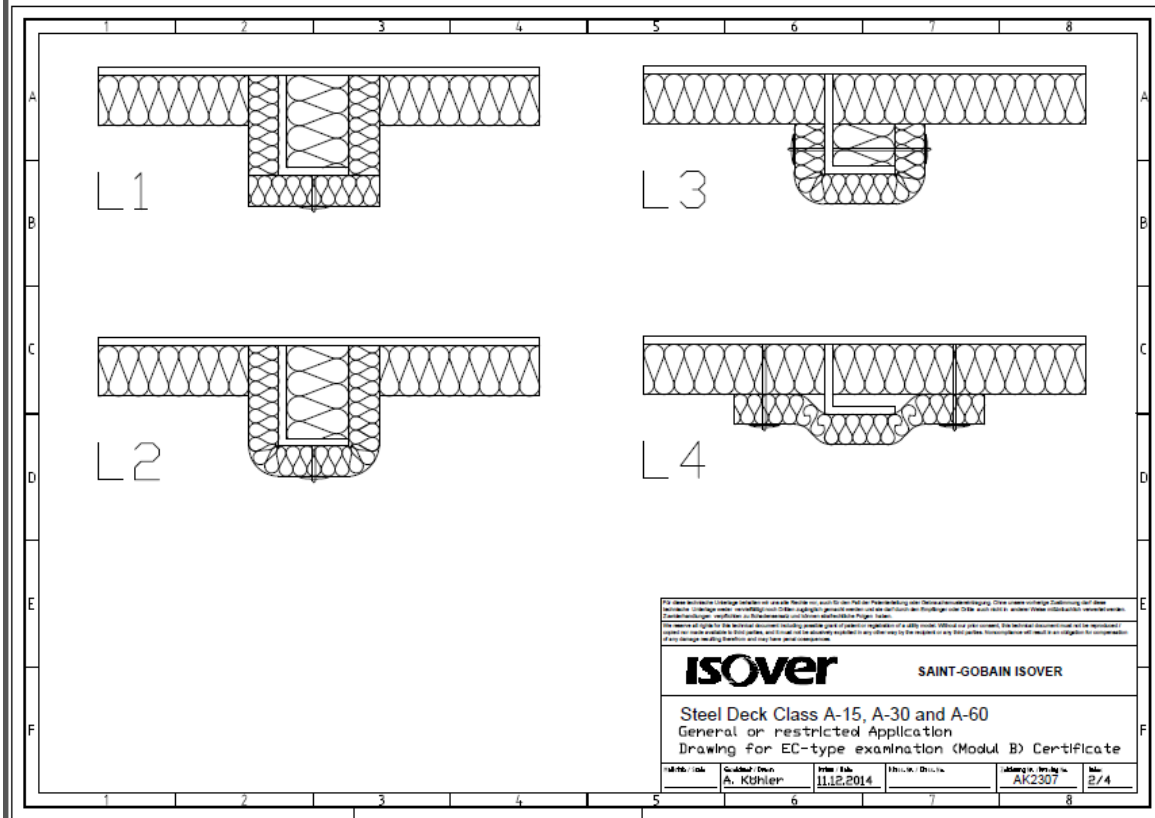

Job Id: **344.1-004262-22**
 Certificate No: **MEDB00006FV**
 Revision No: **1**

